

序号	零件号	说明	数量	材质	备注
1	8000238	40mm R tall yellow lid	2	Sub-asm	
2	180335	M6-18 set Screw	2	Std	
3	180336	M6 shoulder bolt 8x4.5	6	std part	
4	180179	M6-12 BHSCS	6	std	
5	180180	M6 flat washer	6	std	
6	180328	M5x9 FHSCS screw	8	304 ss	
7	300422	side plate	2	T6061-T6	
8	320349	link-plate	4	304 ss	
9	300423	link post	3	T6061-T6	
10	180132	Handle with M6 therad	2	STD part	
11	180348	M6 Flat Washer 18-8	2	std	
12	600151	plastic bushings for 90 degree angle 400 800454	2	PTFE	

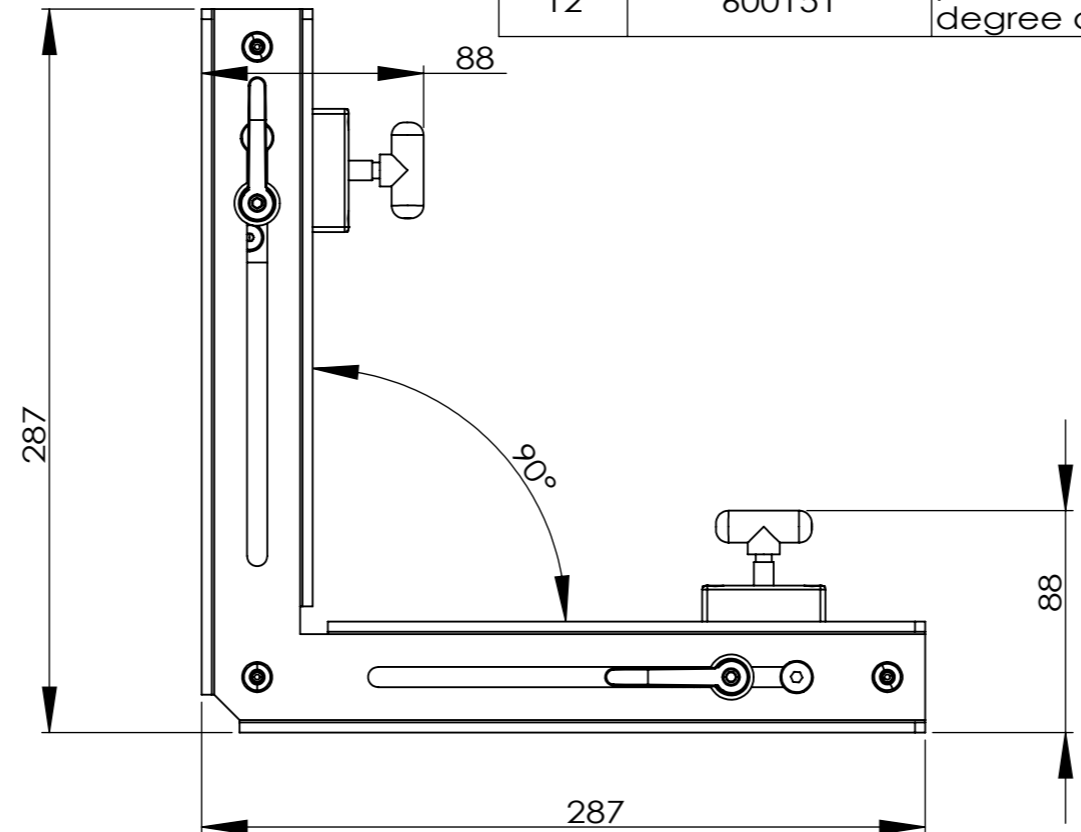

NOTES: UNLESS OTHERWISE SPECIFIED

1. INSPECT \boxed{ST} DIMENSIONS PER ISO 2768-M
2. 1° DRAFT ALLOWED FOR CASTING
3. REMOVE ALL BURRS AND BREAK SHARP EDGES.
4. IF CAST, TUMBLE DEBUR AFTER CASTING
5. FOR GENERAL DIMENSIONS NOT SPECIFIED SEE 3D CAD DATA
6. SURFACE ROUGHNESS

THIS DOCUMENT, AND THE INFORMATION IT CONTAINS, INCLUDING THE PRINCIPLES OF DESIGN, IS THE EXCLUSIVE PROPERTY OF MAGSWITCH TECHNOLOGY WORLDWIDE AND IS CONFIDENTIAL. ACCORDINGLY, THIS INFORMATION IS SUBMITTED TO YOU WITH THE AGREEMENT THAT IT IS NOT TO BE REPRODUCED, COPIED, OR LOANED IN PART OR IN WHOLE, NOR IS THE INFORMATION TO BE RELAYED TO ANY OTHER INDIVIDUAL OR COMPANY EXCEPT AS MTW FIRST AUTHORIZES IN WRITING. ACCEPTANCE OF THIS DOCUMENT CONSTITUTES AGREEMENT TO THESE RESTRICTIONS.

INTERPRET DRAWING PER: ISO 2768-M	DRAWN Frank	DATE 2012/3/8
DIMENSIONS ARE IN MILLIMETERS	DESIGN	DATE
 THIRD ANGLE PROJECTION	STD. CHECK	DATE
	F/F CHECK	DATE
	APPROVED	DATE
DO NOT SCALE		

8774 YATES DRIVE, SUITE 140
WESTMINSTER, COLORADO 80031
303-468-0662 / FAX 303-951-9918

TITLE:
40 mm full 90 degree angle 400

SIZE B	CAGE CODE	DWG. NO. 8000454	REV 3
SCALE 2:5		WEIGHT: g	SHEET 1 OF 1