



SINCE 1990

# HWANG CHERNG BIN

Specialty Tools Inc.

## SPECIAL TOOLS FOR TRUCK

卡車特殊修護工具



H.C.B-C1410



H.C.B-B1402



H.C.B-A1663



H.C.B-A1608

H.C.B-A1614

H.C.B is the only truck repair tool R&D company in Taiwan and gets government subsidies for designing new tools.

# COMPANY PROFILE

Founded in 1990, HWANG CHERNG BIN (H.C.B) Specialty Tools Inc. plays an innovative role in special automotive, truck tools and equipments. We developed tools for many car and truck manufacturers such as Mercedes-Benz, BMW, Scania, Volvo, Hino, Fuso, Volkswagen, Audi, Honda....., etc. Our tool range is wide. It covers engine, transmission, panel, and wheel, especially chassis.

The factory of H.C.B occupies around 4 thousand square meters. This spacious factory has various facilities, including testing lab, R&D lab, sample room, training room, and employee break room which can help staff increase their working efficiency effectively.

In Taiwan, HCB, one of the world's leading manufacturers. We used to be a specialist in automotive tools. Now we're not only a specialist in automotive tools, but also in truck tools. We are the only truck tools R&D Company in Taiwan which accesses governmental allowance for designing new products.

When looking for optimal and professional vehicle repair tools, the first choice throughout the world is always H.C.B tools.

The primary goal of H.C.B is to make vehicle repair safer, easier, and faster. Furthermore, make it more economical.

In order to keep up with market trend, H.C.B has a professional R&D team which has developed over 7 hundred kinds of tools. Besides, for now H.C.B has more than 80 patents in Taiwan, Germany, U.S.A, and Japan. More importantly, our quality earns ISO 9001/CE/TUV approval to ensure our product's great quality.





# Company History

25 years of quality insisting and R&D

## 1990~1999

- 創始社長(董事長 黃盛彬 先生)(1990.5.1) 台灣嘉義創立 創業者 黃盛彬 會長に 就任 (1990.5.1)
- 開始代工多國品牌汽機工具 Started out doing OEM works for many countries.
- 自動車用修理工具の改良 ニーズの対応OEM・海外代理店開会中を始める。
- 開發第一組 BENZ 底盤修理工具(H.C.B-A1001) USA, PAT. (1998.7.20) , 迄 約有80多項專利(含歐、美、日)
- Develop first BENZ repair tool(H.C.B-A1001) USA, PAT (1998.7.20), and awarded 80 patents from Germany, America, Japan and Taiwan.
- ベントリヤー・修整ツールの開発に世界で初めて成功し、80項目の特許を取得しました。
- 以H.C.B.品牌在國內市場銷售 Sale H.C.B brand in domestic market
- 自動車用修理工具にH.C.B.のマークを使用することを決定、そして市販を開始。 BENZ suspension bush extractor/installer was awarded patent.
- ENG 工字係調整油壓工具(1999.03.09) HENGL(W124/W201) ヲスベーションポンプツラック抽出器の發明專利(台灣)を正式に取得しました。
- 商標HCB註冊和公司開始參與主要生產專業工具 (1998.09.01)
- The trademark H.C.B was registered and the Company became involved mainly in manufacturing professional tools. (1999.09.01)
- H.C.B 商標專售特許權を審査成功。



## 2012

- 以H.C.B.品牌 正式進入歐洲市場 Sale H.C.B brand in Europe Markets.
- 自動車用修理工具にH.C.B.のマークを使用することを決定、そして歐洲市販事業との直接取引開始。
- 取得 CE 認證 (H.C.B-A1383 電動釘槍)
- 獲得 CE 認證 (H.C.B-A8001 多功能剎車油/油壓引擎拆卸設備)
- 以H.C.B.品牌 正式進入歐洲市場
- 台灣工業生產管理推展協會(設計圖の取り扱方を表彰する。)
- 榮獲台灣發明專利20年 (H.C.B-B1337 電動卡車引擎拆裝架)
- 榮獲 新專型專利 PAT.M 4384/23(H.C.B-A1410 專用球滾卸取卸器(39mm))
- ユニバーサルトルクボルトソングレインバー(39ミリメートル)は商品新型特許權を取得。
- 榮獲 新專型專利 (H.C.B-A1445 運得新型特許權)
- ユニバーサルサスペンションアームレバーは商品新型特許權を取得。



## 2013~2014

- 榮獲 專利 (H.C.B-A1445 撬棍)
- Awarded Patent (H.C.B-A1445 UNIVERSAL SUSPENSION ARM LEVER)
- 榮獲 台灣專利 (H.C.B-A1487 BMW (E81-E88 E90-E93 F2M3)後游錘套拆裝工具組)
- Awarded Taiwan Patent (H.C.B-A1487 BMW (E81-E88 E90-E93 F2M3) REAR TRAILING ARM BUSHING REMOVER & INSTALLER TOOLS)
- 榮獲 德國專利 (H.C.B-B1339 大玉鋼拆卸機 75mm)
- Awarded Germany Patent (H.C.B-B1339 TRUCK KING PIN PRESS 75 TONS)
- KING PIN と アンカー ヒンクチャー (75 トン) はドイツの特許を取得。
- 榮獲 美國專利 (H.C.B-B1117 專利引擎拆裝架)
- Awarded Germany Patent (H.C.B-B1117 UNIVERSAL ENGINE STAND)
- キアアプジョーユニバーサルK/Dラック は米國特許を取得。
- Start building new company (Longder Second 2014.3.3)
- 本社の新工場龍徳二廠で工場擴建開始。



## 1990

- 開始參加臺北 AMPA SHOW 展覽與國外展覽、成功將H.C.B.品牌推廣到國際市場 Start to participate in domestic and international exhibitions and successfully promoting H.C.B brand to international markets.
- 台北と海外國際展覽會を參りました。國際市販でH.C.B.のブランドを成功発売。
- 成立 龍徳精工開發有限公司(原龍徳工業社改制) (2002.4.23)
- Founded Gu Siang Tools Develop Co., Ltd (Gu Siang Industrial Co., reformed) (2002.4.23)
- 龍徳工業社を有限会社 龍徳精工開發と改称。
- 台灣の國立中正大學 龍徳精工開發中心簽約合作 (2002.8.9)
- Formal cooperation with the N.C.C.U (2002.8.9)
- 榮獲 美國專利 (H.C.B-A1081 專利可調式皮帶盤支撐拆手)
- Awarded Taiwan SMEs Innovation Award (Chiayi County Industrial Associations)
- 榮獲 美國專利 (H.C.B-A1081 專利可調式皮帶盤支撐拆手)
- Awarded USA Patent. (H.C.B-A1081 ADJUSTABLE UNIVERSAL CAMSHAFT PULLEY HOLDING TOOL)
- 榮獲 德國專利 (H.C.B-A1108 VW T4 前三角架球接頭拆裝工具組)
- Awarded Germany Patent (H.C.B-A1108 VW T4 FRONT AXLE UPPER BALL-JOINT EXTRACTOR/INSTALLER)
- フロントアクスルアッパーボールジョイント抽出器について、ドイツ特許權を取得。
- 以龍徳創新發明獎 (H.C.B-A1052 雙A臂羊角校正器(改良型))
- Entering National Invention and Creation Award (H.C.B-A1052) DOUBLE WISH-BONE ALIGNMENT TOOLS (IMPROVEMENT)
- 國內で革新研究開發一等をファイナリストに。

## 2002~2006

- 開始參加臺北 AMPA SHOW 展覽與國外展覽、成功將H.C.B.品牌推廣到國際市場 Start to participate in domestic and international exhibitions and successfully promoting H.C.B brand to international markets.
- 台北と海外國際展覽會を參りました。國際市販でH.C.B.のブランドを成功発売。
- 成立 龍徳精工開發有限公司(原龍徳工業社改制) (2002.4.23)
- Founded Gu Siang Tools Develop Co., Ltd (Gu Siang Industrial Co., reformed) (2002.4.23)
- 龍徳工業社を有限会社 龍徳精工開發と改称。
- 台灣の國立中正大學 龍徳精工開發中心簽約合作 (2002.8.9)
- Formal cooperation with the N.C.C.U (2002.8.9)
- 榮獲 美國專利 (H.C.B-A1081 專利可調式皮帶盤支撐拆手)
- Awarded Taiwan SMEs Innovation Award (Chiayi County Industrial Associations)
- 榮獲 美國專利 (H.C.B-A1081 專利可調式皮帶盤支撐拆手)
- Awarded USA Patent. (H.C.B-A1081 ADJUSTABLE UNIVERSAL CAMSHAFT PULLEY HOLDING TOOL)
- 榮獲 德國專利 (H.C.B-A1108 VW T4 前三角架球接頭拆裝工具組)
- Awarded Germany Patent (H.C.B-A1108 VW T4 FRONT AXLE UPPER BALL-JOINT EXTRACTOR/INSTALLER)
- フロントアクスルアッパーボールジョイント抽出器について、ドイツ特許權を取得。
- 以龍徳創新發明獎 (H.C.B-A1052 雙A臂羊角校正器(改良型))
- Entering National Invention and Creation Award (H.C.B-A1052) DOUBLE WISH-BONE ALIGNMENT TOOLS (IMPROVEMENT)
- 國內で革新研究開發一等をファイナリストに。

## 2009

- 榮獲 AMPA SHOW 創新發明特許權第一等 (H.C.B-A1081 專利可調式皮帶盤支撐拆手) Go first in Taipei AMPA Innovation Awards (H.C.B-A1081 ADJUSTABLE UNIVERSAL CAMSHAFT PULLEY HOLDING TOOL) Awarded by the Taiwan International Auto Parts Show (TAPS) in Taipei.
- 榮獲臺北國際汽車零配件展主辦的 AMPA SHOW 綠色能源推薦產品 (H.C.B-A1052) DOUBLE WISH-BONE ALIGNMENT TOOLS (IMPROVEMENT)
- Awarded Taipei AMPA SHOW Green Power recommended product (H.C.B-A1052) DOUBLE WISH-BONE ALIGNMENT TOOLS (IMPROVEMENT)
- 榮獲臺北國際汽車零配件展主辦的 AMPA SHOW 綠色能源推薦產品 (H.C.B-A1117 專利輪軸多功能拆裝架) Awarded Taipei AMPA SHOW Green Power recommended product (H.C.B-A1117 GEAR TYPE UNIVERSAL K/D RACK) オブライブユニバーサル形式(Dラック)特許について、台北國際自動車産業総合展の AMPA SHOW グリーン化製品を表彰して最良の選擇です。
- 榮獲臺北國際汽車零配件展主辦的 AMPA SHOW 綠色能源推薦產品 (H.C.B-A1108 VW T4 前三角架球接頭拆裝工具組) JOINT EXTRACTOR/INSTALLER
- Awarded Taipei AMPA SHOW Green Power recommended product (H.C.B-A1108 VW T4 FRONT AXLE UPPER BALL-JOINT EXTRACTOR/INSTALLER)
- フロントアクスルアッパーボールジョイント抽出器について、台北國際自動車産業総合展の AMPA SHOW グリーン化製品を表彰して最良の選擇です。
- 投保 100 萬美元的產品責任險 Insured \$ 1,000,000 product liability insurance
- 獲得 ISO 9001:2008 認證資格 Obtained ISO 9001:2008 certification company
- Since 2009 our production processes have complied with the ISO 9001:2008 Quality System standards
- 品質マネジメントシステム ISO 9001:2008 認証取得
- 榮獲 德國專利 (H.C.B-B1337 手動卡車多功拆裝架)
- 榮獲 德國專利 (H.C.B-B1337 TRUCK KYD RACK ELECTRICAL)
- Handmade in Taiwan (H.C.B-B1337) は台湾の自治區嘉義縣政府地域産業研究開發推廣計畫 (SBR) 公的扶助支援製品。



## 2010~2011

- 新廠啓用龍徳二廠 2010.2.7)
- Start using new factory (Longder First 2010.2.7)
- 本社の新工場龍徳二廠で工場擴建開始。
- 榮獲 中文電視台 (今日台灣) 節目專題報導 (2010.2.13)
- Obtain Taiwan Today report of Cti TV (2010.2.13)
- 台灣の中文新聞台報導等々で紹介した掲載頂きました。
- 榮獲 嘉義縣政府 99 年度地方產業創新研發推廣計畫 (地方型 SBR) 補助 (H.C.B-A1383 電動釘槍機) Obtain Chiayi County government local industrial innovation and R & D Promotion Program grants (local type SBR) (H.C.B-A1383 ELECTRICAL BRAKE LINING SHOE LOADER) 電氣ブレーキシューングレインローダーは台湾の自治區嘉義縣政府地域産業研究開發推廣計畫
- SBR 公的扶助支援製品。
- H.C.B 商標在中國註冊成功 (2011.1.28)
- Exclusive right to use H.C.B registered trademark in China (2011.1.28)
- 中國でH.C.B.の商標専売特許權を審査成功。
- 榮獲 100 年經濟部科技研究發展專案協同傳統產業技術開發計畫 (CITD) 補助 Obtain CITD Program grants in 2011.
- 經濟部科學產業技術的發展開發推廣計畫 (CITD) 公的扶助支援製品。
- 榮獲 第五次獲得嘉義縣工業會優良會員廠商表揚
- Award Excellent Member recognition from Chiayi County Industrial Associations for fifth times.
- 第五次獲得嘉義縣工業會優良會員廠商表揚

## 2010

- 榮獲 德國專利 (H.C.B-B1337 手動卡車多功拆裝架)
- 榮獲 德國專利 (H.C.B-B1337 TRUCK KYD RACK ELECTRICAL)
- Handmade in Taiwan (H.C.B-B1337) は台湾の自治區嘉義縣政府地域産業研究開發推廣計畫 (SBR) 公的扶助支援製品。

## 2016

- H.C.B 馬路華能工商建教合作培養優秀人才 H.C.B cooperates with Wan-Neng Vocational High School to cultivate talents.
- H.C.B は 高級 工匠 と 契約し、優秀な人材の育成をしています。
- H.C.B-A1117 工具獲得 全國 高中職 汽車科學生 競賽 指定 比賽 工具 Automotive technology of senior high school
- H.C.B-A1117 工具は 全國の 高級の 自動車 修理 コンテストの 指定 工具に 選ばれました。
- H.C.B 龍徳二廠 合作 第 104 年度 高級 中職 學校 職業 教育 師範 公民 學校 機械 研發 活動 (2015/12/03) H.C.B with Wanneng Industrial and Commercial Vocational High School or ganized the 2015th Senior High School Vocational Department Full-time Teacher to private and governmental organization Seminar.
- H.C.B と 龍徳二廠 協力し、104 年度の 高級 職業 專門 學校 師範 公民 學校 機械 研發 活動 (2015/12/03) H.C.B and das Wanneng Industrie- und Wirtschaftssyngnasium organisieren das 2015 Seminar der Oberstufen-Berufsbildung Vollzeit-Lehrer für private und staatliche Organisationen.

## 2016

- H.C.B 馬路華能工商建教合作培養優秀人才 H.C.B cooperates with Wan-Neng Vocational High School to cultivate talents.
- H.C.B は 高級 工匠 と 契約し、優秀な人材の育成をしています。
- H.C.B-A1117 工具獲得 全國 高中職 汽車科學生 競賽 指定 比賽 工具 Automotive technology of senior high school
- H.C.B-A1117 工具は 全國の 高級の 自動車 修理 コンテストの 指定 工具に 選ばれました。
- H.C.B 龍徳二廠 合作 第 104 年度 高級 中職 學校 職業 教育 師範 公民 學校 機械 研發 活動 (2015/12/03) H.C.B with Wanneng Industrial and Commercial Vocational High School or ganized the 2015th Senior High School Vocational Department Full-time Teacher to private and governmental organization Seminar.
- H.C.B と 龍徳二廠 協力し、104 年度の 高級 職業 專門 學校 師範 公民 學校 機械 研發 活動 (2015/12/03) H.C.B and das Wanneng Industrie- und Wirtschaftssyngnasium organisieren das 2015 Seminar der Oberstufen-Berufsbildung Vollzeit-Lehrer für private und staatliche Organisationen.

## 2016





# Brand Story

台灣1990年代

在全球化的加速發展下，國際競爭力已成為工商企業存在與繁榮的關鍵因素。

In 1990's Taiwan.

Under the accelerated development of globalization, the international competitiveness of businesses has become a key in the existence and prosperity.

Taiwan in den 80ern

Unter der beschleunigten Entwicklung der Globalisierung hat sich die internationale Wettbewerbsfähigkeit der Unternehmen zu einem Schlüssel zu Existenz und Wohlstand entwickelt.

由於面臨國內產業外移腳步加快，大廠外移的處境，原本創立於1990/05/01以接單製造機械零件加工之業務為主的鉅祥公司面臨到了訂單縮減的重大問題，但危機未嘗不是轉機？

Faced with the acceleration of the domestic industry relocation, Gu Siang Tools Develop Co., Ltd., founded in 1990/05/01 and doing the manufacture of mechanical parts processing, faced with losing orders. But a crisis is also a turning point, isn't it?

Mit Blick auf die heimische Industrie um den Standort voran zu bringen, wurde Gu Siang Tools Co. Ltd. zur Herstellung und Verarbeitung mechanischer Teile am 05.01.1990 gegründet, trotz verringerter Bestellungen. Aber ist eine Krise nicht auch ein Wendepunkt?

契機來的突然，黃盛彬先生某日接獲友人來電說道：「友人因苦惱修車時遇到無法將零件拆卸更換的問題，所以希望黃盛彬先生可以幫忙解決。」黃盛彬先生熱心助人並馬上前往查看，苦思許久後製作出了修護工具並解決朋友的問題。Opportunity came suddenly, Mr. Hwang Cherng Bin received a call for help one day. It was from a friend who was distressed about how to disassemble and replace parts of the car. Mr. Hwang went and checked. After thinking for a while, Mr. Hwang came up with an idea that he could produce repair tools to solve the problem. And finally Mr. Hwang solved the friend's problem.

Die Gelegenheit kam plötzlich als Mr. Hwang Cherng Bin eines Tages einen Hilferuf eines Freundes bekam, der verzweifelt war wie man Teile auseinander baut und sie ersetzt. Mr. Hwang ging, prüfte und kam nach langer Zeit wieder um ein Reparaturwerkzeug zur Problemlösung herzustellen.

友人感謝之餘，希望向黃盛彬先生購買此修護工具，黃盛彬先生才恍然大悟或許這是可以解決公司面臨訂單縮減的契機，非常感念友人給予的契機。

This friend thanked and would like to purchase this repair tool. Mr. Hwang suddenly realized this can save the company from facing reduction of orders. Until now, Mr. Hwang has an immense gratitude to this friend for the opportunity he gave.

Dieser Freund bedankte sich und wollte gerne das Reparaturwerkzeug kaufen. Mr. Hwang dämmerte, dass das der Firma helfen kann um den verringerten Bestellungen entgegenzuwirken. Bis heute ist Herr Hwang diesem Freund für diese Möglichkeit sehr dankbar.

鉅祥公司致力於汽車修護工具之製造加工，品質長期受業界肯定，於西元2000年自創H. C. B AUTO TOOLS品牌，並以開發BENZ及BMW汽車特殊修護工具為主要目標，提高產品附加價值，另一方面持續開發卡車特殊修護工具、引擎、底盤、輪胎定位、鈹金修護工具，品質優良，造福保養汽車同業，頗受好評。

此外，鉅祥公司也是台灣唯一的卡車工具研發廠商並且榮獲了政府補助。

After that, Company has been concentrating on the production for a wide range of Auto Maintenance Tools and thus built up OBM-H.C.B SPECIALTY TOOLS. H.C.B regards the design and development of BENZ & BMW repair tools as primary object to increase the value of products. On the other hand, company continues to develop special truck repair tools for engines, chassis and tire position. As a result of our high quality products and outstanding customer service, H.C.B has gained a global sales network reaching all over the world. Not only well appreciated by purchasers, but also HCB accesses government subsidies because HCB is the only truck repairing tool manufacturer in Taiwan.

Seitdem ist die Firma mit der Produktion eines weiten Spektrums von Kfz-Wartungswerkzeugen beschäftigt und gründete OBM-H.C.B SPEZIALWERKZEUGE.

H.C.B. ist mit dem Design und der Entwicklung von Kfz-Reparaturwerkzeugen für BENZ & BMW beschäftigt. Auf der anderen Seite setzt das Unternehmen die Entwicklung spezieller Reparaturwerkzeuge für LKW, Motoren, Karosserie und Fahrwerk fort. Als Ergebnis unserer hohen Produktqualität und unseres Kundenservice, hat H.C.B. ein globales Vertriebsnetzwerk erreicht. Nicht nur von seinen Kunden geschätzt, sondern auch der einzige Hersteller von LKW Reparaturwerkzeugen mit Zugang zu staatlichen Subventionen.







**HWANG CHERNG BIN**  
Specialty Tools Inc.

*Photos inside our production facilities*

**SINCE 1990**

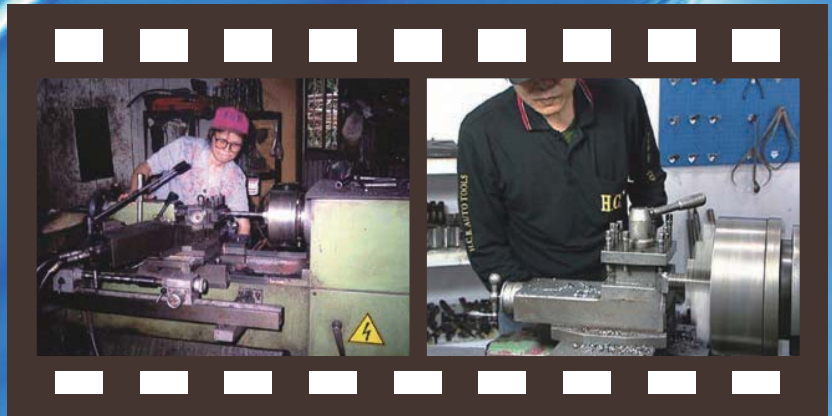









**HWANG CHERNG BIN**  
Specialty Tools Inc.

SINCE 1990

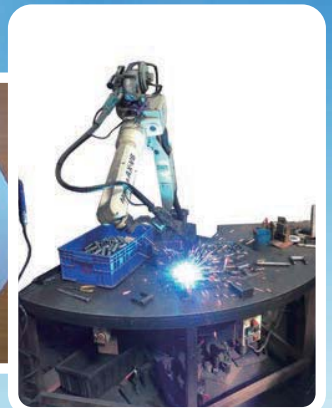
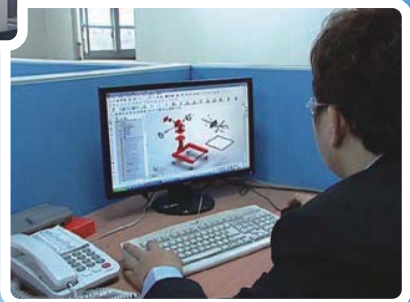
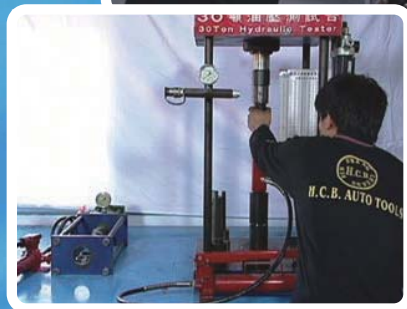





**HWANG CHERNG BIN**  
Specialty Tools Inc.

# PATENT CERTIFICATE

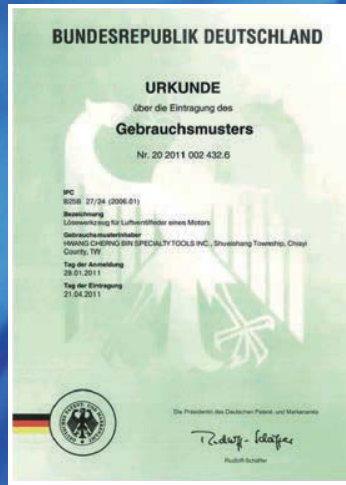





**HWANG CHERNG BIN**  
Specialty Tools Inc.

## European Truck Repair Tool 歐系卡車修護工具

- H.C.B-B1050-1** ..... P01  
SCANIA FRONT WHEEL SHOCK ABSORBER SPRING WASHER SOCKET (Dr. 3/4")  
SCANIA前輪避震器彈簧墊片拆裝套筒(Dr. 3/4")
- H.C.B-B1050-5** ..... P01  
SCANIA REAR AXLES DAMPER ROD SOCKET (Dr. 3/4")  
SCANIA後輪避震器彈簧墊片拆裝套筒(Dr. 3/4")
- H.C.B-B1050-7** ..... P01  
SCANIA REAR WHEEL SHOCK ABSORBER SPRING WASHER SOCKET (Dr. 3/4")  
SCANIA後輪避震器彈簧墊片拆裝套筒(Dr. 3/4")
- H.C.B-A1050-8** ..... P01  
SCANIA 10 WHEELS CAB THIRD AXLE NUT SOCKET (Dr. 3/4", 8 POINTS, 95 mm)  
SCANIA 10輪拖車頭第三軸螺帽套筒(Dr. 3/4" · 8角 · 95 mm)
- H.C.B-A1090** ..... P01  
SCANIA TRUCK (310/320/340) TRANSMISSION SOCKET (Dr. 3/4")  
SCANIA卡車(310/320/340)變速箱專用套筒(Dr. 3/4")
- H.C.B-B1090** ..... P02  
SCANIA TRANSMISSION CLUTCH FRONT MAIN SHAFT SOCKET (Dr. 3/4")  
SCANIA變速箱離合器前主軸螺帽套筒(Dr. 3/4")
- H.C.B-C1090** ..... P02  
SCANIA 8-SPEED BUS TRANSMISSION NUT SOCKET (Dr. 3/4")  
SCANIA變速箱螺帽拆裝套筒(遊覽車8速)(Dr. 3/4")
- H.C.B-D1090** ..... P02  
SCANIA TRANSMISSION CLUTCH FRONT MAIN AXLE NUT SOCKET (Dr. 3/4")  
SCANIA變速箱離合器前主軸螺帽套筒(Dr. 3/4")
- H.C.B-E1090** ..... P02  
SCANIA PTO NUT SOCKET (Dr. 1/2")  
SCANIA卡車PTO螺帽拆裝套筒(Dr. 1/2")
- H.C.B-F1090** ..... P03  
SCANIA(340)TRANSMISSION CLUTCH FRONT MAIN SHAFT SOCKET (Dr. 3/4")  
SCANIA(340)變速箱離合器前主軸螺帽套筒(Dr. 3/4")
- H.C.B-G1090** ..... P03  
SCANIA DIFFERENTIAL REAR AXLE NUT SOCKET (Dr. 3/4")  
SCANIA 差速器後輪軸螺母套筒(Dr. 3/4")
- H.C.B-B1091** ..... P03  
SCANIA TRUCK FRONT WHEEL AXLES HUB EXTRACTOR  
SCANIA卡車前輪仰角HUB拆卸器
- H.C.B-C1091** ..... P03  
SCANIA TRUCK FRONT WHEEL AXLES HUB EXTRACTOR (W/HYDRAULIC CYLINDER)  
SCANIA卡車前輪仰角HUB拆卸器(油壓式)
- H.C.B-A1125** ..... P04  
SCANIA FRONT WHEEL NUT SOCKET (H41, 8 POINTS, 80 mm)  
SCANIA前輪螺帽拆裝套筒(H41 · 8角 · 80 mm)
- H.C.B-B1125** ..... P04  
SCANIA FRONT WHEEL NUT SOCKET (Dr. 3/4", 8 POINTS, 80 mm)  
SCANIA前輪螺帽拆裝套筒(Dr. 3/4" · 8角 · 80 mm)
- H.C.B-C1125** ..... P04  
SCANIA FRONT WHEEL NUT SOCKET (Dr. 1", 8 POINTS, 80 mm)  
SCANIA前輪螺帽拆裝套筒(Dr. 1" · 8角 · 80 mm)
- H.C.B-A1126** ..... P04  
SCANIA REAR WHEEL NUT SOCKET (8 POINTS, 100 mm)  
SCANIA後輪螺帽拆裝套筒(8角 · 100 mm)
- H.C.B-B1126** ..... P05  
SCANIA REAR WHEEL NUT SOCKET (Dr. 3/4", 8 POINTS, 100 mm)  
SCANIA後輪螺帽拆裝套筒(Dr. 3/4" · 8角 · 100 mm)
- H.C.B-C1126** ..... P05  
SCANIA REAR WHEEL SOCKET (Dr. 1", 8 POINTS, 100 mm)  
SCANIA後輪螺帽拆裝套筒(Dr. 1" · 8角 · 100 mm)
- H.C.B-A1167** ..... P05  
SCANIA, BENZ (W203 / W209) WRENCH SOCKET (FLUID RESERVOIR ON CONDENSER) (Dr. 1/2", 27 mm)  
SCANIA, BENZ (W203 / W209) 冷凝器貯油槽套筒扳手 (Dr. 1/2", 27 mm)
- H.C.B-A1227** ..... P05  
SCANIA TRUCK FLYWHEEL ROTATOR (Dr. 1/2")  
SCANIA卡車曲軸飛輪轉動器(Dr. 1/2")
- H.C.B-A1236** ..... P06  
SCANIA (320/340/360) KING PIN EXTRACTOR (10 WHEELS)  
SCANIA (320/340/360)大王銷拆卸器(10輪)
- H.C.B-A1257** ..... P06  
SCANIA (340) ELECTROMAGNETIC INJECTION VALVE CAP SOCKET (Dr. 1/2", 8 POINTS, 38 mm)  
SCANIA (340)電磁閥噴油嘴蓋套筒(Dr. 1/2", 8角, 38 mm)
- H.C.B-A1278** ..... P06  
SCANIA (420) AXLE HUB NUT SOCKET (Dr. 3/4", 8 TEETH)  
SCANIA (420)輪軸螺帽套筒(Dr. 3/4", 8齒)
- H.C.B-A1265** ..... P06  
SCANIA (320/340) / VOLVO(FM12) PITMAN ARM PULLER (Dr. 3/4", 58 mm)  
SCANIA (320/340)/ VOLVO(FM12)方向機搖臂拆卸器 (Dr. 3/4", 58 mm)
- H.C.B-B1265** ..... P07  
SCANIA(320/340)/VOLVO (FM12)PITMAN ARM PULLER(58 mm) (W/HYDRAULIC CYLINDER)  
SCANIA (320/340) / VOLVO(FM12)方向機搖臂拆卸器 (58 mm) (油壓式)



**HWANG CHERNG BIN**  
Specialty Tools Inc.

- H.C.B-B1277** ..... P07  
SCANIA (320/340) / VOLVO (FM12)/  
MAN (FE414) STEERING MECHANISM  
BEARING PULLER  
SCANIA (320/340) / VOLVO (FM12)/ MAN (FE414)  
方向機培林拆卸組
- H.C.B-A1284** ..... P07  
SCANIA TRANSMISSION REAR OIL SEAL  
INSTALLER  
SCANIA變速箱後油封安裝器
- H.C.B-A1181** ..... P08  
SCANIA & VOLVO SPRING PIN METAL  
BUSH REMOVAL/INSTALLATION TOOL KIT  
(W/ HYDRAULIC CYLINDER)  
SCANIA & VOLVO卡車彈簧銷拆裝工具組(油壓式)
- H.C.B-A1319** ..... P08  
SCANIA (310/320) CRANKSHAFT REAR  
OIL SEAL INSTALLER  
SCANIA (310/320)曲軸後油封安裝器
- H.C.B-A1350** ..... P08  
SCANIA RADIATOR ADAPTOR  
SCANIA水箱快速接頭
-  **H.C.B-A1606** ..... P09  
SCANIA 340/380 (EURO 4) CRANKSHAFT  
FRONT/REAR OIL SEAL INSTALLER (PR SERIES)  
SCANIA 340/380(4期環保車)  
曲軸前後油封安裝工具組(PR系列)
-  **H.C.B-B1606** ..... P09  
SCANIA (114) 340/360/380 CRANKSHAFT  
FRONT OIL SEAL INSTALLER  
SCANIA(114) 340/360/380曲軸前油封安裝工具
-  **H.C.B-B1402** ..... P09  
SCANIA (340/360/380) VALVE SPRING  
COMPRESSOR TOOL KIT  
SCANIA (340/360/380) 汽門彈簧壓縮工具組
-  **H.C.B-A1630** ..... P10  
SCANIA (114) INJECTOR REMOVAL/  
INSTALLATION TOOL KIT  
SCANIA(114)噴油嘴拆裝工具組
- H.C.B-A2228** ..... P10  
SCANIA SOCKET (Dr. 3/4", 90 mm) (E28)  
SCANIA 套筒(Dr. 3/4" · 90 mm)(E28)
- H.C.B-A1353** ..... P10  
KNORR-BREMSE DISC BRAKE  
SERVICE KIT  
卡車碟煞(KNORR-BREMSE)維修組
- H.C.B-B1353** ..... P10  
CALLIPER ADJUSTER SOCKET  
(H24, 5 TEETH)  
卡鉗調整器套筒(H24, 5齒)
- H.C.B-A2193** ..... P11  
DIESEL INJECTOR PULLER  
柴油噴油嘴拆卸器
- H.C.B-A1444** ..... P11  
SCANIA TRUCK (310/320)REAR WHEEL  
AXLES HUB REMOVER  
SCANIA (310/320) 卡車後輪HUB拆卸器
- H.C.B-A1478** ..... P11  
SCANIA 310 (112) & 320(113) EXTRACTOR  
SCANIA 310(112) & 320(113)  
傳動軸接座&曲軸油封接座拆卸器
- H.C.B-A1490** ..... P12  
SCANIA 113 (10 SPEED) TRANSMISSION MAINSHAFT/  
COUNTERSHAFT/ INPUT SHAFT BEARING PULLER  
SCANIA 113 (10速) 變速箱主軸/副軸/輸入軸 培林拆卸器
-  **H.C.B-B1490** ..... P12  
SCANIA 113 (10 SPEED) TRANSMISSION MAINSHAFT/  
COUNTERSHAFT/ INPUT SHAFT BEARING INSTALLER  
SCANIA 113 (10速) 變速箱主軸/副軸/輸入軸培林安裝
-  **H.C.B-C1490** ..... P12  
SCANIA 113 (10 SPEED) TRANSMISSION MAINSHAFT/  
COUNTERSHAFT/ INPUT SHAFT BEARING REMOVAL/  
INSTALLATION TOOL  
SCANIA 113 (10速) 變速箱主軸/ 副軸/ 輸入軸 培林拆裝工具
- H.C.B-D1391** ..... P13  
SCANIA REAR WHEEL HUB INNER  
BEARING EXTRACTOR  
SCANIA 後輪軸內側培林拆卸器
- H.C.B-E1391** ..... P13  
SCANIA REAR WHEEL HUB INNER  
BEARING INSTALLER  
SCANIA 後輪軸內側培林安裝器
- H.C.B-A1050-2** ..... P13  
BPW TRAILER REAR WHEEL SOCKET  
(12 TONS) (H41, OVAL, 111 mm)  
BPW 板車輪軸蓋拆裝套筒 (12噸)(H41, 橢圓, 111 mm)
- H.C.B-B1050-2** ..... P13  
BPW TRAILER REAR WHEEL SOCKET  
(6.5~9 TONS) (Dr.3/4", OVAL, 95 mm)  
BPW 板車輪軸蓋拆裝套筒 (6.5~9噸)  
(Dr.3/4", 橢圓, 95 mm)
- H.C.B-A1050-3** ..... P14  
BPW TRAILER REAR WHEEL SOCKET  
(FORMER 16 TONS) (H41, 8 POINTS, 120 mm)  
BPW 板車輪軸蓋拆裝套筒 (舊型16噸)(H41, 8角, 120 mm)
- H.C.B-B1050-3** ..... P14  
BPW TRAILER REAR WHEEL SOCKET  
(NEW 16 TONS) (Dr. 3/4", 8 POINTS, 110 mm)  
BPW 板車輪軸蓋拆裝套筒(新型16噸)  
(Dr. 3/4", 8角, 110 mm)
- H.C.B-A1050-4** ..... P14  
BPW TRAILER REAR WHEEL SOCKET  
(12 TONS) (H41, 8 POINTS, 109 mm)  
BPW 板車輪軸蓋拆裝套筒(12噸) (H41, 8角, 109 mm)
- H.C.B-A1050-6** ..... P14  
BPW TRAILER REAR WHEEL SOCKET  
(12 TONS) (Dr. 1", OVAL, 111 mm)  
BPW 板車輪軸蓋拆裝套筒(12噸) (Dr. 1", 橢圓, 111 mm)
- H.C.B-B1050-6** ..... P15  
BPW TRAILER REAR WHEEL SOCKET  
(12 TONS) (Dr. 1", OVAL, 108 mm)  
BPW 板車輪軸蓋拆裝套筒(12噸) (Dr. 1", 橢圓, 108mm)





**HWANG CHERNG BIN**  
Specialty Tools Inc.

<b>H.C.B-C1050-6</b> BPW TRAILER REAR WHEEL SOCKET (13~14 TONS) (Dr. 1", OVAL, 120 mm) BPW 板車輪軸蓋拆裝套筒(13~14噸) (Dr. 1", 橢圓, 120 mm)	P15	<b>H.C.B-A1203</b> MAN TRUCK DIFFERENTIAL BEARING EXTRACTOR MAN卡車差速器培林拔卸器	P19
<b>H.C.B-D1050-6</b> BPW TRAILER REAR WHEEL SOCKET (Dr. 1", 109 mm) BPW板車輪軸蓋拆裝套筒 (Dr. 1", 109 mm)	P15	<b>H.C.B-A1228</b> MAN TRUCK TRANSMISSION SOCKET (Dr. 3/4") MAN卡車變速箱專用套筒(Dr. 3/4")	P19
<b>H.C.B-A1066-1</b> BPW 12 TONS AXLE EXTRACTOR (M125 x P2.0) BPW 12噸輪軸拔取器(M125 x P2.0 · 外牙)	P15	<b>H.C.B-A1273</b> MAN (FE410A/FE414) PITMAN ARM PULLER (Dr. 3/4", 67mm) MAN (FE410A/FE414)卡車方向機搖臂拆卸器 (Dr. 3/4", 67 mm)	P19
<b>H.C.B-A1066-2</b> BPW 16 TONS AXLE EXTRACTOR (M155 x P3.0) BPW 16噸輪軸拔取器 (M155 x P3.0 · 外牙)	P16	<b>H.C.B-A1274</b> MAN (FE410A) STEERING MECHANISM OIL SEAL SOCKET (Dr. 1/2", 4 POINTS) MAN (FE410A)卡車方向機油封套筒(Dr. 1/2", 4點)	P20
<b>H.C.B-A1066-3-1</b> BPW 12 TONS AXLE EXTRACTOR (M135 x P2.0) BPW 12噸輪軸拔取器 (M135 x P2.0 · 內牙)	P16	<b>H.C.B-A1239</b> MAN TRUCK FRONT WHEEL HUB REMOVER MAN卡車前輪HUB拔卸器	P20
<b>H.C.B-A1066-3-2</b> BPW 12 TONS AXLE EXTRACTOR (M136 x P2.5) BPW 12噸輪軸拔取器 (M136 x P2.5 · 內牙)	P16	<b>H.C.B-A1328</b> MAN TGA FRONT WHEEL AXLE NUT SOCKET (Dr. 3/4", H60, 93 mm) MAN TGA卡車前輪軸及後輪舉升軸螺帽套筒 (Dr. 3/4", H60, 93 mm)	P20
<b>H.C.B-A1171</b> BPW 12 TONS ROLLER BEARING AXLE NUT SOCKET (Dr. 3/4") BPW 12噸板車輪軸螺母套筒(Dr. 3/4")	P16	<b>H.C.B-A1329</b> MAN TGA DRIVE AXLE NUT SOCKET (Dr. 3/4", H60, 158 mm) MAN TGA卡車帶動軸螺帽套筒(Dr. 3/4", H60, 158 mm)	P20
<b>H.C.B-B1171</b> BPW 6.5 ~9 TONS ROLLER BEARING AXLE NUT SOCKET (Dr. 3/4") BPW 6.5~9噸板車輪軸螺母套筒(Dr. 3/4")	P17	<b>H.C.B-A1344</b> MAN, BENZ DIFFERENTIAL REAR NUT SOCKET (Dr. 3/4", 6 TEETH) MAN, BENZ 卡車差速器後螺母套筒(Dr. 3/4", 6齒)	P21
<b>H.C.B-C1171</b> BPW 13~14 TONS ROLLER BEARING AXLE NUT SOCKET (Dr. 3/4") BPW 13~14噸板車輪軸螺母套筒(Dr. 3/4")	P17	<b>H.C.B-A1345</b> MAN, BENZ DRIVE AXLE NUT SOCKET (Dr. 3/4", H60, 6 TEETH) MAN, BENZ 卡車帶動軸螺母套筒(Dr. 3/4", H60, 6齒)	P21
<b>H.C.B-A1281</b> BPW 16 TONS ROLLER AXLE NUT SOCKET (Dr. 3/4", 6POINTS, 85 mm) BPW 16噸輪軸螺母套筒(Dr. 3/4", 6角, 85 mm)	P17	<b>H.C.B-A2018-19</b> MAN TRUCK OIL FILTER WRENCH (Dr. 1/2", 18 POINTS, 135 mm) MAN 卡車機油芯扳手 (Dr 1/2", 18角, 135 mm)	P21
<b>H.C.B-A1071</b> MAN(422/403), BENZ TRUCK DIESEL INJECTION VALVE SOCKET MAN (422/403), BENZ卡車柴油噴嘴專用套筒	P18	<b>H.C.B-A2132</b> MAN STAR-E IMPACT SOCKET (Dr. 3/4", E18/E20) (FOR HGV CYLINDER-HEAD BOLT) MAN卡車星型衝擊式套筒(Dr. 3/4", E18/E20)(氣缸床用)	P22
<b>H.C.B-A1075</b> MAN FRONT WHEEL HUB EXTRACTOR MAN卡車前輪HUB拔卸器	P18	<b>H.C.B-B2132</b> MAN STAR-E IMPACT SOCKET KIT (FOR HGV CYLINDER-HEAD BOLT) MAN卡車星型衝擊式套筒(氣缸床用)	P22
<b>H.C.B-B1075</b> MAN FRONT WHEEL HUB INSTALLER MAN卡車前輪HUB安裝器	P18	<b>H.C.B-C2132</b> MAN STAR-E IMPACT SOCKET SET (FOR HGV CYLINDER-HEAD BOLT) (6PCS) (E18/E20/E22/E24/17mm/19mm) (6 POINT) MAN卡車星型衝擊式套筒組(氣缸床用)(6PCS) (E18/E20/E22/E24/17 mm/19 mm) (6 角)	P22
<b>H.C.B-A1172</b> MAN AXLE BEARING EXTRACTOR MAN卡車輪軸培林拔卸器	P18		
<b>H.C.B-B1172</b> MAN TRACTOR (33460/410/414) AXLE BEARING EXTRACTOR MAN卡車前輪(33460/410/414)輪軸培林拆卸器	P19		



**HWANG CHERNG BIN**  
Specialty Tools Inc.

<b>H.C.B-B1102</b> ..... P23 <b>EUROPEAN TRUCK BALL JOINT REMOVER</b> (39 mm) <b>PAT. M 362085</b> 歐系卡車球接頭拆卸器(39 mm)	<b>H.C.B-A1335</b> ..... P26 <b>VOLVO (FM12) KING PIN UPPER COVER</b> <b>SOCKET (Dr. 3/4", 6 POINTS, 80 mm)</b> VOLVO (FM12)卡車大王銷上蓋套筒 (Dr. 3/4", 6角, 80 mm)
<b>H.C.B-A1169</b> ..... P23 <b>VOLVO TRUCK FRONT/REAR BRAKE SHOE</b> <b>LINING INSIDE CALIPER</b> VOLVO卡車前後輪煞車來令片更換卡鉗夾	<b>H.C.B-B1350</b> ..... P26 <b>VOLVO RADIATOR ADAPTOR</b> VOLVO卡車水箱快速接頭
<b>H.C.B-A1175</b> ..... P23 <b>VOLVO (MP7) FLYWHEEL TURNING TOOL</b> VOLVO (MP7)卡車曲軸飛輪轉動器	<b>H.C.B-A1363</b> ..... P27 <b>VOLVO TRUCK KING PIN BEARING PULLER</b> VOLVO卡車大王銷培林拆卸器
<b>H.C.B-B1175</b> ..... P24 <b>VOLVO (MP8/MP10) FLYWHEEL TURNING TOOL</b> VOLVO (MP8/MP10)曲軸飛輪轉動工具	<b>H.C.B-A1380</b> ..... P27 <b>VOLVO TRUCK FAN BEARING BASE</b> <b>SOCKET (Dr. 1/2")</b> VOLVO卡車風扇軸承底座套筒(Dr. 1/2")
<b>H.C.B-A1176</b> ..... P24 <b>VOLVO WHEEL SHAFT COVER SOCKET</b> (Dr. 3/4", 8 POINTS, 115 mm) VOLVO卡車輪軸蓋套筒(Dr. 3/4", 8角, 115 mm)	<b>H.C.B-A1393</b> ..... P27 <b>VOLVO (FM12) TRUCK INJECTOR</b> <b>SLEEVE REMOVER / INSTALLER KIT</b> VOLVO(FM12)噴油嘴銅套拆裝工具組
<b>H.C.B-A1186</b> ..... P24 <b>VOLVO SHOCK ABSORBER SPRING</b> <b>WASHER REMOVAL SOCKET (H27) (FRONT)</b> VOLVO避震器彈簧墊片拆卸套筒(H27)(前)	<b>H.C.B-B1393</b> ..... P28 <b>VOLVO (FM) TRUCK INJECTOR SLEEVE</b> <b>REMOVER/INSTALLER KIT</b> VOLVO(FM)噴油嘴銅套拆裝工具組
<b>H.C.B-B1186</b> ..... P24 <b>VOLVO SHOCK ABSORBER SPRING WASHER</b> <b>REMOVAL SOCKET(Dr. 3/4") (REAR)</b> VOLVO避震器彈簧墊片拆卸套筒(Dr. 3/4")(後)	<b>H.C.B-A1402</b> ..... P28 <b>VOLVO (FM) VALVE SPRING</b> <b>COMPRESSOR TOOL KIT</b> VOLVO (FM) 氣門彈簧壓縮工具組
<b>H.C.B-A1229</b> ..... P25 <b>VOLVO (FM12) TRANSMISSION CLUTCH</b> <b>CALIPER PISTONS DEPTH LEVEL GAUGE</b> VOLVO (FM12)卡車變速箱離合器分泵深度量規	<b>H.C.B-A2018-3</b> ..... P29 <b>VOLVO TRUCK OIL FILTER WRENCH</b> (Dr. 1/2" , 15 POINTS, 107 mm) VOLVO卡車機油芯扳手(Dr.1/2", 15角, 107 mm)
<b>H.C.B-A1238</b> ..... P25 <b>VOLVO TRUCK AXLE NUT SOCKET</b> (Dr. 3/4", 6 POINTS, 105 mm) VOLVO卡車輪軸螺帽套筒(Dr.3/4", 6角, 105 mm)	<b>H.C.B-A1462</b> ..... P29 <b>VOLVO (FM/FH) INJECTOR NOZZLE PULLER</b> VOLVO(FM/FH)噴油嘴拆卸工具
<b>H.C.B-B1238</b> ..... P25 <b>VOLVO TRUCK AXLE NUT SOCKET</b> (Dr. 3/4", 6 POINTS, 95 mm) VOLVO卡車輪軸螺帽套筒(Dr.3/4", 6角, 95 mm)	<b>H.C.B-A1423</b> ..... P29 <b>VOLVO (FM12) HYDRAULIC LIFT CYLINDER</b> <b>REMOVAL/INSTALLATION KIT</b> VOLVO (FM12)舉升液壓缸拆裝工具
<b>H.C.B-A1246</b> ..... P25 <b>VOLVO TRUCK CAB SHOCK ABSORBER</b> <b>UPPER BASE NUT EXTRACTOR / INSTALLER</b> VOLVO卡車車頭避震器上座螺帽拆裝器	 <b>H.C.B-F1560</b> ..... P30 <b>VOLVO (FM12) (EV90/EV91) TRUCK DIFFERENTIAL</b> <b>MAIN SHAFT BEARING EXTRACTOR</b> VOLVO (FM12)(EV90/EV91)卡車差速器主軸培林拆卸器
<b>H.C.B-A1247</b> ..... P25 <b>VOLVO TRUCK OIL FILTER WRENCH</b> (Dr. 1/2", 15POINTS, 107 mm) VOLVO卡車機油芯扳手(Dr.1/2", 15角, 107 mm)	 <b>H.C.B-A1608</b> ..... P30 <b>VOLVO (FM12) (FM) (FH) STRAIGHT LINK BALL</b> <b>JOINT REMOVER TOOL</b> VOLVO (FM12) (FM) (FH)直拉桿球接頭拆卸工具
<b>H.C.B-A1269</b> ..... P26 <b>SCANIA/VOLVO TRUCK CAB REMOVAL</b> <b>WRENCH (12 POINTS, 22 mm)</b> SCANIA /VOLVO 拖車頭拆卸扳手(12角, 22 mm)	 <b>H.C.B-A1609</b> ..... P30 <b>VOLVO (FM/FH) MAIN SHAFT BEARING</b> <b>INSTALLER TOOL</b> VOLVO (FM/FH) 差速器主軸培林安裝工具





**HWANG CHERNG BIN**  
Specialty Tools Inc.

 <b>H.C.B-A1614</b> ..... P31 VOLVO (FM12) (FM) FRONT/REAR STABILIZER BALL JOINT REMOVER (43 mm) VOLVO (FM12) (FM)前後平衡軸吊桿球接頭拆卸工具(43 mm)		
 <b>H.C.B-A1615</b> ..... P31 VOLVO (FM) TRUCK ABS SENSOR WHEEL FITTING TOOL VOLVO(FM) 卡車ABS齒環安裝工具		
 <b>H.C.B-A1616</b> ..... P31 VOLVO TRUCK FITTING TIMING GEAR COVER INSTALLER TOOL VOLVO卡車時規蓋安裝工具		
 <b>H.C.B-A1617</b> ..... P32 VOLVO TRUCK REMOVING AND FITTING TIMING GEAR PLATE TOOL VOLVO卡車正時齒輪板工具		
 <b>H.C.B-A1626</b> ..... P32 VOLVO (FM) TRUCK DISC BRAKE CALIPER FIXING SCREW WRENCH (Dr. 1") VOLVO(FM)卡車碟煞卡鉗固定螺絲扳手(Dr. 1)		
 <b>H.C.B-A1627</b> ..... P32 VOLVO (FM) TRUCK REAR WHEEL AXLE BEARING/ OIL SEAL INSTALLER VOLVO(FM)卡車後輪軸培林/油封安裝工具		
 <b>H.C.B-B1627</b> ..... P32 VOLVO (FM) TRUCK FRONT WHEEL AXLE BEARING/ OIL SEAL INSTALLER VOLVO(FM)卡車前輪軸培林/油封安裝工具		
 <b>H.C.B-C1627</b> ..... P33 VOLVO (FM) TRUCK LIFTING AXLE BEARING/ OIL SEAL INSTALLER VOLVO(FM)卡車舉升軸培林/油封安裝工具		
 <b>H.C.B-A1646</b> ..... P33 VOLVO (FM/FH) (12 SPEED) TRANSMISSION MAINSHAFT BEARING/ GEAR REMOVAL TOOL VOLVO (FM/FH) (12速) 變速箱主軸培林/齒輪拆卸工具		
 <b>H.C.B-A1654</b> ..... P33 VOLVO (FM) INSTALLER OUTPUT SHAFT SEAL VOLVO (FM) 變速箱後油封安裝工具		
 <b>H.C.B-A1663</b> ..... P33 DAF (CF) 35 TONS DIFFERENTIAL FRONT/ REAR BEARINGS REMOVAL/ INSTALLATION TOOL DAF (CF) 35噸差速器前後培林拆裝工具組		
<b>H.C.B-A1454</b> ..... P34 DAF CF85 43 TONS TRAILER DRIVE SHAFT SOCKET (EURO 4 & EURO 5) (Dr. 3/4") DAF CF85 43 噸拖車頭傳動軸套筒 (四期、五期環保車)(Dr. 3/4")		
<b>H.C.B-A1465</b> ..... P34 DAF PISTON RING INSTALLATION SLEEVE TOOL DAF 汽缸套活塞安裝器		
<b>H.C.B-A1521</b> ..... P34 DAF(LF) 12/17 TONS OIL FILTER WRENCH (EURO 4/5) (Dr. 1/2", 10 FLUTES, 92 mm) DAF(LF)12/17 噸 (EURO 4/5期)機油芯扳手 (Dr.1/2", 10 角, 92 mm)		
<b>H.C.B-A1190</b> ..... P35 DAF STEERING LINKAGE FIXING BASE SOCKET (Dr. 1/2") DAF卡車方向機連桿固定座拆裝套筒(Dr. 1/2")		
<b>H.C.B-A1244</b> ..... P35 DAF TRUCK FLYWHEEL ROTATOR (35-42 TONS) (EURO 3) DAF卡車曲軸飛輪轉動器(35-42噸)(三期環保)		
<b>H.C.B-A1398</b> ..... P35 DAF TRUCK FLYWHEEL ROTATOR (35-42 TONS) (EURO 4) DAF卡車曲軸飛輪轉動器(35-42噸)(四期環保)		
<b>H.C.B-A1432</b> ..... P35 DAF TRANSMISSION NEUTRAL POSITION ADJUSTMENT TOOL DAF變速箱空檔位置校正器		
<b>H.C.B-A1271</b> ..... P36 DAF TRUCK TRANSMISSION ASSEMBLY REMOVAL/INSTALLATION KIT (ZF 16S) DAF卡車變速箱拆裝吊具 (ZF 16速)		
<b>H.C.B-A1271-A</b> ..... P36 DAF TRUCK TRANSMISSION ASSEMBLY REMOVAL/INSTALLATION SLING (ZF 16S) DAF卡車變速箱拆裝吊具(ZF 16速)		
<b>H.C.B-A1271-B</b> ..... P36 DAF TRUCK TRANSMISSION MAIN SHAFT AND COUNTER SHAFT FIXED SEAT (ZF16S) DAF卡車變速箱主副軸固定座(ZF 16速)		
<b>H.C.B-A1271-C</b> ..... P36 DAF TRUCK PLANETARY GEAR GROUP SUPPORTING PLATE (ZF 16S) DAF卡車變速箱缸體支撐板(ZF 16速)		
<b>H.C.B-A1271-D</b> ..... P36 DAF TRUCK TRANSMISSION PLANETARY GEAR ASSEMBLY SLING (ZF16S) DAF卡車變速箱行星齒輪總成吊具(ZF 16速)		
<b>H.C.B-A1271-E</b> ..... P36 DAF TRUCK TRANSMISSION PLANETARY GEAR RETAINING BOLT (ZF16 S) DAF卡車變速箱主軸撥叉螺柱(ZF 16速)		
<b>H.C.B-A1271-F</b> ..... P36 DAF TRUCK TRANSMISSION MAIN SHAFT BEARING INSTALLER (ZF16S) DAF卡車變速箱主軸培林安裝器(ZF 16速)		
<b>H.C.B-A1271-G</b> ..... P36 DAF TRUCK TRANSMISSION MAIN SHAFT BEARING INSTALLER (ZF16S) DAF卡車變速箱主軸培林安裝器(ZF 16速)		
<b>H.C.B-A1271-H</b> ..... P36 DAF TRUCK TRANSMISSION MAIN SHAFT BEARING INSTALLER (ZF16S) DAF卡車變速箱主軸培林安裝器(ZF 16速)		

	<b>H.C.B-B1271</b>	P37	<b>H.C.B-A1384</b>	P42
	TRUCK TRANSMISSION/ BEARING/ SHAFT SLEEVE/ GEAR PULLER SET (ZF16S) 卡車變速箱/培林/軸套/齒輪拆卸工具組(ZF 16速)		BENZ TRUCK TRANSMISSION OIL LEVEL GAUGE BENZ卡車變速箱機油尺	
	<b>H.C.B-C1271</b>	P37	<b>H.C.B-A1387</b>	P42
	TRUCK TRANSMISSION / BEARING / SHAFT SLEEVE / GEAR PULLER KIT (ZF16S221-16S251) 卡車變速箱/培林/軸套/齒輪拆卸工具組(ZF16S221-16S251)		BENZ AXLE NUT SOCKET (H36, 12 POINTS, 95 mm) BENZ輪軸螺帽套筒(H36, 12角, 95 mm)	
	<b>H.C.B-A1409</b>	P38	<b>H.C.B-B1387</b>	P42
	DAF XLR (EURO 4) PROPELLER SHAFT CENTER BEARING NUT SOCKET DAF 四期 XLR 傳動軸中間軸承固定套筒		IVECO AXLE NUT SOCKET (H36, 12 POINTS, 110 mm) IVECO輪軸螺帽套筒(H36, 12角, 110 mm)	
	<b>H.C.B-A1602</b>	P38	<b>H.C.B-C1387</b>	P42
	DAF TRUCK DIFFERENTIAL V TORSION BAR BUSH REMOVAL / INSTALLATION TOOL KIT (70 mm) DAF 卡車差速器V型扭力桿鐵套拆裝工具組(70 mm)		IVECO AXLE NUT SOCKET (H36, 12 POINTS, 105 mm) IVECO輪軸螺帽套筒(H36, 12角, 105 mm)	
	<b>H.C.B-B1602</b>	P39	<b>H.C.B-A1561</b>	P43
	DAF TRUCK DIFFERENTIAL V TORSION BAR BUSH REMOVAL / INSTALLATION TOOL KIT (75 mm) DAF 卡車差速器V型扭力桿鐵套拆裝工具組(75 mm)		IVECO WHEEL NUT SOCKET (Dr.1",85 mm,12 POINT) IVECO 輪軸螺帽套筒(Dr. 1",85 mm,12角)	
	<b>H.C.B-A1636</b>	P39	<b>H.C.B-A1411-95</b>	P43
	DAF(CF) CRANKSHAFT FRONT OIL SEAL INSTALLER (35-42TONS) (EURO 4/5) DAF(CF)曲軸前油封安裝器(35-42噸) (4/5期環保)		BENZ AXLE NUT SOCKET (H36, 6 POINTS, 95 mm) BENZ 輪軸螺帽套筒(H36, 6角, 95 mm)	
	<b>H.C.B-A1242</b>	P40	<b>H.C.B-A1411-98</b>	P43
	BENZ ACTROS PITMAN ARM PULLER (Dr. 3/4", 42 mm) BENZ ACTROS卡車方向機搖臂拆卸器(Dr. 3/4",42 mm)		IVECO AXLE NUT SOCKET (H36, 6 POINTS, 98 mm, Dr.3/4") IVECO 輪軸螺帽套筒 (H36, 6角, 98 mm, Dr.3/4")	
	<b>H.C.B-A1263</b>	P40		P44
	TRUCK POSITION SENSOR SOCKET (Dr. 1/2", 8 POINTS, 27 mm) 卡車位置感應器套筒(Dr. 1/2",8角,27 mm)		<b>H.C.B-A1601</b>	
	<b>H.C.B-A1314</b>	P40	IVECO 3.5/7 TONS OIL FILTER WRENCH (Dr. 1/2",10 FLUTES, 94.5 mm) IVECO 3.5/7 噸機油芯扳手(Dr. 1/2", 10角, 94.5 mm)	
	BENZ & MAN TRUCK FRONT AXLE NUT SOCKET (Dr. 3/4", SW 60mm, 76 mm) BENZ & MAN 卡車前輪軸螺帽套筒 (Dr. 3/4",SW 60 mm,76 mm)			P44
	<b>H.C.B-B1314</b>	P40	<b>H.C.B-A1603</b>	
	BENZ & MAN TRUCK FRONT AXLE NUT SOCKET (Dr. 3/4", SW 56 mm, 71 mm) BENZ & MAN卡車前輪軸螺帽套筒 (Dr. 3/4",SW 56 mm,71 mm)		IVECO 3.5/ 7 TONS TIRE NUT CROSS WRENCH (27 mm) IVECO 3.5/7噸輪胎螺絲十字扳手(27 mm)	
	<b>H.C.B-A1441</b>	P41		P44
	BENZ TRUCK (2640) DRIVE AXLE NUT REMOVAL /INSTALLATION SOCKET (Dr. 3/4",6 TEETH) BENZ卡車(2640)帶動軸螺帽拆裝套筒(Dr. 3/4",6齒)		<b>H.C.B-A1618</b>	
	<b>H.C.B-A1442</b>	P41	IVECO DUAL GEAR ENGINE FLYWHEEL ROTATOR (WITH 2 GEARS) IVECO DUAL 齒輪引擎飛輪轉動器(2齒)	
	BENZ TRUCK (2640) LIFT AXLE NUT REMOVAL /INSTALLATION SOCKET (Dr. 3/4",6 TEETH) BENZ卡車(2640)舉升軸螺帽拆裝套筒(Dr. 3/4",6齒)			P44
	<b>H.C.B-A1443</b>	P41	<b>H.C.B-A1634</b>	
	BENZ TRUCK WHEEL AXLE NUT SOCKET (Dr. 1") BENZ卡車輪軸螺帽套筒(Dr. 1")		RENAULT MAGNUM TRUCK ENGINE FLYWHEEL ROTATOR (Dr. 1/2") RENAULT MAGNUM 卡車引擎飛輪轉動器(Dr. 1/2")	
			<b>H.C.B-A1280</b>	P45
			YORK REAR WHEEL NUT SOCKET (8 POINTS, 95 mm) YORK後輪螺帽拆裝套筒(8角, 95 mm)	
			<b>H.C.B-A1422</b>	P45
			BENZ TRUCK FILTER WRENCH (46 mm) BENZ 卡車機油芯套筒(46 mm)	
			<b>H.C.B-A1282</b>	P45
			YORK ROTATING AXLE SHAFT TIE ROD BUSH REMOVE / INSTALLATION TOOL KIT YORK自轉軸橫拉桿鐵套拆裝工具組	





<b>H.C.B-A1283</b> FUWA WHEEL SHAFT COVER SOCKET (Dr. 1", 8 POINTS, 123 mm) 福華板車輪軸蓋拆裝套筒(Dr.1",8角,123 mm)	P45	<b>H.C.B-A1493</b> BENZ & MAN FLYWHEEL ROTATING TOOL (WITH 3 GEARS) (Dr. 1/2") BENZ & MAN卡車飛輪轉動工具(3齒) (Dr.1/2")	P51
<b>H.C.B-A2178</b> TRUCK INJECTION NOZZLE SOCKET 卡車噴油嘴拆裝套筒	P46	<b>H.C.B-A1494</b> MAN FLYWHEEL ROTATING TOOL (WITH 1 GEAR) (Dr. 1/2") MAN 飛輪轉動工具(1齒)(Dr. 1/2")	P51
<b>H.C.B-A2212</b> TRUCK INJECTOR SOCKET KIT (4 PCS) 卡車噴油嘴套筒組(4 PCS)	P46	<b>H.C.B-A1557-50</b> BENZ ACTROS AXLE BOLT SOCKET (32 EPL, L: 50 mm) BENZ ACTROS 輪軸螺絲套筒(32 EPL, L: 50 mm)	P52
<b>H.C.B-A2222</b> DIESEL INJECTOR SOCKET KIT(4 PCS) 柴油噴油嘴套筒組(4 PCS)	P47	<b>H.C.B-A1557-90</b> BENZ ACTROS AXLE BOLT SOCKET (32 EPL, L: 90 mm) BENZ ACTROS 輪軸螺絲套筒(32 EPL,L: 90 mm)	P52
<b>H.C.B-A1390</b> EUROPEAN TRUCK DISC BRAKE CALIPER SOCKET(Dr. 3/8", 11 TEETH) 歐系卡車碟煞卡鉗套筒(Dr. 3/8", 11 齒)	P47	<b>H.C.B-A2018-26</b> BENZ/HINO TRUCK OIL MIST SEPARATOR WRENCH (Dr. 1/2", 12 POINTS, 96 mm) BENZ/HINO 卡車油水分離器扳手(Dr. 1/2", 12角, 96 mm)	P52
<b>H.C.B-A1403</b> BPW (12 TONS) TRAILER OIL SEAL INSTALLER BPW 12噸板車輪軸油封安裝器	P48	<b>H.C.B-A1562</b> DAF (CF) 85 COMPRESSOR REAR SEAT BEARING FIX BOLT SOCKET (11 RIBS) DAF (CF) 85 空壓機後座培林固定螺絲套筒(11齒)	P53
<b>H.C.B-A1434</b> LIEBHERR CRANE WHEEL SOCKET (Dr. 1") LIEBHERR 吊車輪軸蓋套筒(Dr. 1")	P48	<b>H.C.B-A1572</b> DAF (CF) DRIVE AXLE NUT SOCKET (EURO 5) (Dr. 1", 6 POINTS, 120 mm) DAF (CF)5期環保帶動軸螺帽套筒(Dr. 1", 6 角, 120 mm)	P53
<b>H.C.B-A1404</b> ROR TRAILER REAR WHEEL NUT SOCKET (Dr. 1", 8 POINT,83 mm, 3 1/4") (DRUM BRAKE) ROR 板車輪軸螺帽套筒(鼓式剎車) (Dr. 1" 8角, 83 mm, 3 1/4")	P48	<b>H.C.B-A1581</b> VOLVO (FM) CRANKSHAFT REAR OIL SEAL INSTALLER VOLVO (FM) 曲軸後油封安裝器	P53
 <b>H.C.B-B1488-120</b> ROR REAR WHEEL HUB NUT SOCKET (DISC BRAKE) (Dr. 1", 8 POINT, 120 mm) ROR 板車輪軸螺帽套筒(碟式煞車) (Dr. 1", 8 角, 120 mm)	P49	<b>H.C.B-A1582</b> VOLVO (FM) TRANSMISSION OIL TUBE NUT WRENCH (74 mm) VOLVO (FM)變速箱油管螺帽扳手(74 mm)	P53
<b>H.C.B-A1482</b> BENZ REAR AXLE NUT SOCKET (Dr. 3/4", 105-125 mm) BENZ 後輪軸螺帽套筒 (Dr. 3/4", 105-125 mm)	P50	 <b>H.C.B-A1610</b> VOLVO (FM) CRANKSHAFT FRONT OIL SEAL INSTALLER TOOL VOLVO (FM)曲軸前油封安裝工具	P54
<b>H.C.B-A1483</b> BENZ & MAN REAR AXLE NUT SOCKET (Dr. 3/4", 80-95 mm) BENZ & MAN 後輪軸螺帽套筒(Dr. 3/4", 80-95 mm)	P50	 <b>H.C.B-A1661</b> BENZ TRUCK 2636 REAR WHEEL AXLE NUT SOCKET (Dr. 3/4") BENZ 卡車2636 後輪雙軸螺帽套筒 (Dr. 3/4")	P54
 <b>H.C.B-A1448</b> SAF BUSH REMOVAL/ INSTALLATION TOOL KIT SAF 鐵套拆裝工具組	P50	<b>H.C.B-A1177</b> TOYOTA ZACE/ DAF BALL JOINT EXTRACTOR (32 mm) TOYOTA瑞獅/ DAF方向機主機球頭拔卸器(32 mm)	P54
<b>H.C.B-A1466</b> SAF WHEEL SHAFT COVER SOCKET (Dr. 1",8 POINTS,130 mm) SAF 輪軸蓋拆裝套筒 (Dr. 1", 8角, 130 mm)	P50	<b>H.C.B-A1569</b> SCANIA LIFT AXLE LUG PIN REMOVAL TOOL KIT (W/HYDRAULIC CYLINDER) SCANIA 舉升軸吊耳插銷拆卸工具組(油壓)	P55
<b>H.C.B-A1492</b> BENZ & MAN FLYWHEEL ROTATING TOOL (WITH 2 GEARS) (Dr. 1/2") BENZ & MAN卡車飛輪轉動工具(2齒)(Dr. 1/2")	P51		

**Japanese Truck Repair Tool**  
日系卡車修護工具

**H.C.B-A1127** ..... P56  
FUSO REAR WHEEL NUT SOCKET  
(8 POINTS, 120 mm)  
FUSO 卡車後輪螺帽拆裝套筒(8角, 120 mm)

**H.C.B-A1184** ..... P56  
HINO CRANKSHAFT REAR OIL SEAL  
INSTALLER(JO8C)  
HINO 卡車曲軸後油封安裝器(JO8C)

**H.C.B-B1184** ..... P56  
HINO CRANKSHAFT FRONT OIL SEAL INSTALLER  
HINO 卡車曲軸前油封安裝器

**H.C.B-C1184** ..... P57  
HINO CRANKSHAFT FRONT OIL SEAL  
INSTALLER (JO8C)  
HINO 卡車曲軸前油封安裝器(JO8C)

**H.C.B-A1178** ..... P57  
FUSO/HINO PROFIA 700 STEERING MECHANISM  
OIL SEAL SOCKET (Dr. 1/2")  
FUSO/HINO 大將700 卡車方向機油封套筒(Dr. 1/2")

**H.C.B-B1178** ..... P57  
FUSO STEERING MECHANISM OIL SEAL SOCKET  
(Dr. 1/2") (UNDER 15 TONS)  
FUSO 方向機油封套筒 (Dr. 1/2")(15噸以下)

 **H.C.B-C1178** ..... P58  
FUSO CANTER (3.5 TONS) STEERING GEAR OIL  
SEAL SOCKET (Dr. 1/2") (EURO 4)  
FUSO 堅達(3.5噸)方向機主機油封螺母套筒  
(Dr. 1/2") (四期環保)

**H.C.B-A1270** ..... P58  
HINO STEERING MECHANISM OIL SEAL  
SOCKET (Dr. 1/2")  
HINO 方向機油封套筒 (Dr. 1/2")

**H.C.B-A1210** ..... P58  
MITSUBISHI CANTER / FUSO AXLE BALL JOINT  
PULLER  
三菱堅達/FUSO仰角球接頭拆卸器

**H.C.B-A1248** ..... P58  
MITSUBISHI DELICA 2500 c.c. WHEEL NUT  
SOCKET (Dr. 1/2")  
得利卡2500 c.c. 輪軸螺帽套筒 (Dr. 1/2")

**H.C.B-A1275** ..... P59  
HINO / ISUZU / FUSO / UD ANCHOR PIN  
REMOVER (HYDRAULIC)  
HINO / ISUZU / FUSO / UD 剎車來令片插銷拆卸器(油壓)

**H.C.B-A1286** ..... P59  
HINO 11.9 TONS REAR WHEEL AXLE NUT SOCKET  
(Dr. 3/4" , 8 POINTS, 105 mm)  
HINO 11.9噸後輪軸螺帽套筒(Dr. 3/4" , 8角, 105 mm)

**H.C.B-B1056** ..... P59  
ISUZU 3.5 TONS REAR WHEEL AXLE NUT SOCKET  
ISUZU 3.5 噸後輪軸螺帽套筒

**H.C.B-A1122** ..... P60  
ISUZU CRANKSHAFT OIL SEAL REPLACER  
ISUZU 曲軸油封更換器

**H.C.B-A1261** ..... P60  
ISUZU CRANKSHAFT REAR OIL SEAL  
INSTALLER (3.5 TONS)  
ISUZU 曲軸後油封安裝器(3.5噸)

**H.C.B-B1261** ..... P60  
ISUZU CRANKSHAFT FRONT OIL SEAL  
INSTALLER (3.5 TONS)  
ISUZU 曲軸前油封安裝器(3.5噸)

**H.C.B-A1351** ..... P61  
UD 350 (CK450) UD 380 (CK451) TRUCK  
CRANKSHAFT REAR OIL SEAL INSTALLER  
UD 350(CK450) UD 380 (CK451)卡車曲軸後油封安裝器

 **H.C.B-B1351** ..... P61  
UD 17 TONS (FE6) TRUCK CRANKSHAFT  
REAR OIL SEAL INSTALLATION TOOL KIT  
UD 17噸(FE6) 曲軸後油封安裝工具組

**H.C.B-A1066-5** ..... P61  
UNIVERSAL AXLE EXTRACTOR  
(FOR TRUCKS ONLY)  
萬用輪軸拆卸器(卡車專用)

**H.C.B-A1397** ..... P62  
UD TRUCK (CW520, CW530) CRANKSHAFT  
REAR OIL SEAL INSTALLER  
UD 卡車 (CW520,CW530) 曲軸後油封安裝器

**H.C.B-C1102** ..... P62  
JAPANESE TRUCK BALL JOINT REMOVER  
(39 mm) PAT. M 362085  
日系卡車球接頭拆卸器(39 mm)

**H.C.B-A1179** ..... P63  
PITMAN ARM PULLER (Dr. 3/4" , 62 mm)  
方向機搖臂拆卸器(Dr. 3/4" , 62 mm)

**H.C.B-A1180** ..... P63  
PITMAN ARM PULLER (Dr. 3/4" , 47mm)  
方向機搖臂拆卸器(Dr. 3/4" , 47 mm)

**H.C.B-B1181** ..... P63  
ISUZU, FUSO, TOYOTA SPRING PIN METAL BUSH  
REMOVAL/INSTALLATION TOOL KIT (HYDRAULIC)  
ISUZU, FUSO, TOYOTA 卡車彈簧銷拆裝工具組(油壓式)

**H.C.B-A1170** ..... P64  
TRUCK TORQUE-ROD BUSH REMOVAL/  
INSTALLATION TOOL KIT PAT. M307531  
卡車扭力桿鐵套拆裝工具組

**H.C.B-A1338** ..... P65  
TRUCK VALVE REMOVER / INSTALLER  
卡車汽門拆裝器

**H.C.B-A1415** ..... P65  
HINO #700 BRAKE ADJUSTMENT WRENCH  
HINO #700煞車調整扳手

 **H.C.B-B1415** ..... P65  
HINO #700 BRAKE ADJUSTMENT WRENCH  
HINO #700煞車調整扳手





**HWANG CHERNG BIN**  
Specialty Tools Inc.

SINCE 1990

**H.C.B-A1439** ..... P65  
JAPANESE TRUCK WHEEL NUT SOCKET  
日本卡車輪軸螺帽套筒

**H.C.B-A1472** ..... P66  
FUSO TRUCK TRANSMISSION/SHAFT SLEEVE  
PULLER SET  
FUSO 卡車變速箱/軸套拆卸組

**H.C.B-A1495-1** ..... P66  
ISUZU PETROL OIL MIST SEPARATE WRENCH  
(Dr. 1/2")  
ISUZU 汽油油水分离器扳手(Dr. 1/2")

**H.C.B-A1495-2** ..... P66  
ISUZU PETROL OIL MIST SEPARATE SOCKET  
(Dr.1/2")  
ISUZU 汽油油水分离器套筒 (Dr. 1/2")

 **H.C.B-C1491** ..... P67  
HINO (JO8C/JO8E) TRUCK INJECTION NOZZLE  
PULLER/ INJECTION NOZZLE SLEEVE  
REMOVAL/INSTALLATION TOOL KIT  
HINO (JO8C/JO8E) 噴油嘴拆卸器/噴油嘴銅套拆裝工具組

 **H.C.B-B1491** ..... P67  
HINO (JO8C/JO8E) TRUCK INJECTION NOZZLE  
SLEEVE REMOVAL/INSTALLATION TOOL KIT  
HINO (JO8C/JO8E) 噴油嘴銅套拆裝工具組

**H.C.B-A1491** ..... P67  
HINO (JO8C/JO8E) TRUCK INJECTION NOZZLE  
PULLER  
HINO (JO8C/JO8E) 卡車噴油嘴拆卸器

 **H.C.B-A1628** ..... P68  
FUSO CANTER FUEL FILTER WRENCH  
(EURO 5) (Dr. 1/2") (50 mm)  
FUSO 堅達柴油濾芯扳手(五期環保) (Dr. 1/2") (50 mm)

**H.C.B-A1520** ..... P68  
Dr. 1", COMBINATION BUDD WHEEL IMPACT SOCKET  
(1/2" x 13/16", 41x21 mm, 38x20 mm, 35x17 mm, 33 mm)  
(5 PCS)  
Dr. 1" 卡車輪胎套筒組(1/2"x 13/16", 41x21 mm, 38x20 mm,  
35x17 mm,33 mm)(5 PCS)

 **H.C.B-A2313** ..... P68  
Dr. 1" TRUCK WHEEL SOCKET (12PT) (41x21 mm)  
Dr. 1"卡車輪胎套筒(12PT)( 41x21 mm)

 **H.C.B-B2313** ..... P69  
Dr. 1/2" TRUCK WHEEL SOCKET (12PT) (41x21 mm)  
Dr. 1/2"卡車輪胎套筒(12PT) ( 41x21 mm)

**H.C.B-A1579** ..... P69  
HINO (E13C) CRANKSHAFT FRONT OIL SEAL  
INSTALLER (700)  
HINO (E13C) 曲軸前油封安裝工具組 (700 型)

**H.C.B-B1579** ..... P69  
HINO (E13C) CRANKSHAFT REAR OIL SEAL  
INSTALLER (700)  
HINO(E13C) 曲軸後油封安裝工具組(700 型)

 **H.C.B-C1579** ..... P70  
HINO(F20C)TRUCK CRANKSHAFT FRONT OIL  
SEAL INSTALLER (21 TONS)  
HINO(F20C) 曲軸前油封安裝器 (21 噸)

**H.C.B-A1586** ..... P70  
HINO 11 TONS WHEEL SPEED SENSOR  
REMOVAL/INSTALLATION TOOL KIT  
HINO 11噸輪速感應片拆裝工具

 **H.C.B-A1625** ..... P70  
HINO (P11C/K13C) CRANKSHAFT REAR OIL  
SEAL INSTALLATION TOOL KIT  
HINO (P11C/K13C) 曲軸後油封安裝工具組

 **H.C.B-A1635** ..... P71  
ISUZU 35 TONS (6WG1/6WA1) CRANKSHAFT  
FRONT OIL SEAL/FAN AXLE OIL SEAL INSTALLER  
ISUZU 35 噸 (6WG1/6WA1)  
曲軸前油封及風扇軸油封安裝工具

**H.C.B-A2018** ..... P71  
MITSUBISHI CANTER 3.5 TONS/FUSO OIL FILTER  
WRENCH (Dr. 1/2", 15 POINTS, 100 mm)  
三菱堅達3.5噸/FUSO機油芯扳手 (Dr. 1/2", 15角, 100 mm)

**H.C.B-A2018-1** ..... P71  
MITSUBISHI NEW CANTER 8.8 TONS OIL FILTER  
WRENCH (TURBO) (Dr. 1/2", 15 POINTS, 101mm)  
三菱新堅達8.8噸機油芯扳手(Dr. 1/2", 15角, 101 mm)

**H.C.B-A2018-2** ..... P72  
HINO 15 TONS OIL FILTER WRENCH  
(Dr. 1/2", 16 POINTS, 108 mm)  
HINO 15噸機油芯扳手(Dr. 1/2", 16角, 108 mm)

**H.C.B-A2018-5** ..... P72  
ISUZU ELF OIL FILTER WRENCH  
(Dr. 1/2", 15 POINTS, 89 mm)  
ISUZU一路發機油芯扳手(Dr. 1/2", 15角, 89 mm)

**H.C.B-A2018-11** ..... P72  
MITSUBISHI ALL NEW CANTER DIESEL FUEL  
FILTER WRENCH (Dr. 1/2", 16 POINTS, 107 mm)  
三菱新堅達柴油車燃油濾清器扳手(Dr. 1/2", 16角, 107 mm)

**H.C.B-A2018-12** ..... P72  
MITSUBISHI ALL NEW CANTER DIESEL OIL AND  
WATER SENSOR WRENCH (12 POINTS, 54 mm)  
三菱新堅達柴油車油水感應器扳手(12角, 54 mm)

**H.C.B-A2018-13** ..... P73  
HINO 17 TONS OIL FILTER WRENCH (EURO 4)  
(Dr. 1/2", 16 POINTS, 118 mm)  
HINO 17噸機油芯套扳手(四期環保)  
(Dr. 1/2", 16角, 118 mm)

**H.C.B-A2018-14** ..... P73  
MITSUBISHI VERYCA (1200 c.c.) OIL FILTER WRENCH  
(EURO 4) (14 POINTS, 66.5 mm)  
中華菱利(1200 c.c.)機油芯扳手(四期) (14角, 66.5 mm)

**H.C.B-A2018-17** ..... P73  
FUSO (6.5 / 6.8 / 7.7 TONS) TRUCK OIL FILTER  
WRENCH (Dr. 1/2", 16 POINTS, 106.5 mm)  
FUSO(6.5 / 6.8 /7.7噸)卡車機油芯扳手  
(Dr. 1/2", 16角, 106.5 mm)



**HWANG CHERNG BIN**  
Specialty Tools Inc.

**H.C.B-A2018-18** ..... P73  
**FUSO (10.5 ~ 17 TONS) TRUCK OIL FILTER  
WRENCH (Dr.1/2",15 POINTS, 119 mm)**  
FUSO(10.5 ~ 17噸)卡車機油芯扳手  
(Dr. 1/2", 15角, 119 mm)

**H.C.B-A2018-20** ..... P74  
**FUSO TRUCK OIL MIST SEPARATOR WRENCH  
(Dr. 1/2", 8 RIBS, 109 mm)**  
FUSO卡車油水分離器扳手 (Dr. 1/2", 8齒 · 109 mm)

**H.C.B-A2018-21** ..... P74  
**HINO TRUCK/ISUZU TRUCK 3.5 TONS (EURO 4) OIL  
MIST SEPARATOR WRENCH (Dr. 1/2", 8 RIBS, 107 mm)**  
HINO 卡車/ISUZU 3.5噸(四期環保車)油水分離器扳手  
(Dr. 1/2", 8齒 · 107 mm)

**H.C.B-A2018-22** ..... P74  
**ISUZU (4.9~7.9 TONS)TRUCK OIL FILTER  
WRENCH (Dr. 1/2", 15POINTS, 118 mm)**  
ISUZU (4.9~7.9噸)卡車機油芯扳手  
(Dr.1/2",15角,118 mm)

**H.C.B-A2018-23** ..... P74  
**HINO(EURO 4) (3.5 ~7.4 TONS)TRUCK OIL FILTER  
WRENCH (Dr. 1/2", 15 POINTS, 101.5 mm)**  
HINO (四期) (3.5 ~7.4 噸)卡車機油芯扳手  
(Dr. 1/2", 15 角, 101.5 mm)

**H.C.B-A2018-24** ..... P75  
**FUSO (6D16) MEDIUM-SIZED TRUCK OIL FILTER  
WRENCH (Dr. 1/2", 16 POINTS, 123 mm)**  
FUSO (6D16) 中型卡車機油芯扳手(Dr. 1/2", 16 角, 123 mm)

**H.C.B-A2018-25** ..... P75  
**FUSO (6D16) 11 TONS REMOVAL TOOL FOR FUEL  
FILTER(Dr. 1/2", 15 POINTS · 93 mm)**  
FUSO (6D16) 11 噸柴油濾芯扳手(Dr. 1/2", 15 角 · 93 mm)

**H.C.B-A2130** ..... P75  
**MITSUBISHI CANTER DIESEL OIL FILTER  
REMOVER / INSTALLER**  
三菱堅達柴油車機油芯拆裝工具





**HWANG CHERNG BIN**  
Specialty Tools Inc.

## General Truck Repair Tool 通用卡車修護工具

**H.C.B-A1102** ..... P76  
TRUCK BALL JOINT REMOVER (39 mm)  
**PAT. M 362085**  
卡車球接頭拆卸器(39 mm)

**H.C.B-A1112** ..... P76  
MEDIUM-SIZED WAGON BALL JOINT  
EXTRACTOR (32 mm) **PAT.**  
中型貨車球接頭拆卸器(32 mm)

**H.C.B-A1407** ..... P76  
UNIVERSAL TRUCK BALL JOINT REMOVER (32 mm)  
萬用球接頭拆卸器(32 mm)

**H.C.B-A1165** ..... P77  
PICKUP TRUCK & BUS BALL JOINT  
EXTRACTOR (30 mm)  
小型卡車、遊覽車球接頭拆卸器(30 mm)

**H.C.B-A1410** ..... P77  
UNIVERSAL TRUCK BALL JOINT REMOVER (39 mm)  
**PAT.438423**  
萬用球接頭拆卸器(39 mm)

**H.C.B-C1410** ..... P78  
UNIVERSAL TRUCK BALL JOINT REMOVER (39 mm)  
(W/HYDRAULIC SPINDLE) **PAT.438423**  
萬用球接頭拆卸器(39 mm)(油壓桿)

**H.C.B-A1082-1** ..... P79  
UNIVERSAL BALL JOINT SEPARATOR  
(SCREW REPLACEABLE) (24 mm) **PAT. 208928**  
萬用球接頭拆卸組(可替換螺絲)(24 mm)

**H.C.B-B1182** ..... P79  
UNIVERSAL TRUCK BALL JOINT PULLER (REPLACEABLE)  
(24 mm & 32 mm) - IMPROVEMENT **PAT. M 384746**  
萬用卡車可換式球接頭拆卸器(24 mm & 32 mm)-改良型

**H.C.B-A1225** ..... P79  
TRUCK BALL JOINT PULLER (32 mm) (HYDRAULIC)  
卡車球接頭拆卸器(32 mm)(油壓式)

**H.C.B-A1226** ..... P79  
TRUCK BALL JOINT PULLER (39 mm) (HYDRAULIC)  
卡車球接頭拆卸器(39 mm)(油壓式)

**H.C.B-A1009** ..... P80  
AUTOMATIC TRANSMISSION CLUTCH  
SPRING COMPRESSOR  
自動變速箱離合器壓板拆裝工具

**H.C.B-A1120** ..... P80  
TRUCK TRANSMISSION BEARING PULLER  
卡車變速箱培林拆卸組

**H.C.B-A1120-308** ..... P81  
ISUZU TRUCK TRANSMISSION BEARING  
PULLER (OPTIONAL ACCESSORY)  
ISUZU 卡車變速箱培林拆卸組(選購配件)

**H.C.B-A1120-309** ..... P81  
HINO KUOZUI 15 TONS TRUCK TRANSMISSION  
BEARING PULLER (OPTIONAL ACCESSORY)  
HINO 國瑞15噸卡車變速箱培林拆卸組(選購配件)

**H.C.B-A1120-310** ..... P81  
SCANIA TRUCK TRANSMISSION BEARING  
PULLER (OPTIONAL ACCESSORY)  
SCANIA 卡車變速箱培林拆卸組(選購配件)

**H.C.B-B1120** ..... P82  
TRUCK TRANSMISSION BEARING PULLER  
中型貨車變速箱培林拆卸器

**H.C.B-B1120-A** ..... P82  
FUSO TRUCK LAY SHAFT BEARING PULLER  
FUSO 卡車副軸培林拆卸組

**H.C.B-B1120-B** ..... P82  
ISUZU 6.8 TONS TRUCK MAIN SHAFT  
BEARING PULLER  
ISUZU 6.8 噸卡車主軸培林拆卸組

**H.C.B-B1120-C** ..... P82  
ISUZU MEDIUM TRUCK BEARING PULLER  
ISUZU 中型卡車培林拆卸組

**H.C.B-A1183** ..... P83  
TRUCK THREAD CORRECTOR  
卡車可換式螺紋修正器

**H.C.B-A1187** ..... P83  
PNEUMATIC BRAKE LINING SHOE LOADER  
卡車剎車來令拆裝機(氣壓式)

**H.C.B-C1181** ..... P84  
TRUCK SPRING PIN METAL BUSH REMOVAL /  
INSTALLATION TOOL KIT (HYDRAULIC)  
卡車彈簧鋼套/插銷拆裝工具組(油壓式)

**H.C.B-D1181** ..... P84  
TRUCK SPRING PIN METAL BUSH REMOVAL /  
INSTALLATION TOOL KIT  
(17 TONS HYDRAULIC CYLINDER)  
卡車彈簧鋼拆裝工具組(17噸油壓式)

**H.C.B-E1181** ..... P84  
TRUCK SPRING PIN METAL BUSH REMOVAL/  
INSTALLATION TOOL KIT  
卡車彈簧鋼拆裝工具組



**H.C.B-F1181** ..... P85  
TRUCK SPRING PIN METAL BUSH REMOVAL /  
INSTALLATION TOOL KIT  
(17 TONS HYDRAULIC CYLINDER)  
卡車彈簧鋼拆裝工具組(17噸油壓式)



**H.C.B-A1665** ..... P85  
UNIVERSAL HYDRAULIC PRESSURE KIT  
通用油壓組

**H.C.B-A1191** ..... P85  
UNIVERSAL BALL JOINT SEPERATOR (22 mm)  
萬用球接頭拆裝工具組(22 mm)(橫拉桿)

**H.C.B-A1222** ..... P86  
UNIVERSAL CRANKSHAFT PULLEY EXTRACTOR  
萬用卡車曲軸皮帶盤拆卸器

**H.C.B-A1279** ..... P86  
UNIVERSAL AXLE NUT REMOVAL/INSTALLATION  
TOOL KIT  
萬用型輪軸螺帽拆裝組

**H.C.B-B1391** ..... P87  
UNIVERSAL TRUCK WHEEL HUB EXTRACTOR  
萬用卡車輪軸HUB拆卸器



**HWANG CHERNG BIN**  
Specialty Tools Inc.

<b>H.C.B-C1391</b> UNIVERSAL TRUCK WHEEL HUB EXTRACTOR 萬用卡車輪軸HUB拆卸器	P87	<b>H.C.B-A2045</b> 1.5 TONS TRUCK TRANSMISSION JACK 1.5 噸卡車變速箱千斤頂	P93
<b>H.C.B-A1256</b> PITMAN ARM PULLER (32 mm) 大車橫拉桿球頭拆卸器(32 mm)	P88	<b>H.C.B-A2165</b> HYDRAULIC BEARING PULLER (8 TONS) 油壓式培林拔輪器(8噸)	P94
<b>H.C.B-A1383</b> ELECTRICAL BRAKE LINING SHOE LOADER <b>PAT. 409117</b> 電動鉗釘機	P88	<b>H.C.B-B2165</b> HYDRAULIC BEARING PULLER (8 TONS) 油壓式培林拔輪器(8噸)	P94
<b>H.C.B-A1054-2</b> UNIVERSAL SEPARATOR (R2) <b>PAT. 172921</b> 萬用拔卸器(R2)	P88	<b>H.C.B-C2165</b> HYDRAULIC BEARING PULLER (12 TONS) 油壓式培林拔輪器(12噸)	P94
<b>H.C.B-A1054-4</b> STEERING WHEEL PULLER BOLT (EXTENDED) 方向盤拔卸器螺絲(加長型)	P88	<b>H.C.B-D2165</b> HYDRAULIC BEARING PULLER (4 TONS) 油壓式培林拔卸器(4噸)	P94
<b>H.C.B-A1287</b> DAEWOO TRUCK WHEEL AXLE NUT SOCKET (Dr. 3/4", 6 POINTS, 116 mm) 大宇卡車輪軸螺帽套筒(Dr. 3/4", 6角, 116 mm)	P89	<b>H.C.B-B2126</b> 20 TONS AIR HYDRAULIC BOTTLE JACK 20 噸氣動油壓千斤頂	P95
<b>H.C.B-A2018-27</b> HYUNDAI PORTER/KIA MOTOR TRUCK OIL FILTER WRENCH (Dr. 1/2", 15 POINTS, 91.7 mm) HYUNDAI PORTER/KIA MOTOR 卡車機油芯扳手 (Dr. 1/2", 15角, 91.7 mm)	P89	<b>H.C.B-B2127</b> 30 TONS AIR HYDRAULIC BOTTLE JACK 30 噸氣動油壓千斤頂	P95
<b>H.C.B-A2013</b> TRANSMISSION FLOOR JACK (1 TON) 臥式變速箱千斤頂(1噸)	P89	<b>H.C.B-A2146</b> PNEUMATIC GREASE PUMP (20 L) 氣動黃油機(20 升)	P95
<b>H.C.B-F1168</b> UNIVERSAL BALL JOINT SERVICE KIT <b>PAT M.333280</b> 專利型萬象十字接頭拆卸器	P90	<b>H.C.B-A2160</b> WASTE OIL DRAINER (80 L) 廢油桶(80升)	P96
<b>H.C.B-A2019</b> 3 TONS FOUR WHEELS HYDRAULIC FLOOR JACK 3 噸油壓四輪千斤頂	P90	<b>H.C.B-B2160</b> 50 L WASTE OIL DRAINER (MANUAL) 手動升降式佇油機(50升)	P96
<b>H.C.B-A2101</b> UNIVERSAL ADJUSTABLE WHEEL BEARING LOCK NUT WRENCH 後軸螺帽拆卸器(萬用型)	P91	<b>H.C.B-A2203</b> PNEUMATIC FLUID EXTRACTOR (8.5 L) 氣動油油機(8.5升)	P97
<b>H.C.B-A2102</b> HYDRAULIC WHEEL DOLLY 大車輪胎搬運車	P91	<b>H.C.B-A2204</b> PNEUMATIC OIL & LIQUID DISPENSER (6000 c.c.) 吸排兩用液體分裝機(6000 c.c.)	P97
 <b>H.C.B-B2102</b> HYDRAULIC WHEEL DOLLY 大車輪胎搬運車	P91	<b>H.C.B-A2205</b> BASIC BRAKE OIL EXTRACTOR (2000 c.c.) 專業剎車油吸取機(2000 c.c.)	P98
<b>H.C.B-A1015</b> BLIND HOLE BEARING PULLER 隱蔽型培林拔卸組	P92	<b>H.C.B-A2206</b> BRAKE OIL FILLER (1000 c.c.) 剎車油補充油瓶(1000 c.c.)	P98
<b>H.C.B-B2115</b> BLIND HOLE BEARING PULLER 隱蔽型培林拔卸組	P92	<b>H.C.B-A1065</b> WAGON SUPPORTER 貨車專用安全頂架(配合平板頂車機使用)	P99
 <b>H.C.B-A1655</b> UNIVERSAL BEARING EXTRACTOR 萬用培林拔卸器	P93	<b>H.C.B-A2147</b> GREASE FILLER FOR PAI (20 L) 鋁合金手壓式培林注油機(20升)	P99
		<b>H.C.B-A2148</b> TRACK BEARING PACKER (FOR TRUCK) 鋁合金氣壓式培林注油機	P99
		<b>H.C.B-A2157</b> TRUCK JACK STAND 15,000 LBS 卡車千斤頂 15,000磅	P100





**HWANG CHERNG BIN**  
Specialty Tools Inc.

**H.C.B-A2158** ..... P100  
TRUCK JACK STAND 15,000 LBS  
卡車千斤頂 15,000磅

**H.C.B-B2158** ..... P101  
TRUCK JACK STAND 33,000 LBS  
卡車千斤頂 33,000磅

**H.C.B-A2226** ..... P101  
JACK STAND (18")  
貨車頂車架(18")

**H.C.B-B2226** ..... P101  
JACK STAND (24")  
貨車頂車架(24")

**H.C.B-C2226** ..... P101  
JACK STAND (28")  
貨車頂車架(28")

**H.C.B-A2009** ..... P102  
CLUTCH ALIGNMENT TOOL (IRON)  
離合器對孔校正器(鐵)

**H.C.B-A2021** ..... P102  
SOCKET TOOL KIT (34 PCS)  
星型中空,E型綜合套筒組(34 PCS)

**H.C.B-A2022** ..... P102  
18 PCS IMPACT HEXAGON & TX-STAR WRENCH KIT  
6角,星型凸套筒組(18 PCS)

**H.C.B-A2086** ..... P103  
160 PCS COMPREHENSIVE TOOL KIT  
160 PCS專業級套筒組

**H.C.B-A2145** ..... P103  
94 PCS (Dr. 1/4" & 1/2" ) TOOL KIT  
94 PCS (Dr. 1/4" & 1/2") 套筒組

**H.C.B-A2166** ..... P104  
16 PCS (Dr. 3/4" & 1") SQ. DRIVE INSERT BIT  
SOCKET KIT  
16 PCS 套筒組 (Dr. 3/4" & 1")

**H.C.B-A2168** ..... P104  
9 PCS STAR-E SOCKET KIT  
(E10/E11/E12/E14/E16/E18/E20/E22/E24)  
9 PCS E型套筒組

**H.C.B-A2209** ..... P104  
DIESEL INJECTOR SEAT CUTTER KIT  
柴油噴油嘴座清除器

**H.C.B-A2107** ..... P105  
EXTRA LONG OFFSET BOX WRENCH KIT (8 PCS)  
加長型梅花扳手組(8 PCS)

**H.C.B-B2107** ..... P105  
EXTRA LONG OFFSET BOX WRENCH KIT (6 PCS)  
(10 x 12,12 x 14, 13 x 15,16 x 18,17 x 19, 22 x 24 mm)  
加長平型梅花扳手組 (6PCS)  
(10 x 12,12 x 14, 13 x 15,16 x 18,17 x 19, 22 x 24 mm)

**H.C.B-A2177** ..... P105  
5 PCS HALF-MOON RING WRENCH  
5 PCS 扳手(半月型)

**H.C.B-B2192** ..... P106  
OIL DRAIN REPAIR KIT  
油底殼螺絲更換組



**H.C.B-A1641** ..... P106  
UNIVERSAL LOCKING RING TOOL **PAT.**  
萬能扣環鉗PAT.

**H.C.B-A2170** ..... P107  
DIESEL ENGINE COMPRESSION TESTER SET  
柴油引擎汽缸壓力測試工具組

**H.C.B-A1320** ..... P108  
SPECIAL SOCKET FOR TRUCK (Dr. 3/4", 6 POINTS)  
卡車特殊套筒(Dr. 3/4", 6角)

**H.C.B-B1320** ..... P108  
SPECIAL SOCKET FOR TRUCK (Dr. 1", 6 POINTS)  
卡車特殊套筒(Dr. 1", 6角)

**H.C.B-B1320-7090** ..... P109  
SPECIAL SOCKET FOR TRUCK (Dr. 1", 70 mm, L: 90 mm )  
卡車特殊套筒(Dr. 1" · 70 mm · 長度 : 90 mm )

**H.C.B-A1488** ..... P109  
SPECIAL SOCKET FOR TRUCK (Dr. 3/4", 8 POINTS)  
卡車輪軸螺帽套筒(Dr. 3/4" · 8角)

**H.C.B-B1488** ..... P109  
SPECIAL SOCKET FOR TRUCK (Dr. 1", 8 POINTS)  
卡車輪軸螺帽套筒(Dr. 1" · 8角)

**H.C.B-A1592** ..... P110  
SPECIAL SOCKET FOR TRUCK  
(Dr. 1", 12 POINTS, L: 90 mm )  
卡車特殊套筒(Dr. 1" · 12 角 · L: 90 mm)

**H.C.B-A1336** ..... P110  
MANUAL LINING PULLER KIT  
手動汽缸套拔卸組

**H.C.B-A1337** ..... P111  
TRUCK K/D RACK - MANUAL **PAT.I 380921**  
手動卡車多功能拆裝架

**H.C.B-B1337** ..... P111  
TRUCK K/D RACK - ELECTRICAL **PAT.I 380921**  
電動卡車多功能拆裝架

**H.C.B-C1337** ..... P112  
TRANSMISSION FIXING BASE  
卡車變速箱固定座

**H.C.B-D1337** ..... P112  
DIFFERENTIAL FIXING BASE  
卡車差速器固定座



**H.C.B-E1337** ..... P112  
CUMINS ENGINE FIXING BASE (EURO 4)  
康明斯引擎固定架(四期環保)

**H.C.B-A1339** ..... P112  
TRUCK KING PIN PRESS (30 TONS)  
**DE. PAT.M459081**  
大王銷拆卸機(30噸)

**H.C.B-B1339** ..... P113  
TRUCK KING PIN PRESS (75 TONS)  
**DE. PAT.M459081**  
大王銷拆卸機(75噸)





**HWANG CHERNG BIN**  
Specialty Tools Inc.

**H.C.B-A1435** ..... P113  
KENWORTH TRUCK REAR AXLE NUT  
SOCKET (SW 4", 6 POINTS, Dr. 3/4")  
KENWORTH 卡車後輪軸螺帽套筒 (SW 4" · 6角 · Dr.3/4")

**H.C.B-C1339** ..... P114  
TRUCK KING PIN PRESS (75 TONS)  
**DE. PAT.M459081**  
大王銷拆卸機(75噸)

**H.C.B-A2050** ..... P114  
CAST STEEL SWIVEL-BASE VISE (6")  
老虎鉗(6")

**H.C.B-A2050-1** ..... P114  
CAST STEEL SWIVEL-BASE VISE (8")  
老虎鉗(8")

**H.C.B-A2050-2** ..... P114  
CAST STEEL SWIVEL-BASE VISE (10")  
老虎鉗(10")

**H.C.B-B2050** ..... P114  
CAST IRON VISE (6")  
老虎鉗(6")

**H.C.B-A2094** ..... P114  
TWO WAY OIL FILTER WRENCH (60~80 mm)  
二爪正反轉機油芯扳手(60~80 mm)

**H.C.B-B2094** ..... P115  
TWO WAY OIL FILTER WRENCH (80~110 mm)  
二爪正反轉機油芯扳手(80~110 mm)

**H.C.B-D2094** ..... P115  
TWO WAY OIL FILTER WRENCH (104~150 mm)  
二爪正反轉機油芯扳手(104~150 mm)

**H.C.B-A2121** ..... P115  
PORTABLE POWER STATION (SEDAN)  
電霸(一般轎車用)

**H.C.B-B2121** ..... P115  
PORTABLE POWER STATION (FOR SEDAN)  
電霸(汽油車, 柴油車用)

**H.C.B-C2121** ..... P116  
PORTABLE POWER STATION (FOR 230V/50Hz)  
電霸(230V/50Hz)

**H.C.B-D2121** ..... P116  
PORTABLE POWER STATION (FOR VEHICLE)  
電霸(電力士)



**H.C.B-B2294** ..... P116  
LED WORK LIGHT  
LED工作燈



**H.C.B-C2294** ..... P117  
LED POWER PACK LIGHT  
LED行動電源工作燈



**H.C.B-C2195** ..... P117  
ANGLE ADJUSTABLE 30 PCS LED WORKING  
LIGHT AC/DC RECHARGEABLE BATTERY  
LED工作燈(附磁鐵)

**H.C.B-A2061** ..... P118  
HEIGHTENED MANUAL HYDRAULIC PRESS (15 TONS)  
加高型手動油壓床(15噸)

**H.C.B-A2197** ..... P118  
HEAVY DUTY OIL FILTER CHAIN WRENCH (350 mm)  
鏈條式機油濾芯扳手(350 mm)

**H.C.B-B2197** ..... P118  
HEAVY DUTY OIL FILTER CHAIN WRENCH (520 mm)  
鏈條式機油濾芯扳手(520 mm)

**H.C.B-A2128** ..... P119  
AIR HOSE REEL (10 METERS)  
捲式風管(10米)

**H.C.B-B2128** ..... P119  
CORD REEL  
捲式三插座

**H.C.B-C2128** ..... P119  
CORD REEL+110V WORK LIGHT  
捲式三插座+日光燈(110V)

**H.C.B-D2128** ..... P120  
WATER HOSE REEL (8 METERS)  
水管捲揚器(8米)

**H.C.B-A1412** ..... P120  
TRUCK RADIATOR PRESSURE TEST KIT (9 PCS)  
卡車水箱測漏組(9PCS)

**H.C.B-A3005** ..... P121  
10 TONS TWO SPEEDS DYNAMIC POWER KIT  
10噸雙段油壓鉸金組

**H.C.B-A6001** ..... P121  
HYDRAULIC ELEVATOR CART (300 KGS)  
油壓升降推車(300公斤)

**H.C.B-A1497** ..... P121  
ALUM-A-STACK HYDRAULIC RAM KIT  
卡車堆疊式油壓組

**H.C.B-A1481** ..... P122  
VOLVO /HINO REMOVAL TOOL FOR OIL FILTER  
(Dr. 1/2") (100-110 mm)  
VOLVO /HINO 機油芯/油水分離器濾芯扳手  
(Dr. 1/2") (100-110 mm)

**H.C.B-B1481** ..... P122  
FUSO (10.5-17) TONS REMOVAL TOOL FOR OIL FILTER  
(Dr. 1/2") (110-125 mm)  
FUSO (10.5-17) 噸機油濾芯/油水分離器濾芯扳手  
(Dr. 1/2") (110-125 mm)

**H.C.B-C1481** ..... P122  
DAF/MAN/SCANIA REMOVAL TOOL FOR AIR DRYER  
FILTER (Dr. 1/2") (125-140 mm)  
DAF/MAN/SCANIA 四向閥乾燥濾芯扳手  
(Dr. 1/2") (125-140 mm)

**H.C.B-D1481** ..... P122  
SCANIA REMOVAL TOOL FOR FUEL FILTER  
(Dr. 1/2") (70-80 mm)  
SCANIA柴油濾芯扳手(Dr. 1/2") (70- 80 mm)

**H.C.B-E1481** ..... P122  
TRUCK REMOVAL TOOL FOR FUEL FILTER/OIL  
FILTER (80-90 mm)  
卡車柴油/機油濾芯扳手(80-90 mm)

**H.C.B-F1481** ..... P122  
EUROPEAN/JAPANESE TRUCK REMOVAL TOOL  
FOR FUEL FILTER/OIL FILTER (90-100 mm)  
歐/日系卡車柴油/機油濾芯扳手(90-100 mm)





**HWANG CHERNG BIN**  
Specialty Tools Inc.

**H.C.B-A1502** ..... P123  
20 TON AIR/HYDRAULIC FLOOR JACK - LOW PROFILE  
20 TON 氣動/油壓千斤頂(超低型)

**H.C.B-B1502** ..... P124  
20 TON AIR/HYDRAULIC TRUCK JACK-LOW TYPE  
20 TON 氣動/油壓千斤頂(超低型)

**H.C.B-C1502** ..... P124  
50 TON AIR/HYDRAULIC JACK  
50 TON 氣動/油壓千斤頂

**H.C.B-A1538** ..... P125  
EXTRA LONG HEXAGON IMPACT WHEEL NUTS  
SOCKET (Dr. 3/4", 24/27/30/32/33/36 mm, L: 400 mm)  
氣動長套筒(Dr. 3/4", 24/27/30/32/33/36 mm, L: 400 mm)

**H.C.B-A1560** ..... P125  
SCANIA 113(320) TRUCK FRONT WHEEL AXLE  
BEARING PULLER TOOL  
SCANIA 113(320) 卡車前輪軸培林拔卸器

**H.C.B-B1560** ..... P125  
TRUCK FRONT WHEEL AXLE BEARING PULLER  
TOOL (JAPANESE TRUCK)  
卡車前輪軸培林拔卸器 (日系車種)

**H.C.B-C1560** ..... P126  
TRUCK FRONT WHEEL AXLE BEARING PULLER  
TOOL (SCANIA/JAPANESE TRUCK)  
卡車前輪軸培林拔卸器 (SCANIA/日系車種)

**H.C.B-D1560** ..... P126  
TRUCK REAR WHEEL AXLE BEARING PULLER  
(JAPANESE TRUCK)  
卡車後輪軸培林拔卸器 (日系車種)

 **H.C.B-E1560** ..... P127  
SCANIA (113/114), MAN (410/414) TRUCK  
DIFFERENTIAL BEARING EXTRACTOR  
SCANIA (113/114), MAN (410/414) 卡車差速器培林拆卸器

**H.C.B-A2258** ..... P127  
TOE JACK  
L型油壓千斤頂

**H.C.B-A2273** ..... P128  
TRUCK CLUTCH AND FLYWHEEL JACK-  
LOW CLEARANCE  
卡車離合器/飛輪千斤頂

**H.C.B-A2280** ..... P128  
UNIVERSAL JOINT (Dr. 1")  
1"萬向轉接頭

**H.C.B-A2281** ..... P128  
Dr. 3/4" IMPACT SOCKET SET (17 PCS)  
(19/21/22/24/27/30/32/33/34/35/36/38/40/41/46/50/55 mm)  
Dr.3/4" 氣動套筒組 (17 PCS) (19/21/22/24/27/30/  
32/33/34/35/36/38/40/41/46/50/55 mm)

**H.C.B-A2282** ..... P129  
TRUCK BRAKE SPOONS (2 PCS)  
卡車剎車調整扳手(2 PCS)

 **H.C.B-C2297** ..... P129  
DIESEL/PETROL FUEL SYRINGE(1.5 L)  
柴/汽油真空抽取注射器 (1.5 升)

 **H.C.B-A2299** ..... P129  
3 FUNCTION TIRE PRESSURE GAUGE (FOR TRUCK)  
三用胎壓量錶(卡車)

 **H.C.B-A2300** ..... P130  
FLEXIBLE CROW'S FOOT SOCKET  
WRENCH SET (12 PCS)  
搖頭鴨掌扳手組 (12 PCS)

 **H.C.B-A2301** ..... P130  
75° BOX END & FLEXIBLE GEAR RATCHET WRENCH  
WITH GO-THROUGH SOCKET SET (17 PCS)  
穿透式套筒組 (17 PCS)

 **H.C.B-A2302** ..... P131  
DOUBLE FLEXIBLE RATCHET FLARE NUT WRENCH  
(10 x 12 /13 x 14/15 x 17 mm) (3 PCS)  
雙搖頭開口油管扳手  
(10 x 12 /13 x 14/15 x 17 mm)(3 PCS)

 **H.C.B-A2306** ..... P131  
DR. 3/4" TORQUE WRENCH (200-1000 N.M)  
DR. 3/4" 扭力扳手 (200-1000牛頓米)

 **H.C.B-A2307** ..... P132  
RATCHET EXHAUST PIPE CUTTER  
排氣管切管器

 **H.C.B-A2309** ..... P132  
3 L TRUCK/ TRAILER WHEEL AXLE OIL DRAIN  
3 L卡車/拖車輪軸油盤

 **H.C.B-A2310** ..... P132  
OIL DRAIN PAN  
油盤

**Air Power Tool**  
氣動修護工具

**H.C.B-A2005** ..... P133  
1/2" AIR IMPACT WRENCH  
1/2" 氣動扳手(下排式)

**H.C.B-A2005-1** ..... P133  
1/2" AIR IMPACT WRENCH (WITH 10 PCS SOCKET)  
1/2" 氣動扳手(下排式, 含套筒)

**H.C.B-B2025** ..... P133  
3/8" AIR MINI RATCHET WRENCH  
3分氣動棘輪扳手

**H.C.B-A2034** ..... P134  
1/4" 90° AIR STUBBY AIR RATCHET WRENCH  
1/4" 90° 氣動扳手

**H.C.B-A2046** ..... P134  
1/2" 90° STUBBY AIR RATCHET WRENCH  
1/2" 90° 氣動扳手

**H.C.B-A2047** ..... P134  
AIR DIE GRINDER  
氣動刻模機

**H.C.B-A2048** ..... P134  
16 PCS AIR DIE GRINDER KIT  
氣動刻模機組(16PCS)

**H.C.B-A2139** ..... P135  
1/2" MINI IMPACT WRENCH  
1/2" 輕型氣動扳手

**H.C.B-A2173** ..... P135  
1/2" 90° AIR RATCHET WRENCH  
1/2" 90° 氣動棘輪扳手

**H.C.B-A2200** ..... P135  
3/4" IMPACT WRENCH  
3/4" 氣動扳手

 **H.C.B-B2200** ..... P135  
3/4" ALUMINUM HOUSING IMPACT WRENCH  
3/4" 鋁合金氣動扳手

**H.C.B-A2285** ..... P136  
1/2" MINI COMPOSITE IMPACT WRENCH  
(JAMBO HAMMER)  
4分塑膠手柄迷你單環捶打式衝擊扳手

**H.C.B-A2286** ..... P136  
1/2" MINI COMPOSITE IMPACT WRENCH  
(JAMBO HAMMER)  
4分塑膠手柄雙環捶打式衝擊扳手

**H.C.B-B2286** ..... P136  
3/8" COMPOSITE IMPACT WRENCH  
(TWIN HAMMER) 475 NM  
3分塑膠手柄雙環捶打式衝擊扳手(扭力475牛頓米)

**H.C.B-A2287** ..... P136  
3/4" COMPOSITE IMPACT WRENCH  
(TWIN HAMMER)  
6分塑膠手柄雙環捶打式衝擊扳手

**H.C.B-A3036** ..... P137  
AIR HYDRAULIC PUMP(1600c.c.)(Dr.3/8"ADAPTOR)  
氣動幫浦(1600 c.c.)(3/8" 接頭)

**H.C.B-B3036** ..... P137  
AIR HYDRAULIC PUMP(1800 c.c.)  
氣動幫浦(1800 c.c.)

**H.C.B-C3036** ..... P137  
DOUBLE HOSE AIR HYDRAULIC PUMP(3800 c.c.)  
雙管幫浦(3800 c.c.)

**H.C.B-D3036** ..... P137  
AIR / HYDRAULIC PUMP (7600 c.c.)  
氣動/油壓幫浦(7600 c.c.)

**H.C.B-E3036** ..... P138  
AIR / HYDRAULIC FOOT PUMP (2000 c.c.)  
氣動/油壓幫浦(2000 c.c.)

 **H.C.B-F3036** ..... P138  
AIR/HYDRAULIC PUMP (WITHOUT HOSE) 6.2-6.8  
BAR AIR PRESSURE / PUMP230-245 BAR  
氣動/油壓幫浦(不含管)

**H.C.B-A2269** ..... P139  
1" SQ DR. HEAVY DUTY IMPACT WRENCH  
1" 氣動扳手

**H.C.B-A2270** ..... P139  
1" SQ DR. EXTRA HEAVY DUTY IMPACT WRENCH,  
LONG ANVIL  
1" 長軸氣動扳手





**HWANG CHERNG BIN**  
Specialty Tools Inc.

## General Repair Equipment

一般修護工具 修護設備

**H.C.B-A1073** ..... P140  
3-SHELF SERVICE CART (STAINLESS)  
三層不銹鋼工具車

**H.C.B-C1076** ..... P140  
11 DRAWER ROLLER CABINET  
11抽工具車

**H.C.B-A1135-R** ..... P141  
THE COMPACT TOOLBOX TROLLEY(RED)  
美式工具車

**H.C.B-A1541** ..... P141  
DIGITAL CALIPER  
極速卡尺

**H.C.B-A2001** ..... P141  
3-SHELF SERVICE CART  
3層工具車

**H.C.B-A2010** ..... P142  
FOUR-SHELF CART  
工具車(4層開放式附間隔塊)

**H.C.B-A2011** ..... P142  
TOOL BOX, 6 DRAWERS (MODEL 300)  
6抽工具車(300型)

**H.C.B-A2060** ..... P143  
TOOL BOX, 7 DRAWERS ROLLER CART  
(BALL BEARING SLIDE)  
7抽工具車

**H.C.B-B2060** ..... P143  
WALL CABINET  
(W: 660 mm x D: 305 mm x H: 600 mm)  
工具壁櫃(寬: 660 mm x 深: 305 mm x 高: 600 mm)

**H.C.B-C2060** ..... P143  
TOP TRAY  
上方膠盤

**H.C.B-D2060** ..... P143  
(18") SIDE PANEL  
(18") 側板

**H.C.B-E2060** ..... P144  
14 DRAWER ROLLER TOOL CABINETS  
14抽滾輪工具櫃

 **H.C.B-F2060** ..... P144  
3 DRAWER DOUBLE SIDED TROLLEY  
3抽雙開工具車

**H.C.B-A1051-1** ..... P145  
PUNCHED BOARD (885 mm x 870 mm)  
洞洞板(3尺 X 3尺)

**H.C.B-A1051-2** ..... P145  
PUNCHED BOARD  
(L: 1800 mm x W: 865 mm x H: 20 mm)  
洞洞板(長: 1800 mm x 寬: 865 mm x 高: 20 mm)

**H.C.B-A1051-3** ..... P145  
3" FIXED HOOK  
3"洞洞勾

**H.C.B-A1051-4** ..... P146  
PUNCHED BOARD (561 mm x 866 mm x 20 mm)  
洞洞板(561 mm x 866 mm x 20 mm)

**H.C.B-C1051** ..... P147  
TOOL CABINET  
壁櫃

**H.C.B-A2230** ..... P148  
Dr. 3/4" TX-STAR & SPLINE IMPACT BIT SOCKET  
KIT (6 PCS)  
Dr. 3/4" 氣動星形 12角凸型套筒組 (6PCS)

**H.C.B-B2230** ..... P148  
3/4" SQ. DRIVE HEXAGON & SPLINE IMPACT BIT  
SOCKET KIT (9PCS) (61 mm)  
(14/17/19/21/22/23/24 mm/M16/M18)  
Dr. 3/4" 氣動六角&12角套筒組  
(9 PCS)(61 mm) (14/17/19/21/22/23/24 mm/M16/M18)

**H.C.B-C2230** ..... P148  
3/4" SQ. DRIVE HEXAGON & TX-STAR IMPACT BIT  
SOCKET KIT (9PCS) (61 mm)  
(19/21/22/23/24 mm/T70/80/90/100)  
Dr. 3/4" 氣動星形12角凸型套筒組  
(9 PCS) (61 mm) (19/21/22/23/24 mm/T70/80/90/100)

**H.C.B-A2283** ..... P148  
Dr.1/2" DEEP IMPACT SOCKET KIT(13 PCS)  
(10/11/12/13/14/16/17/19/21/22/24/27/30 mm)  
Dr.1/2" 長型氣動套筒組(13 PCS)  
(10/11/12/13/14/16/17/19/21/22/24/27/30 mm)

**H.C.B-B2138** ..... P149  
WORKING TABLE (CABINET)  
美式工作桌(加壁櫃)

**H.C.B-B2138-1** ..... P149  
FIXED HOOK  
壁櫃掛勾

 **H.C.B-A2316** ..... P149  
MECHANICS CREEPER  
臥板

**H.C.B-A6005-5** ..... P150  
TOOL HOLDER(5 SLICES)  
工具櫃(五片)

# Index



**HWANG CHERNG BIN**  
Specialty Tools Inc.



H.C.B-A1009 ----- P80	H.C.B-A1066-2 ----- P16	H.C.B-A1120-309 ---P81
H.C.B-A1015 ----- P92	H.C.B-A1066-3-1--- P16	H.C.B-A1120-310 ---P81
H.C.B-B1050-1 ----- P1	H.C.B-A1066-3-2--- P16	H.C.B-B1120 -----P82
H.C.B-A1050-2 ----- P13	H.C.B-A1066-5 ----- P61	H.C.B-B1120-A----- P82
H.C.B-B1050-2 ----- P13	H.C.B-A1071 -----P18	H.C.B-B1120-B----- P82
H.C.B-A1050-3 ----- P14	H.C.B-A1073 -----P140	H.C.B-B1120-C----- P82
H.C.B-B1050-3 ----- P14	H.C.B-A1075 -----P18	H.C.B-A1122 -----P60
H.C.B-A1050-4 ----- P14	H.C.B-B1075 -----P18	H.C.B-A1125 -----P4
H.C.B-B1050-5 ----- P1	H.C.B-C1076 -----P140	H.C.B-B1125 -----P4
H.C.B-A1050-6 ----- P14	H.C.B-A1082-1 ----- P79	H.C.B-C1125 -----P4
H.C.B-B1050-6 ----- P15	H.C.B-A1090 -----P1	H.C.B-A1126 -----P4
H.C.B-C1050-6 ----- P15	H.C.B-B1090 -----P2	H.C.B-B1126 -----P5
H.C.B-D1050-6 ----- P15	H.C.B-C1090 -----P2	H.C.B-C1126 -----P5
H.C.B-B1050-7 ----- P1	H.C.B-D1090 -----P2	H.C.B-A1127 -----P56
H.C.B-A1050-8 ----- P1	H.C.B-E1090 -----P2	H.C.B-A1135-R -----P141
H.C.B-A1051-1 ----- P145	H.C.B-F1090 -----P3	H.C.B-A1165 -----P77
H.C.B-A1051-2 ----- P145	H.C.B-G1090 -----P3	H.C.B-A1167 -----P5
H.C.B-A1051-3 ----- P145	H.C.B-B1091 -----P3	H.C.B-F1168 -----P90
H.C.B-A1051-4 ----- P146	H.C.B-C1091 -----P3	H.C.B-A1169 -----P23
H.C.B-C1051 -----P147	H.C.B-A1102 -----P76	H.C.B-A1170 -----P64
H.C.B-A1054-2 ----- P88	H.C.B-B1102 -----P23	H.C.B-A1171----- P16
H.C.B-A1054-4 ----- P88	H.C.B-C1102 -----P62	H.C.B-B1171 -----P17
H.C.B-B1056 -----P59	H.C.B-A1112 -----P76	H.C.B-C1171 -----P17
H.C.B-A1065 -----P99	H.C.B-A1120 -----P80	H.C.B-A1172 -----P18
H.C.B-A1066-1 ----- P15	H.C.B-A1120-308---P81	H.C.B-B1172 -----P19





**HWANG CHERNG BIN**  
Specialty Tools Inc.







H.C.B-A1175----- P23	H.C.B-A1203 ----- P19	H.C.B-A1270----- P58
H.C.B-B1175----- P24	H.C.B-A1210----- P58	H.C.B-A1271----- P36
H.C.B-A1176----- P24	H.C.B-A1222----- P86	H.C.B-A1271-A----- P36
H.C.B-A1177----- P54	H.C.B-A1225----- P79	H.C.B-A1271-B----- P36
H.C.B-A1178----- P57	H.C.B-A1226----- P79	H.C.B-A1271-C----- P36
H.C.B-B1178----- P57	H.C.B-A1227----- P5	H.C.B-A1271-D----- P36
 H.C.B-C1178----- P58	H.C.B-A1228----- P19	H.C.B-A1271-E----- P36
H.C.B-A1179----- P63	H.C.B-A1229----- P25	H.C.B-A1271-F----- P36
H.C.B-A1180----- P63	H.C.B-A1236----- P6	H.C.B-A1271-G----- P36
H.C.B-A1181----- P8	H.C.B-A1238----- P25	H.C.B-A1271-H----- P36
H.C.B-B1181----- P63	H.C.B-B1238----- P25	H.C.B-B1271----- P37
H.C.B-C1181----- P84	H.C.B-A1239----- P20	 H.C.B-C1271----- P37
H.C.B-D1181----- P84	H.C.B-A1242----- P40	H.C.B-A1273----- P19
H.C.B-E1181----- P84	H.C.B-A1244----- P35	H.C.B-A1274----- P20
 H.C.B-F1181----- P85	H.C.B-A1246----- P25	H.C.B-A1275----- P59
H.C.B-B1182----- P79	H.C.B-A1247----- P25	H.C.B-B1277----- P7
H.C.B-A1183----- P83	H.C.B-A1248----- P58	H.C.B-A1278----- P6
H.C.B-A1184----- P56	H.C.B-A1256----- P88	H.C.B-A1279----- P86
H.C.B-B1184----- P56	H.C.B-A1257----- P6	H.C.B-A1280----- P45
H.C.B-C1184----- P57	H.C.B-A1261----- P60	H.C.B-A1281----- P17
H.C.B-A1186----- P24	H.C.B-B1261----- P60	H.C.B-A1282----- P45
H.C.B-B1186----- P24	H.C.B-A1263----- P40	H.C.B-A1283----- P45
H.C.B-A1187----- P83	H.C.B-A1265----- P6	H.C.B-A1284----- P7
H.C.B-A1190----- P35	H.C.B-B1265----- P7	H.C.B-A1286----- P59
H.C.B-A1191----- P85	H.C.B-A1269----- P26	H.C.B-A1287----- P89

# Index



**HWANG CHERNG BIN**  
Specialty Tools Inc.





































H.C.B-A1314----- P40	H.C.B-A1353----- P10	H.C.B-C1410----- P78
H.C.B-B1314----- P40	H.C.B-B1353----- P10	H.C.B-A1411-95----P43
H.C.B-A1319----- P8	H.C.B-A1363----- P27	H.C.B-A1411-98----P43
H.C.B-A1320----- P108	H.C.B-A1380----- P27	H.C.B-A1412----- P120
H.C.B-B1320----- P108	H.C.B-A1383----- P88	H.C.B-A1415----- P65
H.C.B-B1320-7090-P109	H.C.B-A1384----- P42	 H.C.B-B1415----- P65
H.C.B-A1328----- P20	H.C.B-A1387----- P42	H.C.B-A1422----- P45
H.C.B-A1329----- P20	H.C.B-B1387----- P42	H.C.B-A1423----- P29
H.C.B-A1335----- P26	H.C.B-C1387----- P42	H.C.B-A1432----- P35
H.C.B-A1336----- P110	H.C.B-A1390----- P47	H.C.B-A1434----- P48
H.C.B-A1337----- P111	H.C.B-B1391----- P87	H.C.B-A1435----- P113
H.C.B-B1337----- P111	H.C.B-C1391----- P87	H.C.B-A1439----- P65
H.C.B-C1337----- P112	H.C.B-D1391----- P13	H.C.B-A1441----- P41
H.C.B-D1337----- P112	H.C.B-E1391----- P13	H.C.B-A1442----- P41
 H.C.B-E1337----- P112	H.C.B-A1393----- P27	H.C.B-A1443----- P41
H.C.B-A1338----- P65	H.C.B-B1393----- P28	H.C.B-A1444----- P11
H.C.B-A1339----- P112	H.C.B-A1397----- P62	 H.C.B-A1448----- P50
H.C.B-B1339----- P113	H.C.B-A1398----- P35	H.C.B-A1454----- P34
H.C.B-C1339----- P114	H.C.B-A1402----- P28	H.C.B-A1462----- P29
H.C.B-A1344----- P21	 H.C.B-B1402----- P9	H.C.B-A1465----- P34
H.C.B-A1345----- P21	H.C.B-A1403----- P48	H.C.B-A1466----- P50
H.C.B-A1350----- P8	H.C.B-A1404----- P48	H.C.B-A1472----- P66
H.C.B-B1350----- P26	H.C.B-A1407----- P76	H.C.B-A1478----- P11
H.C.B-A1351----- P61	H.C.B-A1409----- P38	H.C.B-A1481----- P122
 H.C.B-B1351----- P61	H.C.B-A1410----- P77	H.C.B-B1481----- P122





**HWANG CHERNG BIN**  
Specialty Tools Inc.



H.C.B-C1481----- P122	H.C.B-A1521----- P34	 H.C.B-A1603----- P44
H.C.B-D1481----- P122	H.C.B-A1538----- P125	 H.C.B-A1606----- P9
H.C.B-E1481----- P122	H.C.B-A1541----- P141	 H.C.B-B1606----- P9
H.C.B-F1481----- P122	H.C.B-A1557-50 --- P52	 H.C.B-A1608----- P30
H.C.B-A1482----- P50	H.C.B-A1557-90 --- P52	 H.C.B-A1609----- P30
H.C.B-A1483----- P50	H.C.B-A1560----- P125	 H.C.B-A1610----- P54
H.C.B-A1488----- P109	H.C.B-B1560----- P125	 H.C.B-A1614----- P31
H.C.B-B1488----- P109	H.C.B-C1560----- P126	 H.C.B-A1615----- P31
 H.C.B-B1488-120---P49	H.C.B-D1560----- P126	 H.C.B-A1616----- P31
H.C.B-A1490----- P12	 H.C.B-E1560----- P127	 H.C.B-A1617----- P32
 H.C.B-B1490----- P12	 H.C.B-F1560----- P30	 H.C.B-A1618----- P44
 H.C.B-C1490----- P12	H.C.B-A1561----- P43	 H.C.B-A1625----- P70
H.C.B-A1491----- P67	H.C.B-A1562----- P53	 H.C.B-A1626----- P32
 H.C.B-B1491----- P67	H.C.B-A1569----- P55	 H.C.B-A1627----- P32
 H.C.B-C1491----- P67	H.C.B-A1572----- P53	 H.C.B-B1627----- P32
H.C.B-A1492----- P51	H.C.B-A1579----- P69	 H.C.B-C1627----- P33
H.C.B-A1493----- P51	H.C.B-B1579----- P69	 H.C.B-A1628----- P68
H.C.B-A1494----- P51	 H.C.B-C1579----- P70	 H.C.B-A1630----- P10
H.C.B-A1495-1----- P66	H.C.B-A1581----- P53	 H.C.B-A1634----- P44
H.C.B-A1495-2----- P66	H.C.B-A1582----- P53	 H.C.B-A1635----- P71
H.C.B-A1497----- P121	H.C.B-A1586----- P70	 H.C.B-A1636----- P39
H.C.B-A1502----- P123	H.C.B-A1592----- P110	 H.C.B-A1641----- P106
H.C.B-B1502----- P124	 H.C.B-A1601----- P44	 H.C.B-A1646----- P33
H.C.B-C1502----- P124	 H.C.B-A1602----- P38	 H.C.B-A1654----- P33
H.C.B-A1520----- P68	 H.C.B-B1602----- P39	 H.C.B-A1655----- P93

# Index



HWANG CHERNG BIN  
Specialty Tools Inc.



H.C.B-A1661----- P54



H.C.B-A1663----- P33



H.C.B-A1665----- P85

## H.C.B-A2~

H.C.B-A2001----- P141

H.C.B-A2005----- P133

H.C.B-A2005-1----- P133

H.C.B-A2009 ----- P102

H.C.B-A2010----- P142

H.C.B-A2011----- P142

H.C.B-A2013----- P89

H.C.B-A2018 -----P71

H.C.B-A2018-1-----P71

H.C.B-A2018-2-----P72

H.C.B-A2018-3----- P29

H.C.B-A2018-5-----P72

H.C.B-A2018-11---- P72

H.C.B-A2018-12---- P72

H.C.B-A2018-13---- P73

H.C.B-A2018-14---- P73

H.C.B-A2018-17---- P73

H.C.B-A2018-18---- P73

H.C.B-A2018-19---- P21

H.C.B-A2018-20---- P74

H.C.B-A2018-21---- P74

H.C.B-A2018-22---- P74

H.C.B-A2018-23---- P74

H.C.B-A2018-24---- P75

H.C.B-A2018-25---- P75

H.C.B-A2018-26---- P52

H.C.B-A2018-27---- P89

H.C.B-A2019----- P90

H.C.B-A2021----- P102

H.C.B-A2022----- P102

H.C.B-B2025----- P133

H.C.B-A2034----- P134

H.C.B-A2045----- P93

H.C.B-A2046----- P134

H.C.B-A2047----- P134

H.C.B-A2048----- P134

H.C.B-A2050----- P114

H.C.B-A2050-1-----P114

H.C.B-A2050-2-----P114

H.C.B-B2050----- P114

H.C.B-A2060----- P143

H.C.B-B2060----- P143

H.C.B-C2060----- P143

H.C.B-D2060----- P143

H.C.B-E2060----- P144



H.C.B-F2060----- P144

H.C.B-A2061----- P118

H.C.B-A2086----- P103

H.C.B-A2094----- P114

H.C.B-B2094----- P115

H.C.B-D2094----- P115

H.C.B-A2101----- P91

H.C.B-A2102----- P91



H.C.B-B2102----- P91

H.C.B-A2107----- P105



H.C.B-B2107----- P105

H.C.B-B2115----- P92

H.C.B-A2121----- P115

H.C.B-B2121----- P115

H.C.B-C2121----- P116

H.C.B-D2121----- P116

H.C.B-B2126----- P95

H.C.B-B2127----- P95

H.C.B-A2128----- P119

H.C.B-B2128----- P119

H.C.B-C2128----- P119

H.C.B-D2128----- P120

H.C.B-A2130----- P75



















H.C.B-A2132----- P22

H.C.B-B2132----- P22

H.C.B-C2132----- P22

H.C.B-B2138----- P149



H.C.B-B2138-1----- P149	H.C.B-B2197----- P118	H.C.B-A2286----- P136
H.C.B-A2139----- P135	H.C.B-A2200----- P135	H.C.B-B2286----- P136
H.C.B-A2145----- P103	 H.C.B-B2200----- P135	H.C.B-A2287----- P136
H.C.B-A2146----- P95	H.C.B-A2203----- P97	 H.C.B-B2294----- P116
H.C.B-A2147----- P99	H.C.B-A2204----- P97	 H.C.B-C2294----- P117
H.C.B-A2148----- P99	H.C.B-A2205----- P98	 H.C.B-C2297----- P129
H.C.B-A2157----- P100	H.C.B-A2206----- P98	 H.C.B-A2299----- P129
H.C.B-A2158----- P100	H.C.B-A2209----- P104	 H.C.B-A2300----- P130
H.C.B-B2158----- P101	H.C.B-A2212----- P46	 H.C.B-A2301----- P130
H.C.B-A2160----- P96	H.C.B-A2222----- P47	 H.C.B-A2302----- P131
 H.C.B-B2160----- P96	H.C.B-A2226----- P101	 H.C.B-A2306----- P131
H.C.B-A2165----- P94	H.C.B-B2226----- P101	 H.C.B-A2307----- P132
H.C.B-B2165----- P94	H.C.B-C2226----- P101	 H.C.B-A2309----- P132
H.C.B-C2165----- P94	H.C.B-A2228----- P10	 H.C.B-A2310----- P132
H.C.B-D2165----- P94	H.C.B-A2230----- P148	 H.C.B-A2313----- P68
H.C.B-A2166----- P104	H.C.B-B2230----- P148	 H.C.B-B2313----- P69
H.C.B-A2168----- P104	H.C.B-C2230----- P148	 H.C.B-A2316----- P149
H.C.B-A2170----- P107	H.C.B-A2258----- P127	H.C.B-A3005----- P121
H.C.B-A2173----- P135	H.C.B-A2269----- P139	H.C.B-A3036----- P137
H.C.B-A2177----- P105	H.C.B-A2270----- P139	H.C.B-B3036----- P137
H.C.B-A2178----- P46	H.C.B-A2273----- P128	H.C.B-C3036----- P137
H.C.B-B2192----- P106	H.C.B-A2280----- P128	H.C.B-D3036----- P137
H.C.B-A2193----- P11	H.C.B-A2281----- P128	H.C.B-E3036----- P138
 H.C.B-C2195----- P117	H.C.B-A2282----- P129	 H.C.B-F3036----- P138
H.C.B-A2197----- P118	H.C.B-A2283----- P148	H.C.B-A6001----- P121
	H.C.B-A2285----- P136	H.C.B-A6005-5----- P150



SINCE 1990

HWANG CHERNG BIN  
Specialty Tools Inc.

# 歐系卡車修護工具

EUROPEAN TRUCK REPAIR TOOL







歐系卡車修護工具

European Truck Repair Tool



011

HWANG CHERNG BIN  
Specialty Tools Inc.



### H.C.B-B1050-1 SCANIA FRONT WHEEL SHOCK ABSORBER SPRING WASHER SOCKET (Dr. 3/4")

SCANIA 前輪避震器彈簧墊片拆裝套筒 (Dr. 3/4")  
30 / 13.8 / 14.8 / 0.9'

ON TRUCK

### H.C.B-B1050-5 SCANIA REAR AXLES DAMPER ROD SOCKET (Dr. 3/4")

SCANIA 後輪避震器彈簧墊片拆裝套筒 (Dr. 3/4")  
30 / 20 / 21 / 1'

### H.C.B-B1050-7 SCANIA REAR WHEEL SHOCK ABSORBER SPRING WASHER SOCKET (Dr.3/4")

SCANIA 後輪避震器彈簧墊片拆裝套筒 (Dr. 3/4")  
30 / 23.2 / 24.2 / 1'



PART SIZE

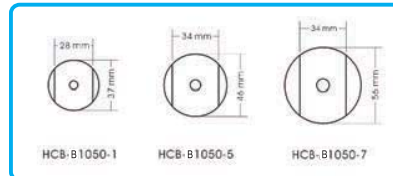

可在車上拆裝SCANIA卡車避震器彈簧墊片

### H.C.B-A1050-8 SCANIA 10 WHEELS CAB THIRD AXLE NUT SOCKET (Dr. 3/4", 8 POINTS, 95 mm)

SCANIA 10輪拖車頭第三軸螺帽套筒  
(Dr. 3/4", 8角, 95 mm)  
10 / 25.5 / 26.5 / 0.72'

- Application: SCANIA trailer, YORK haulage, FUSO 10.5 tons truck
- 適用車種：SCANIA拖車, YORK板車, FUSO 10.5噸卡車



FUSO ORIGINAL PARTS  
NO. : MC870996  
FUSO零件編號：MC870996

YORK



### H.C.B-A1090 SCANIA TRUCK (310 / 320 / 340) TRANSMISSION SOCKET (Dr. 3/4")

SCANIA 卡車 (310/320/340) 變速箱專用套筒 (Dr. 3/4")  
12 / 14.7 / 15.7 / 1.53'

- Use for Scania transmission flange shaft on transmission and rear axle
- Application: SCANIA 310(112)/320(113) /340(114) Rear spindle(8/10 speed)
- 適用車種：SCANIA 310(112) /320(113) /340(114) 後主軸 (8/10速)
- 原廠編號：98285

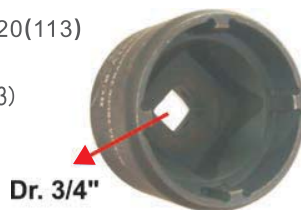

NUT SIZE

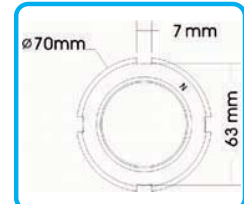

NUT SIZE

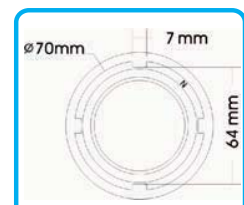



011

HWANG CHERNG BIN  
Specialty Tools Inc.

歐系卡車修護工具

European Truck Repair Tool



European Truck  
Repair Tool(SCANIA)

### H.C.B-B1090 SCANIA TRANSMISSION CLUTCH FRONT MAIN SHAFT SOCKET (Dr. 3/4")

SCANIA 變速箱離合器前主軸螺帽套筒 (Dr. 3/4")

12 / 17.5 / 18.5 / 1.53'

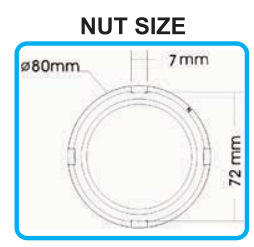
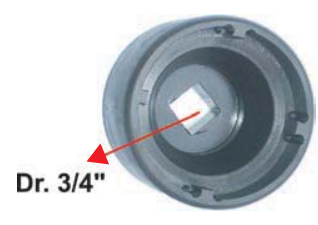

### H.C.B-C1090 SCANIA 8-SPEED BUS TRANSMISSION NUT SOCKET (Dr. 3/4")

SCANIA 變速箱螺帽拆裝套筒 (遊覽車8速) (Dr. 3/4")

12 / 22.5 / 23.5 / 1.53'



### H.C.B-D1090 SCANIA TRANSMISSION CLUTCH FRONT MAIN AXLE NUT SOCKET (Dr. 3/4")

SCANIA 變速箱離合器前主軸螺帽套筒 (Dr. 3/4")

12 / 13.3 / 14.3 / 1.53'

- For extracting / installing the front main axle of transmission clutch nut on SCANIA truck with ten speeds automatic transmission.
- 可拆裝SCANIA 10速自動變速箱前主軸離合器的螺帽。

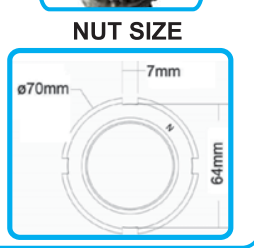

### H.C.B-E1090 SCANIA PTO NUT SOCKET (Dr. 1/2")

SCANIA 卡車PTO螺帽拆裝套筒 (Dr. 1/2")

20 / 18 / 19 / 0.5'

- For removing / replacing the SCANIA hauler tractor truck PTO nut, also for third axle hanger nut on the trailer.
- 可移除、更換SCANIA拖車頭的PTO螺帽及拖車第三軸的懸掛螺帽。

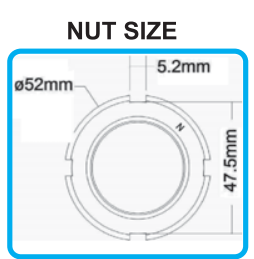



### H.C.B-F1090

### SCANIA (340) TRANSMISSION CLUTCH FRONT MAIN SHAFT SOCKET (Dr. 3/4")

SCANIA (340) 變速箱離合器前主軸螺帽套筒 (Dr. 3/4")

- For extracting/ installing the front main shaft of transmission clutch nut on SCANIA (340) truck
- Application : SCANIA (340) Truck.
- 可拆裝SCANIA 340自動變速箱前主軸離合器的螺帽
- 適用車種 : SCANIA (340)卡車

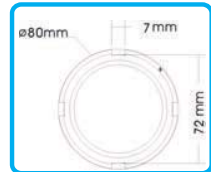

### H.C.B-G1090

### SCANIA DIFFERENTIAL REAR AXLE NUT SOCKET (Dr. 3/4")

SCANIA 差速器後輪軸螺母套筒 (Dr. 3/4")

- For removing/installing differential rear pinion nut.
- Genuine stock : 1338267
- Application: SCANIA (3- series) differential gear rear nut. EX :RB660,RB662,RBP735/835...
- 拆除/安裝差速器後輪軸螺母.
- 螺母原廠料號 : 1338267
- 適用車種: SCANIA (3系列) 差速器後輪軸螺母, EX :RB660,RB662,RBP735/835...

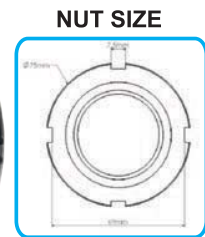

### H.C.B-B1091

### SCANIA TRUCK FRONT WHEEL AXLES HUB EXTRACTOR

SCANIA 卡車前輪仰角HUB拆卸器

- When SCANIA axle bearing is stuck due to it's overheating, use H.C.B-B1091 with air wrench for labor saver and easier removal.
- 當SCANIA卡車輪軸軸承過熱咬死, 使用此工具搭配氣動扳手拆卸, 變得更輕鬆、容易。



### H.C.B-C1091

### SCANIA TRUCK FRONT WHEEL AXLES HUB EXTRACTOR (W/HYDRAULIC CYLINDER)

SCANIA卡車前輪仰角HUB拆卸器 (油壓式)

- The tool can be easily operated if combine with H.C.B-B1129 which can save time and increase working efficiency (Hydraulic Hand Pump) while SCANIA axle bearing gets stuck due to overheating.
- SCANIA卡車輪軸軸承過熱咬死, 使用此工具並搭配H.C.B-B1129 (油壓幫浦)使用, 既省力又方便有效率, 是您賺錢的最佳利器。





011

HWANG CHERNG BIN  
Specialty Tools Inc.

歐系卡車修護工具

European Truck Repair Tool



European Truck  
Repair Tool(SCANIA)

### H.C.B-A1125

### SCANIA FRONT WHEEL NUT SOCKET (H41, 8 POINTS, 80 mm)

SCANIA 前輪螺帽拆裝套筒 (H41, 8角, 80 mm)

12 / 21.2 / 23.3 / 0.84'

Size: 8 points, 80 mm  
Application: SCANIA  
適用車種: SCANIA



Step 1: Extract the front axle plastic cover by H.C.B-A1167 socket. (6 points, 27 mm) (Only for SCANIA 340)

步驟1: 先用H.C.B-A1167 (6角, 27 mm套筒) 移除前輪軸上的塑膠蓋。(本步驟只用於SCANIA 340)

### H.C.B-B1125

### SCANIA FRONT WHEEL NUT SOCKET (Dr. 3/4", 8 POINTS, 80 mm)

SCANIA 前輪螺帽拆裝套筒 (Dr. 3/4", 8角, 80 mm)

12 / 21 / 22 / 0.74'



Step 2: Remove the front wheel nut with this tool.

步驟2: 用本工具轉開前輪螺帽。

### H.C.B-C1125

### SCANIA FRONT WHEEL NUT SOCKET (Dr. 1", 8 POINTS, 80 mm)

SCANIA 前輪螺帽拆裝套筒 (Dr. 1", 8角, 80 mm)

12 / 21.5 / 22 / 0.93'



### H.C.B-A1126

### SCANIA REAR WHEEL NUT SOCKET (8 POINTS, 100 mm)

SCANIA 後輪螺帽拆裝套筒 (8角, 100 mm)

4 / 24 / 26 / 2.45'

- Fix bearing while removing or installing the truck nut.
- Control the nut with slide rod to adjust bearing.
- 拆卸、安裝卡車螺帽時，用來固定培林
- 配合扳手使用，來進行拆裝

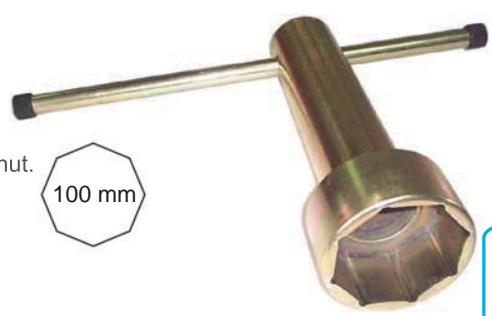



**H.C.B-B1126**

**SCANIA REAR WHEEL NUT SOCKET (Dr. 3/4", 8 POINTS, 100 mm)**

SCANIA 後輪螺帽拆裝套筒 (Dr. 3/4", 8角, 100 mm)

8 / 20.9 / 22 / 0.88'

- Control the nut with slide rod to adjust bearing.
- 配合扳手使用，來進行拆裝

VIDEO



**H.C.B-C1126**

**SCANIA REAR WHEEL SOCKET (Dr. 1", 8 POINTS, 100 mm)**

SCANIA 後輪螺帽拆裝套筒 (Dr. 1", 8角, 100 mm)

8 / 22 / 22.5 / 0.74'



**H.C.B-A1167**

**SCANIA, BENZ (W203 / W209) WRENCH SOCKET (FLUID RESERVOIR ON CONDENSER) (Dr. 1/2", 27 mm)**

SCANIA, BENZ (W203 / W209)  
冷凝器貯油槽套筒扳手 (Dr. 1/2", 27mm)

- For screw plug removal and installation on fluid reservoir on condenser
- Also used for SCANIA front wheel plastic cover.
- Application: BENZ (W203/W209) & SCANIA truck
- Genuine Stock No.: 203 589 00 10 00

- 用來拆裝冷凝器貯油槽的套筒
- 也可用在SCANIA前輪塑膠蓋
- 適用車種: BENZ (W203/W209) · SCANIA
- 原廠料號: 203 589 00 10 00



SCANIA(P340)



BENZ(W203)

**H.C.B-A1227**

**SCANIA TRUCK FLYWHEEL ROTATOR (Dr. 1/2")**

SCANIA 卡車曲軸飛輪轉動器 (Dr. 1/2")

- The tool is designed to rotate the crankshaft for engine timing
- Application: SCANIA Truck
- 使用1/2" 扳桿轉動齒輪，以供正時使用
- 適用車種：SCANIA卡車





011

HWANG CHERNG BIN  
Specialty Tools Inc.

歐系卡車修護工具

European Truck Repair Tool



European Truck  
Repair Tool(SCANIA)

### H.C.B-A1236

### SCANIA (320/340/360) KING PIN EXTRACTOR (10 WHEELS)

SCANIA (320/340/360) 大王銷拆卸器 (10輪)

- For removing the SCANIA (320/340/360) king pin.
- 可用來拆卸SCANIA (320/340/360) 的大王銷，請配合氣動扳手使用。



### H.C.B-A1257

### SCANIA (340) ELECTROMAGNETIC INJECTION VALVE CAP SOCKET (Dr. 1/2", 8 POINTS, 38 mm)

SCANIA (340) 電磁閥噴油嘴蓋套筒 (Dr. 1/2", 8角, 38mm)

- For tightening & loosening the electromagnetic injection valve cap.
- Application: SCANIA(340)trailer
- 可用來旋緊和鬆開電磁閥的噴油嘴蓋。
- 適用車種：SCANIA 340拖車

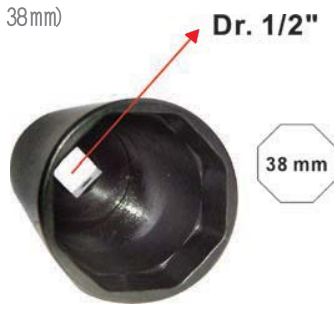

Scania Genuine Stock No.:

1529752 8075

119966 0332 5

016 868

USA

### H.C.B-A1278

### SCANIA (420) AXLE HUB NUT SOCKET (Dr. 3/4", 8 TEETH)

SCANIA (420) 輪軸螺帽套筒 (Dr. 3/4", 8齒)

8 / 22.5 / 23 / 0.69"

- Fix bearing while removing or installing the truck nut.
- Application: SCANIA 420
- 拆卸安裝卡車螺帽時，用來固定培林
- 適用車種：SCANIA 420



### H.C.B-A1265

### SCANIA (320/340) / VOLVO (FM12) PITMAN ARM PULLER (Dr. 3/4", 58 mm)

SCANIA (320/340) / VOLVO (FM12) 方向機搖臂拆卸器 (Dr. 3/4", 58 mm)

4 / 24.5 / 25 / 1.64"

- Used on the pitman arm of European trucks. No need to destroy the pitman arm.
- Application: European truck. Such as SCANIA, VOLVO(FM12).
- Loosen the fixed nut on the arm before using H.C.B-A1265.
- 用於歐系卡車的方向機搖臂上，不需要破壞方向機搖臂。
- 適用車種：歐系卡車。如：SCANIA . VOLVO FM12。
- 使用H.C.B-A1265之前，要先鬆開方向機搖臂的上固定螺帽。



Bolt Size: TM42 x P3.0







### H.C.B-B1265

### SCANIA (320/340)/VOLVO (FM12) PITMAN ARM PULLER (58 mm) (W/HYDRAULIC CYLINDER)

SCANIA (320/340) / VOLVO (FM12) 方向機搖臂拆卸器 (58 mm) (油壓式)

- Used on the pitman arm of European trucks. No need to destroy the pitman arm.
- Designed to combine with hydraulic pump.
- Application: European truck. Such as SCANIA, VOLVO (FM12).
- Loosen the fixed nut on the arm before using H.C.B-B1265.
- Thread-outside dimension of cylinder : Ø50 x 16UNF
- 用於歐系卡車的方向機搖臂上，不需要破壞方向機搖臂。
- 可搭配油壓幫浦使用。(H.C.B-B1129) 省力好用
- 適用車種：歐系卡車。如：SCANIA, VOLVO FM12。
- 使用H.C.B-B1265之前，要先鬆開方向機搖臂的上固定螺帽。
- 油壓缸外牙尺寸：φ50 x 16UNF



European Truck Repair Tool(SCANIA)

### H.C.B-B1277

### SCANIA (320/340) / VOLVO (FM12) / MAN (FE414) STEERING MECHANISM BEARING PULLER

SCANIA (320/340) / VOLVO (FM12) / MAN (FE414) 方向機培林拔卸組

- Designed to remove the bearing of steering mechanism and replace oil seal.
- Application: SCANIA 320 (113)/340 (114), MAN (FE414) (Genuine no. of bearing 10-8325) VOLVO (FM12)
- 依照SCANIA車種挑選適合配件，拆下培林以方便更換油封。
- 適用車種：SCANIA 320(113)/340(114)，MAN (FE414) (培林料號：10-8325) VOLVO (FM12)



SCANIA 320 Bearing



### H.C.B-A1284

### SCANIA TRANSMISSION REAR OIL SEAL INSTALLER

SCANIA 變速箱後油封安裝器

- The seals are on the shaft that control the direction. They are different from the ones on gear box and axle gear.
- Strictly prohibited to drive the seal and thrust piece back by hammer or drill.
- Genuine stick of oil seal: 1 502 384, 1 502 385
- 油封位於旋轉方向的軸上，和位於齒輪箱及齒輪軸上的不同。
- 嚴禁使用榔頭把油封推到定點。
- 油封料號：1 502 384, 1 502 385

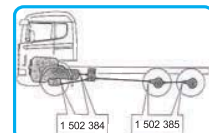

Press seal onto thrust piece by H.C.B-A1284. Then press thrust piece and seal onto shaft. 用H.C.B-A1284將油封壓回推動件中，再將推動件和油封壓回軸中。





011

HWANG CHERNG BIN  
Specialty Tools Inc.

歐系卡車修護工具

European Truck Repair Tool



European Truck  
Repair Tool(SCANIA)

### H.C.B-A1181

### SCANIA & VOLVO SPRING PIN METAL BUSH REMOVAL /INSTALLATION TOOL KIT (W/ HYDRAULIC CYLINDER)

SCANIA & VOLVO卡車彈簧銷拆裝工具組(油壓式)

1 / 11.5 / 12 / 0.86'

- Parts no. 4,5,6 and 7 are changeable to fit most kinds of SCANIA & VOLVO trucks.
- Allow easier replacement of spring pin .Save money and labor.
- Optional: H.C.B-B1129 HYDRAULIC HAND PUMP
- Application: The length of brass bush under 120 mm
- 第4、5、6、7號的零件可替換。請挑選適合的尺寸，以用於SCANIA 和VOLVO卡車。
- 可輕鬆地更換彈簧銷，省錢又省力。
- 選購配備：H.C.B-B1129手搖幫浦
- 適用範圍：長度在120 mm以下的黃銅套。

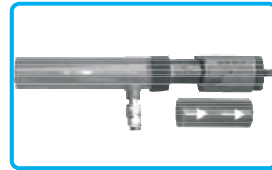

BRASS BUSH  
APPLICATION:  
SCANIA & VOLVO TRUCK



### H.C.B-A1319

### SCANIA (310/320) CRANKSHAFT REAR OIL SEAL INSTALLER

SCANIA (310/320)曲軸後油封安裝器

- Put new oil seal onto crankshaft. (Fig. 1)
- Put H.C.B-A1319 above the oil seal and hit it to force oil seal install to the right place. (Fig. 2)
- Application : SCANIA 310(112)/ 320(113)
- Oil seal no. 0366303-R
- 放置新油封到曲軸上。(Fig. 1)
- 把H.C.B-A1319放到油封上，藉由槌打工具有將油封安裝到正確的位置。(Fig. 2)
- 適用車種：SCANIA 310(112)/320(113)
- 油封料號：0366303-R



Oil Seal No.  
0366303-R

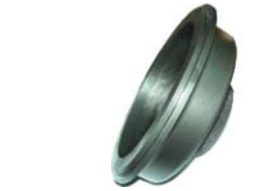

### H.C.B-A1350

### SCANIA RADIATOR ADAPTOR

SCANIA 水箱快速接頭

- Female adaptor for radiator when draining or refilling radiator liquid.
- Application: SCANIA 340/360 truck and bus.
- 用於排出或灌注水箱水的快速接頭。
- 適用車種：SCANIA 340/360卡車和巴士

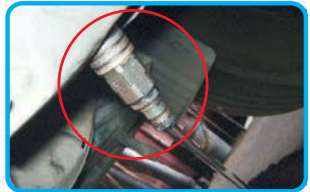

VIDEO





歐系卡車修護工具

European Truck Repair Tool



011

HWANG CHERNG BIN  
Specialty Tools Inc.



## H.C.B-A1606

**NEW**

### SCANIA 340/380 (EURO 4) CRANKSHAFT FRONT/REAR OIL SEAL INSTALLER(PR SERIES)

SCANIA 340/380(4期環保車) 曲軸前後油封安裝工具組(PR系列)

- Description: When installing the oil seal, you won't damage the oil seal. With this tool kit will make repair more convenient and easier.
- Application: SCANIA 340/380 (PR Series)
- Oil seal genuine no.: 143 31 83

- 使用說明: 此工具在安裝油封的過程中, 不會損壞到油封, 並且更快速、簡便。
- 適用車種: SCANIA 340/380 (PR系列)
- 油封料號: 143 31 83



Screw the nut until finish installing.



Finish installing.

## H.C.B-B1606

**NEW**

### SCANIA (114) 340/360/380 CRANKSHAFT FRONT OIL SEAL INSTALLER

SCANIA(114) 340/360/380曲軸前油封安裝工具

- This tool is designed to install crankshaft front oil seal. It can install the oil seal without damage the oil seal and related parts.
- Oil seal OEM no: 1392708
- Application: SCANIA (114) 340/360/380 truck.
- 此工具為安裝曲軸前油封。在安裝油封過程快速、準確, 不會損壞到油封及零件。
- 油封料號: 1392708
- 適用車種: SCANIA(114) 340/360/380卡車

VIDEO



1392708



## H.C.B-B1402

**NEW**

### SCANIA (340/360/380) VALVE SPRING COMPRESSOR TOOL KIT

SCANIA (340/360/380) 汽門彈簧壓縮工具組

- Feature: It won't need to remove the cylinder when you replace oil seal. It will save you 7~8 hours when you work.
- Application: SCANIA (340/360/380) TRUCK
- The size for the screw: M10 x P1.5, L: 25 mm
- 說明:此工具讓你在更換油封時, 免拆卸氣缸蓋, 可節省7~8小時的時間, 並能輕鬆移除及安裝 SCANIA (340/360/380)汽門彈簧油封。
- 適用車種: SCANIA (340/360/380)卡車
- 螺絲尺寸: M10 x P1.5, L: 25 mm

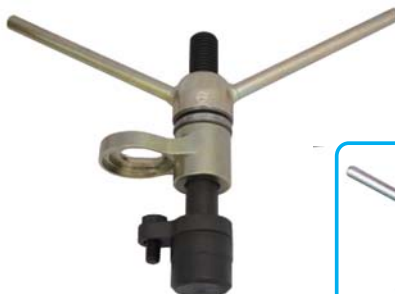

VIDEO







011

HWANG CHERNG BIN  
Specialty Tools Inc.

歐系卡車修護工具

European Truck Repair Tool



European Truck  
Repair Tool(SCANIA)

### H.C.B-A1630

**NEW**

### SCANIA(114) INJECTOR REMOVAL/ INSTALLATION TOOL KIT

SCANIA (114) 噴油嘴拆裝工具組

- This tool has the single hook design. When removing the injector, only one hook is required. Use the slide hammer to remove the injector without damaging the injector or relative parts. It is a saving-time and saving-labor tool.
- Application: SCANIA (114) 340.360.380
- 此工具之爪鉤為單邊設計。拆卸時只需單邊勾住噴油嘴，之後利用滑鏈即可將其取出。過程中不會損害噴油嘴及相關零件，快速又方便。
- 適用車種：SCANIA (114) 340.360.380



### H.C.B-A2228

### SCANIA SOCKET (Dr. 3/4", 90 mm) (E28)

SCANIA 套筒 (Dr. 3/4", 90 mm) (E28)

- To remove / install the bolt of crankshaft main bearing cap.
- Application: SCANIA Ti engine.
- 可拆裝曲軸主培林蓋上的螺絲。
- 適用車種：SCANIA Ti引擎



### H.C.B-A1353

### KNORR-BREMSE DISC BRAKE SERVICE KIT

卡車碟煞 (KNORR-BREMSE) 維修組

- A complete service kit for Knorr-Bremse disc brake set.
- Series of disc brake: SN6 / SN7 / SK7 / ADB22X
- Applicable: Most of European trucks. Such as : SCANIA, VOLVO...etc.
- 維修Knorr-Bremse碟式煞車的完整工具組。
- 適用煞車系列：SN6 / SN7 / SK7 / ADB22X
- 適用車種：大部份的歐系卡車。例如：SCANIA，VOLVO...等。

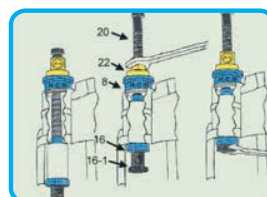
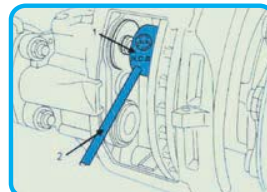

### H.C.B-B1353

### CALLIPER ADJUSTER SOCKET (H24, 5 TEETH)

卡鉗調整器套筒 (H24, 5齒)

- To combine with A1353.
- Size: H24, 5 teeth, 46 mm/L
- Material: SCM440
- 搭配 A1353一起使用。
- 尺寸: H24, 5齒, 46 mm/L
- 材質: SCM440





## H.C.B-A2193

## DIESEL INJECTOR PULLER

柴油噴油嘴拆卸器



20 / 24 / 24.5 / 1.38"

- Assist to remove stubborn BOSCH and LUCAS diesel injectors for saving time.
- With M8, M12, M14 adapters M8 x P 0.75 / M12 x P 1.5 / M14 x P 1.5
- Application : VOLVO, SCANIA (ex. 113 (320))
- 協助拆卸卡緊的BOSCH和LUCAS柴油噴油嘴，可節省時間。
- 有M8，M12，M14三種接頭 M8 x P0.75 / M12 x P1.5 / M14 x P 1.5
- 適用車種：VOLVO，SCANIA(例如：113 (320))



Model : VOLVO, SCANIA (M14xP1.5)



Model : BOSCH (M12xP1.5)

## H.C.B-A1444

## SCANIA TRUCK (310/320) REAR WHEEL AXLES HUB REMOVER

SCANIA (310/320) 卡車後輪HUB拔卸器

### VIDEO



- SCANIA axle bearing will be stuck when it's over heat, so use H.C.B-A1444 with wrench to solve this problem.
- Application: SCANIA (310/320) REAR WHEEL AXLE HUB.
- 當SCANIA卡車輪軸承過熱咬死，使用此工具搭配氣動扳手拆卸的更輕鬆、容易
- 適用車種：SCANIA (310/320) 卡車後輪HUB



1 Firstly, Scania rear wheel nut (Dr.3/4", 8 POINTS, 100mm) should be extracted.

2 Use H.C.B-B1126 to extract scania rear wheel nut before using A1444



3 Put center fix plate of A1444 on hub

4 Finally, use A1444 with wrench to extract scania (310/320) rear wheel axle hub

## H.C.B-A1478

## SCANIA 310 (112) & 320 (113) EXTRACTOR

SCANIA 310(112)&320(113) 傳動軸接座 & 曲軸油封接座拔卸器

- When SCANIA truck front crankshaft oil seal connector base and propeller shaft connector base are overheated, use H.C.B-A1478 with air wrench to replace oil seal.
- Instruction:  
Put H.C.B-A1478-1 main plate onto holes of front crankshaft oil seal connector base or propeller shaft connector base, and fix screws, turning the center screw bar to remove oil seal.
- Save time and labor, it is your best choice!
- Application: SCANIA 310 (112) 320 (113) Truck
- 當SCANIA卡車前曲軸油封接座或傳動軸接座過熱咬死，使用此工具搭配氣動扳手拆卸，即可拆卸更換油封。
- 將拆卸盤對準前曲軸油封接座或傳動軸接座孔，將螺絲固定鎖緊後，再轉動中心螺桿即可取出。
- 既省力又方便有效率，是您賺錢的最佳利器。



Parts No.	Description	Specification
1	Main Plate	H46 ø200x L36
2	Center screw bar	H30 TM30W6 L283
3	Center top block	ø58xL20
4	Fixing screw	H19 M12xP1.75 xL55
5	Fixing screw	H19 M12xP1.75 xL40



European Truck Repair Tool(SCANIA)

## H.C.B-A1490

## SCANIA 113 (10 SPEED) TRANSMISSION MAINSHAFT/ COUNTERSHAFT/ INPUT SHAFT BEARING PULLER

SCANIA 113 (10速) 變速箱主軸/副軸/輸入軸 培林拆卸器

- Formerly, engineers extract the bearings by damaging the bearing. It might damage the part and the shaft. Use this tool can extract the five bearings easily and Won't damage the parts.
- The best tool for removing SCANIA 113 transmission bearing.
- Application: SCANIA 113
- 此工具可拆卸變速箱的主軸、副軸與輸入軸的培林
- 以往若無使用工具，會使用破壞性方法來拆卸培林，這樣容易損害到零件，使用此工具可以輕鬆拆卸變速箱的主軸、副軸與輸入軸的5個培林，過程中不會損害到相關零件
- 適用車種: SCANIA 113



**This tool can extract the five bearing of the shaft**  
此工具可拆卸5個培林

Genuine no.: 284997  
Mainshaft (rear) bearing no. 39580128  
主軸(後)培林號碼 (39580128)

Genuine no.: 284992  
Countershaft (rear) bearing no. 4821472  
副軸(後)培林號碼 (4821472)

Genuine no.: 1121538  
Bearing no. 575 1 572X  
培林號碼 (575 1 572X)

Genuine no.: 284843  
Mainshaft (front) bearing no. 33208  
主軸(前)培林號碼 (33208)

Genuine no.: 317350  
Countershaft (front) bearing no. 405110149  
副軸(前)培林號碼 (405110149)

## H.C.B-B1490

**NEW** SCANIA 113 (10 SPEED) TRANSMISSION MAINSHAFT/ COUNTERSHAFT/ INPUT SHAFT BEARING INSTALLER

SCANIA 113 (10速) 變速箱主軸/副軸/輸入軸培林安裝工具

- The best tool for installing SCANIA 113 transmission bearing.
- Won't damage the bearing and related parts.
- Application: SCANIA 113 10 speed transmission
- 不會損壞培林或相關零件
- 方便使用，省時又省錢
- 適用車種: SCANIA 113 10速變速箱



## H.C.B-C1490

**NEW** SCANIA 113 (10 SPEED) TRANSMISSION MAINSHAFT/ COUNTERSHAFT/INPUT SHAFT BEARING REMOVAL/ INSTALLATION TOOL

SCANIA 113 (10速) 變速箱主軸/ 副軸/ 輸入軸 培林拆裝工具

- Formerly, engineers extract the bearings by damaging the bearing. It might damage the part and the shaft. Use this tool can extract and install the five bearings easily and won't damage the parts.
- Application: SCANIA 113
- 此工具可拆卸、安裝變速箱的主軸、副軸與輸入軸的培林。
- 以往若無使用工具，不易拆裝，過程耗時許多時間與人力，使用此工具可以輕鬆拆卸、安裝變速箱的主軸、副軸與輸入軸的5個培林，過程中不會損害到相關零件，可搭配油壓工具來使用。
- 適用車種: SCANIA 113







### H.C.B-D1391

### SCANIA REAR WHEEL HUB INNER BEARING EXTRACTOR

SCANIA後輪軸內側培林拔卸器

- Application: All SCANIA truck.
- Feature: This tool is designed to extract SCANIA rear wheel hub inner bearing. With this tool, you can remove the bearing quickly and easily.
- 適用車種: **SCANIA**全車系
- 說明:此工具用來拔除**SCANIA**後輪內側培林，讓您在拔除培林的過程更加快速，方便。



VIDEO

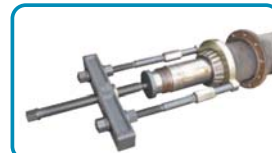

### H.C.B-E1391

### SCANIA REAR WHEEL HUB INNER BEARING INSTALLER

SCANIA 後輪軸內側培林安裝器

- Application: All SCANIA truck.
- Feature: This tool is designed to install SCANIA rear wheel hub inner bearing. With this tool, you can install the bearing quickly and easily.
- 適用車種: **SCANIA**全車系
- 說明:此工具用來安裝**SCANIA**後輪內側培林，讓您在安裝培林的過程更加快速、方便。



VIDEO



拿鐵鎚敲打工具的前端.直至培林安裝完成

Use hammer hit the front of the tool until bearing install finish.



培林安裝完成!  
Finish installing.

### H.C.B-A1050-2

### BPW TRAILER REAR WHEEL SOCKET (12 TONS) (H41, OVAL, 111 mm)

BPW 板車輪軸蓋拆裝套筒(12噸)(H41, 橢圓, 111mm)

10 / 29.5 / 30 / 0.91'

- For extracting the rear axle cover.
- Application: BPW 12 tons
- 可拆裝後輪軸蓋的套筒。
- 適用車種：BPW 12噸



### H.C.B-B1050-2

### BPW TRAILER REAR WHEEL SOCKET (6.5~9 TONS) (Dr. 3/4", OVAL, 95 mm)

BPW 板車輪軸蓋拆裝套筒(6.5~9噸)(Dr. 3/4", 橢圓, 95mm)

10 / 20.5 / 21.5 / 0.56'

- For extracting the rear axle cover.
- Application : BPW 6.5~9 tons
- 可拆裝後輪軸蓋的套筒。
- 適用車種：BPW 6.5~9噸

Dr. 3/4"







**011**  
**HWANG CHERNG BIN**  
 Specialty Tools Inc.

歐系卡車修護工具  
 European Truck Repair Tool



European Truck  
 Repair Tool (BPW)

**H.C.B-A1050-3** **BPW TRAILER REAR WHEEL SOCKET (FORMER 16 TONS) (H41, 8 POINTS, 120 mm)**

BPW 板車輪軸蓋拆裝套筒(舊型16噸) (H41, 8角, 120 mm)

**8 / 23.2 / 25.2 / 0.92'**





**H.C.B-B1050-3** **BPW TRAILER REAR WHEEL SOCKET (NEW 16 TONS) (Dr. 3/4", 8 POINTS, 110 mm)**

BPW 板車輪軸蓋拆裝套筒(新型16噸) (Dr. 3/4", 8角, 110 mm)

**8 / 25.5 / 26.5 / 1.27'**

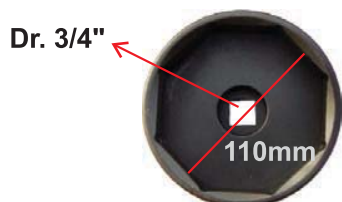
- Socket for the rear axle cover.
- 可拆裝後輪軸蓋的套筒

**H.C.B-B1050-3**

Item No.	Size	Model	
H.C.B-A1050-3	120mm	Former BPW 16T	H41
H.C.B-B1050-3	110mm	New BPW 16T	Dr. 3/4"

**H.C.B-A1050-4** **BPW TRAILER REAR WHEEL SOCKET (12 TONS) (H41, 8 POINTS, 109 mm)**

BPW 板車輪軸蓋拆裝套筒(12噸) (H41, 8角, 109 mm)

**8 / 18.4 / 20.2 / 0.75'**

- Socket for the rear axle cover.
- Application : BPW 12 tons
- N.W.: 2.9 KGS
- 可拆裝後輪軸蓋的套筒。
- 適用車種 : BPW 12噸
- 淨重 : 2.9公斤







**H.C.B-A1050-6** **BPW TRAILER REAR WHEEL SOCKET (12 TONS) (Dr. 1", OVAL, 111 mm)**

BPW 板車輪軸蓋拆裝套筒(12噸) (Dr. 1", 橢圓, 111 mm)

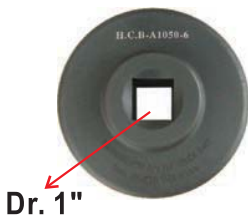
**8 / 21.5 / 23 / 0.88'**

- Socket for the rear axle cover.
- 可拆裝後輪軸蓋的套筒。

**VIDEO**





### H.C.B-B1050-6

### BPW TRAILER REAR WHEEL SOCKET (12 TONS) (Dr. 1", OVAL, 108 mm)

BPW 板車輪軸蓋拆裝套筒(12噸) (Dr. 1", 橢圓, 108 mm)

- Size: Dr. 1", OVAL, 108mm
- Application: BPW 12 Tons trailer
- 尺寸: Dr.1", 橢圓, 108mm
- 適用車種: BPW 12 噸板車



- Aftermarket wheel shaft cover from China
- 大陸製輪軸蓋

### H.C.B-C1050-6

### BPW TRAILER REAR WHEEL SOCKET (13~14 TONS) (Dr. 1", OVAL, 120 mm)

BPW 板車輪軸蓋拆裝套筒(13~14噸) (Dr.1", 橢圓, 120 mm)

- Size: Dr. 1", OVAL, 120 mm
- Application: BPW13~14 Tons trailer ( from 11/2004)
- 尺寸: Dr.1", 橢圓, 120 mm
- 適用車種: BPW13~14 噸板車 (從11/2004)



### H.C.B-D1050-6

### BPW TRAILER REAR WHEEL SOCKET (Dr.1", 109 mm)

BPW 板車輪軸蓋拆裝套筒 (Dr.1", 109 mm)

- Application: BPW 12 Tons trailer
- Size: Dr. 1", 109 mm
- 適用車種: BPW 12噸板車
- 尺寸: Dr.1", 109 mm



### H.C.B-A1066-1

### BPW 12 TONS AXLE EXTRACTOR (M125 x P2.0)

BPW 12噸輪軸拔取器 (M125 x P2.0, 外牙)

6 / 29 / 30 / 2.2'

- Specification: M125 x P2.0
- Screw specification: TM30 x W6
- For former 12 tons trailer
- 規格: M125 x P2.0
- 螺絲規格: TM30 x W6
- 適用於舊型12噸拖車

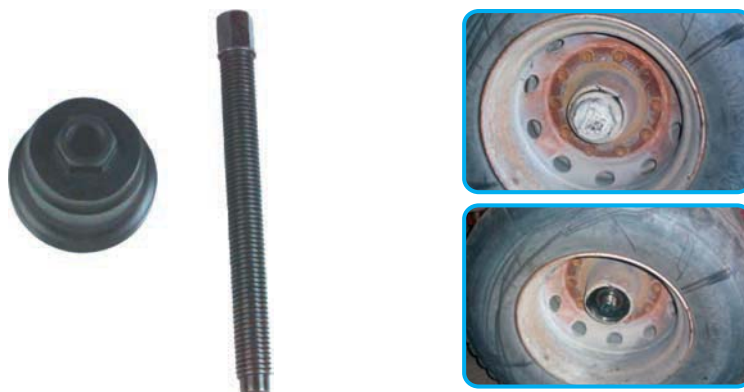



011

HWANG CHERNG BIN  
Specialty Tools Inc.

歐系卡車修護工具

European Truck Repair Tool



European Truck  
Repair Tool(BPW)

### H.C.B-A1066-2

### BPW 16 TONS AXLE EXTRACTOR (M155 x P3.0)

BPW 16噸輪軸拔取器 (M155 x P3.0, 外牙)

4 / 23 / 24 / 1.65'

- Specification: M155 x P3.0
- Screw specification: TM30xW6
- 規格: M155 x P3.0
- 螺絲規格: TM30 x W6



### H.C.B-A1066-3-1

### BPW 12 TONS AXLE EXTRACTOR (M135 x P2.0)

BPW 12噸輪軸拔取器 (M135 x P2.0, 內牙)

4 / 30 / 31 / 1.65'

- Specification: M135 x P2.0
- Screw specification: TM30xW6
- Application: BPW ECO 10~12 tons old model
- 規格: M135xP2.0
- 螺絲規格: TM30xW6
- 適用車種: BPW ECO 10~12噸舊型拖車



### H.C.B-A1066-3-2

### BPW 12 TONS AXLE EXTRACTOR (M136 x P2.5)

BPW 12噸輪軸拔取器 (M136 x P2.5, 內牙)

- Specification: M136 x P2.5
- Screw specification: TM30xW6
- Application: BPW ECO Plus 8~12 tons, BPW ECO 10 tons new model
- 規格: M136xP2.5
- 螺絲規格: TM30 x W6
- 適用車種: BPW ECO Plus 8~12噸、BPW 10噸新型拖車



### H.C.B-A1171

### BPW 12 TONS ROLLER AXLE NUT SOCKET (Dr. 3/4")

BPW 12噸板車輪軸螺母套筒(Dr.3/4")

Dr. 3/4"



BPW Code No.:  
03.266.47.03.0

Dimension:  
M 52 x 2 / SW 80



### H.C.B-B1171

### BPW 6.5~9 TONS ROLLER AXLE NUT SOCKET (Dr. 3/4")

BPW 6.5~9噸板車輪軸螺母套筒  
(Dr. 3/4")

12 / 9.96 / 11 / 0.78'

Material(材質):SCM 440  
Hardness(硬度): 45°-50°

Dr. 3/4"

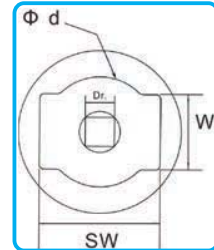

- Removes the lid of axle on BPW 12 tons / 6.5~9 tons with H.C.B-A1050-2 / H.C.B-B1050-2 before using this tool.
- H.C.B-A1171 / H.C.B-B1171 is for removing the fixed nut then replace the new bearing with adjustable torque wrench. Please follow the standard operation manual of origin.
- 更換BPW 12噸 / BPW 6.5~9噸拖車後輪培林前，必須先用H.C.B-A1050-2 / H.C.B-B1050-2拆下輪軸蓋。
- 使用H.C.B-A1171 / H.C.B-B1171拆下固定螺帽、更換新培林，並配合扭力扳手一起使用。(請遵照原廠規範操作)

Item No.	SW	W	φ d	Dr.
H.C.B-A1171	80mm	50mm	73mm	3/4"
H.C.B-B1171	64.5mm	40mm	61mm	3/4"
H.C.B-C1171	85mm	52mm	81.5mm	3/4"

### H.C.B-C1171

### BPW 13~14 TONS ROLLER AXLE NUT SOCKET (Dr. 3/4")

BPW 13~14噸板車輪軸螺母套筒(Dr. 3/4")

- Removal the lid of axle on BPW 12 tons trailer with H.C.B-A1050-2 before use this tool.
- Material : SCM440
- HRC : 45°-50°
- To remove the fix nut then replace the new bearing with adjustable torque wrench. Please follow the standard operation manual of origin.
- 更換BPW 12噸卡車後輪軸承必須先使用H.C.B-A1050-2拆下輪軸蓋。
- 使用拆下固定螺帽，更換新軸承並配合扭力扳手，按照原廠規範操作。
- 材質：SCM440
- 硬度：45°-50°



Dr. 3/4"



BPW CODE NO.: D-03.262.17.19.0



### H.C.B-A1281

### BPW 16 TONS ROLLER AXLE NUT SOCKET (Dr. 3/4", 6 POINTS, 85 mm)

BPW 16噸輪軸螺母套筒(Dr. 3/4", 6角, 85mm)

- To remove the nut then replaces the new bearing with adjustable torque wrench.  
(Please follow the standard operating manual of origin.)
- 和扭力扳手一起使用，以移除螺母並更換新培林。  
(請遵照原廠規範操作)

Dr. 3/4"



Dimension: SW 85 mm



011

HWANG CHERNG BIN  
Specialty Tools Inc.

歐系卡車修護工具

European Truck Repair Tool



European Truck  
Repair Tool(MAN)

### H.C.B-A1071

### MAN (422/403), BENZ TRUCK DIESEL INJECTION VALVE SOCKET

MAN (422/403), BENZ卡車柴油噴油嘴專用套筒

48 / 8.16 / 10 / 0.67'

- To remove and install diesel injection valve.
- Application: MAN 422/403, BENZ truck, SCANIA
- 移除和安裝柴油噴油嘴。
- 適用車種：MAN 422/403，BENZ卡車，SCANIA



### H.C.B-A1075

### MAN FRONT WHEEL HUB EXTRACTOR

MAN 卡車前輪HUB拔卸器

4 / 17 / 17.5 / 1.38'

- For removing the front wheel hub.
- Application: MAN truck
- Specification: M115 x P1.5
- 用來拔卸前輪HUB。
- 適用車種：MAN卡車
- 規格：M115 x P1.5



### H.C.B-B1075

### MAN FRONT WHEEL HUB INSTALLER

MAN 卡車前輪HUB安裝器

- For installing front wheel hub of MAN.
- There is a bearing inside the tool, to save effort.
- Specification: M40 x P1.5

- 安裝MAN卡車前輪HUB。
- 工具內附加培林更省力、安全便利。
- 內牙尺寸：M40xP1.5

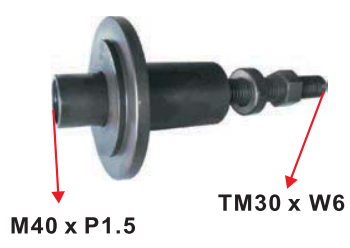

### H.C.B-A1172

### MAN AXLE BEARING EXTRACTOR

MAN 卡車輪軸培林拆卸器

2 / 17.7 / 19 / 1.47'

- For replacing MAN truck hub bearings and removing the old bearings.
- Turn the screw to remove the bearing

- 更換MAN卡車Hub培林及拆卸舊培林的必備工具
- 只需轉動螺絲便可拆卸培林

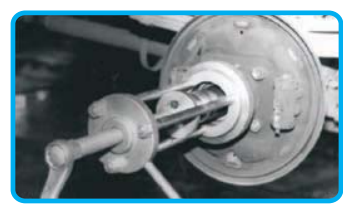

## H.C.B-B1172

## MAN TRACTOR (33460/410/414) AXLE BEARING EXTRACTOR

MAN 卡車前輪 (33460/410/414) 輪軸培林拆卸器

- Best tool for replacing MAN tractor hub bearings and removing the old bearings.
- Turn the screw and remove the bearing.
- Application: MAN truck tractor 33460/410/414 with front disc brake bearing.
- 更換MAN拖車頭HUB培林及拆卸培林的必備工具
- 只需轉動螺絲便可拆卸培林
- 適用車種：MAN 拖車頭33460/410/414前碟剎輪軸培林



No. 331933 / Q  
No. FGA 575194  
AUSTRALIA 149A A



## H.C.B-A1203

## MAN TRUCK DIFFERENTIAL BEARING EXTRACTOR

MAN 卡車差速器培林拔卸器

- For replacing MAN differential bearing and removing the old bearings.
- Turn the screw to remove the bearing
- 用來移除舊MAN差速器培林，並更換新培林。
- 轉動螺桿來移除培林。



No. FAG 801400A  
AUSTRIA Z.A1/3



No. FAG 32024X AUSTRIA 013 Y.A

## H.C.B-A1228

## MAN TRUCK TRANSMISSION SOCKET (Dr. 3/4")

MAN 卡車變速箱專用套筒 (Dr. 3/4")

- Application: MAN 410/414
- 適用車種：MAN 410/414

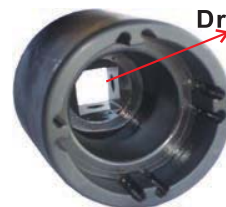

Dr. 3/4"

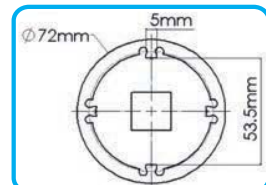

## H.C.B-A1273

## MAN (FE410A / FE414) PITMAN ARM PULLER (Dr. 3/4", 67 mm)

MAN (FE410A / FE414) 卡車方向機搖臂拆卸器 (Dr. 3/4", 67 mm)

5 / 23 / 23.5 / 0.74"

- The tool is designed for extracting pitman arm of MAN. It's different from traditional. This one can prevent pitman arm from damage.
- Use H6, 70 mm socket to remove the fixed nut on the pitman arm before using this tool.
- Application: MAN tractor trailer FE410A, FE 414.
- 本工具設計用來拆卸MAN的搖臂。和傳統的工具不同，本工具可以避免損害搖臂。
- 使用本工具之前，請用H6，70mm的套筒移除搖臂上的固定螺帽。
- 適用車種：MAN拖車FE410A，FE 414



To loosen the fixed nut on the arm before using A1273



Dr. 3/4"







011

HWANG CHERNG BIN  
Specialty Tools Inc.

歐系卡車修護工具

European Truck Repair Tool



European Truck  
Repair Tool(MAN)

### H.C.B-A1274

### MAN (FE410A) STEERING MECHANISM OIL SEAL SOCKET (Dr. 1/2", 4 POINTS)

MAN (FE410A) 卡車方向機油封套筒 (Dr. 1/2", 4點)

- To replace steering mechanism oil seal by loosening tightening the nut.
- It might damage the related parts while replacing the oil seal without this tool.
- Application: MAN tractor FE410A
- 藉由鬆開/鎖緊螺帽，來更換油封。
- 更換油封時，若不使用本工具，有可能會損害相關零配件。
- 適用車種：MAN拖車FE410A

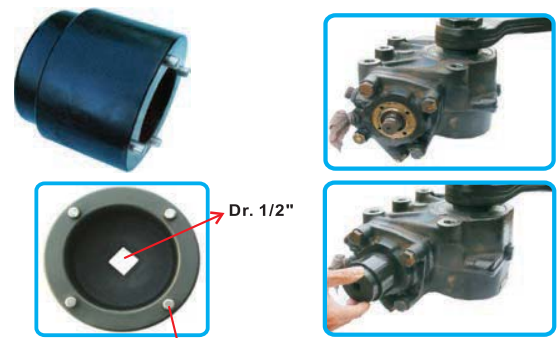

### H.C.B-A1239

### MAN TRUCK FRONT WHEEL HUB REMOVER

MAN 卡車前輪HUB拆卸器

- When MAN axle bearing is stuck due to overheating , use this tool with air wrench for labor saver and easier removal.
- P.C.D. is  $\phi$ 166 mm
- Application: MAN new type truck
- 當MAN輪軸因為過熱而卡死，可用本工具配合氣動扳手來 拆卸前輪HUB。省時又省力。
- P.C.D:  $\phi$  166 mm
- 適用車種：MAN(新型)卡車



### H.C.B-A1328

### MAN TGA FRONT WHEEL AXLE NUT SOCKET (Dr. 3/4", H60, 93 mm)

MAN TGA卡車前輪軸&後輪舉升軸螺帽套筒 (Dr. 3/4", H60, 93 mm)

10 / 27.5 / 28.5 / 0.74'

- Fix bearing while removing or installing the truck nut.
- Use the air wrench or rod to control the nut to tighten or loosen bearing.
- Application: MAN-TGA front wheel
- 移除或安裝卡車前輪螺帽時，需使用本工具固定來培林。
- 使用氣動扳手或扳桿來控制螺帽，以鎖緊或鬆開培林。
- 適用範圍：MAN-TGA前輪軸&後輪舉升軸 (410/414/640)



### H.C.B-A1329

### MAN TGA DRIVE AXLE NUT SOCKET (Dr. 3/4", H60, 158 mm)

MAN TGA 卡車帶動軸螺帽套筒 (Dr. 3/4", H60, 158 mm)

4 / 18.5 / 19.5 / 1.64'

- Fix bearing while removing or installing the truck nut.
- Use the air wrench or rod to control the nut to tighten or loosen bearing.
- Application: MAN-TGA (410/414/460)drive axle
- 移除或安裝卡車帶動軸螺帽時，需使用本工具來固定培林。
- 使用氣動扳手或扳桿來控制螺帽，以鎖緊或鬆開培林。
- 適用範圍：MAN-TGA (410/414/460)帶動軸

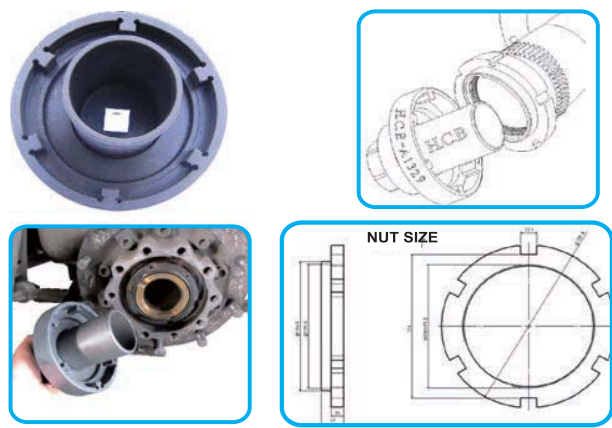



### H.C.B-A1344

### MAN, BENZ DIFFERENTIAL REAR NUT SOCKET (Dr. 3/4", 6 TEETH)

MAN, BENZ 卡車差速器後螺母套筒 (Dr. 3/4", 6 齒)

6 / 25 / 26 / 0.74"

- For removing the differential rear nut.
- Application: MAN, Benz truck
- 用來移除差速器後螺母。
- 適用車種：MAN, Benz卡車

Specification / 規格：

Teeth / 齒數	6	
Size of tooth / 尺寸	8.7 mm	
Inner Diameter / 內徑	Tooth to tooth / 齒對齒	113 mm
	Side to side / 邊到邊	126 mm

Dr. 3/4"

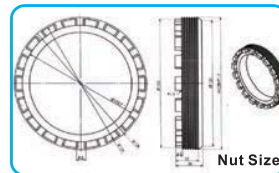

### H.C.B-A1345

### MAN, BENZ DRIVE AXLE NUT SOCKET (Dr. 3/4", H60, 6 TEETH)

MAN, BENZ 卡車帶動軸螺母套筒 (Dr. 3/4", H60, 6 齒)

6 / 18 / 19 / 0.74"

- For removing the drive axle nut.
- Application: MAN, Benz truck
- 用來移除帶動軸螺母。
- 適用車種：MAN, Benz卡車

Specification / 規格：

Teeth / 齒數	6	
Size of tooth / 尺寸	11.5 mm	
Inner Diameter / 內徑	Tooth to tooth / 齒對齒	102 mm
	Side to side / 邊到邊	111 mm

Dr. 3/4"

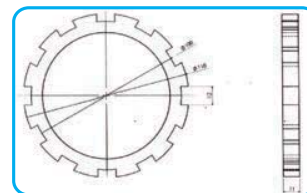

### H.C.B-A2018-19

### MAN TRUCK OIL FILTER WRENCH (Dr. 1/2", 18 POINTS, 135 mm)

MAN 卡車機油芯扳手 (Dr. 1/2", 18角, 135 mm)

- Application: MAN truck. Series F2000, FE and TGA engine. (406, 410, 414, 440, 460)
- 適用車種：MAN 卡車。F2000, FE和TGA 引擎的車系。(406, 410, 414, 440, 460)

Dr. 1/2"

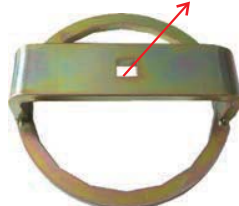



011

HWANG CHERNG BIN  
Specialty Tools Inc.

歐系卡車修護工具

European Truck Repair Tool



European Truck  
Repair Tool(VOLVO)

### H.C.B-A2132

### MAN STAR-E IMPACT SOCKET (Dr. 3/4", E18/E20) (FOR HGV CYLINDER-HEAD BOLT)

MAN 卡車星型衝擊式套筒(Dr. 3/4", E18/E20) (氣缸床用)

- Suitable for torque wrenches.
- Reinforced design.
- Chrome-Vanadium special steel / surface burnished.
- Dr. 3/4", 90 mm
- 可和扭力扳手一起使用。
- 強化型的設計。
- 材質：鉻釩鋼，表面拋光
- 規格：Dr. 3/4"，90 mm



H.C.B-A2132 **E18**  
On MAN commercial vehicles M2000 and MAN buses with D08 engines  
適用車種：MAN商務車M2000和搭載D08引擎的MAN遊覽車

H.C.B-A2132 **E20**  
On MAN commercial vehicles F2000, F90, F8 and MAN buses with D25 and D28 engines  
適用車種：MAN商務車F2000, F90, F8和搭載D25, D28引擎的MAN遊覽車

### H.C.B-B2132

### MAN STAR-E IMPACT SOCKET KIT (FOR HGV CYLINDER-HEAD BOLT)

MAN卡車星型衝擊式套筒組(氣缸床用)

- Suitable for impact wrenches
- Reinforced design
- Chrome-Vanadium special steel / surface burnished
- Dr. 3/4", 90 mm
- 可和扭力扳手一起使用。
- 強化型的設計。
- 材質：鉻釩鋼，表面拋光
- 規格：Dr. 3/4"，90 mm



Item No. 編號	Applicable 適用車種	Specification 規格
H.C.B-B2132-17	For Benz engines 400, 420 Benz引擎400, 420	Dr. 3/4", 12 points, 17mm Dr. 3/4", 12角, 17mm
H.C.B-B2132-19	For Benz engine 300, 400. Ex. ACTORS Benz引擎300, 400。例如：ACTORS	Dr. 3/4", 12 points, 19mm Dr. 3/4", 12角, 19mm
H.C.B-B2132-E18	For MAN commercial vehicles M2000 and MAN buses with D08 engine. MAN商務車M2000和搭載D08引擎的MAN遊覽車	Dr. 3/4", E18
H.C.B-B2132-E20	For MAN commercial vehicles F2000, F90, F8 and MAN buses with D25 and D28 engine. MAN商務車F2000, F90, F8和搭載D25, D28引擎的MAN遊覽車	Dr. 3/4", E20
H.C.B-B2132-E24	For MAN commercial vehicles with D20 engine. MAN搭載D20引擎的MAN商務車	Dr. 3/4", E24



### H.C.B-C2132

### MAN STAR-E IMPACT SOCKET SET (FOR HGV CYLINDER-HEAD BOLT) (6PCS) (E18/E20/E22/E24/17 mm/19 mm) (6 POINT)

MAN卡車星型衝擊式套筒組(氣缸床用)  
(6PCS) (E18/E20/E22/E24/17mm/19mm) (6角)

- For removing the cylinder head bolts from engines.
- Size: E18, E20, E22, E24, 17mm, 19mm. (12Points)
- Application: MB 300-400-420-500-900  
MAN M2000, F90, F8, D20, D25, D28
- E24 can use on MAN front/rear wheel cover
- 拆除汽缸頭螺絲
- 尺寸：E18, E20, E22, E24, 17mm, 19mm (12角)
- 適用車種：MB 300-400-420-500-900  
MAN M2000, F90, F8, D20, D25, D28
- E24可以用於MAN前後輪軸蓋







歐系卡車修護工具

European Truck Repair Tool



011

HWANG CHERNG BIN  
Specialty Tools Inc.



## H.C.B-B1102

EUROPEAN TRUCK BALL JOINT REMOVER (39 mm)  
PAT.M362085

歐系卡車球接頭拔卸器 (39 mm)

10 / 21.5 / 22.5 / 1'

- On car maintenance.
- The best tool for removing truck ball joint.
- No damage to ball joint and related parts.
- Easy to use. Save time and money.
- Specification: nut width 26 mm, bolt length 128 mm.
- Application: Over 4 tons and most of European trucks.  
For example SCANIA, BENZ, MAN, HINO, also can use for DAF PITMAN ARM DAF ...etc.
- Special for MAN 414 drag link.

- 免拆零件、車上維修。
- 拆卸球接頭的利器。
- 不會損壞球接頭及相關零件。
- 操作簡便。省時又省錢。
- 規格：螺帽寬-26 mm，螺桿長-128 mm。
- 適用車種：4噸以上及大部份的歐系卡車。例如：SCANIA，BENZ，MAN，HINO，也是可DAF方向機搖臂...等。
- 特別適用於MAN 414方向機直拉桿。

Window



Central ball of Bolt  
■ 鋼珠設計更堅固耐用



## H.C.B-A1169

VOLVO TRUCK FRONT / REAR BRAKE  
SHOE LINING INSIDE CALIPER

VOLVO 卡車前後輪煞車來令片更換卡鉗夾

10 / 18.7 / 20 / 1.69'

- Extend wider and hold open brake shoe steel by locking A1169 inside caliper closer. Take out the bolts and change new brake shoe lining.
- Application: VOLVO trucks. VOLVO N7, N10, N12, F7, F12, F16, FH12, FH16, FL7, FL10 ERF E Series and EC Series
- 更換VOLVO前、後輪煞車來令片前，必須先用此工具拆下固定銷。
- 適用車種：VOLVO N7, N10, N12, F7, F12, F16, FH12, FH16, FL7, FL10 ERF E 系列 and EC 系列



VIDEO



Genuine stock No.:  
VOLVO 9998550

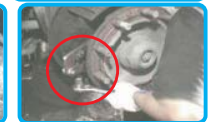
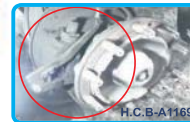

## H.C.B-A1175

VOLVO (MP7) FLYWHEEL TURNING TOOL

VOLVO (MP7) 卡車曲軸飛輪轉動器

10 / 8 / 9 / 0.71'

- This tool is designed for rotating crankshaft for timing
- 此工具藉由轉動曲軸飛輪來校正正時

Genuine Stock:  
VOLVO 9996956





011

HWANG CHERNG BIN  
Specialty Tools Inc.

歐系卡車修護工具

European Truck Repair Tool



European Truck  
Repair Tool(VOLVO)

### H.C.B-B1175

### VOLVO (MP8 / MP10) FLYWHEEL TURNING TOOL

VOLVO (MP8 / MP10) 曲軸飛輪轉動工具

- Remove plugs flywheel cover and place the rotation tool H.C.B-B1175.
- Application : Volvo truck (MP8 / MP10), (FH, D13A520)
- OEM no. ref.:88800014
- 藉由此工具轉動曲軸飛輪來校正正時.
- 適用車種: VOLVO 卡車 (MP8 / MP10), (FH, D13A520)
- 原廠號碼: 88800014

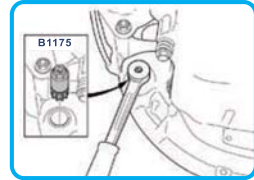
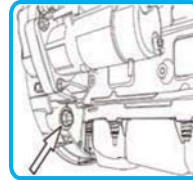

### H.C.B-A1176

### VOLVO WHEEL SHAFT COVER SOCKET (Dr. 3/4", 8 POINTS, 115 mm)

VOLVO 卡車輪軸蓋套筒 (Dr. 3/4", 8角, 115 mm)

8 / 21.5 / 22.5 / 0.85'

- Application: VOLVO FRONT AND REAR SHAFT COVER, RENAULT (After 2007)
- Size: 115 mm, 8 points
- 適用VOLVO前後輪蓋拆卸, 雷諾(2007以後)

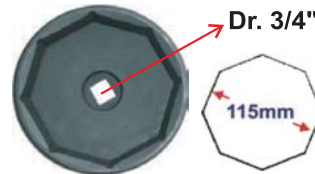

### H.C.B-A1186

### VOLVO SHOCK ABSORBER SPRING WASHER REMOVAL SOCKET (H27) (FRONT)

VOLVO 避震器彈簧墊片拆卸套筒 (H27)(前)

- Application: VOLVO e.g.FL6/F10/F12
- 適用車種: VOLVO 例如:FL6/F10/F12



### H.C.B-B1186

### VOLVO SHOCK ABSORBER SPRING WASHER REMOVAL SOCKET (Dr. 3/4") (REAR)

VOLVO 避震器彈簧墊片拆卸套筒 (Dr. 3/4") (後)

- Application: VOLVO rear axle e.g.FH
- 適用車種: VOLVO 例如:FH

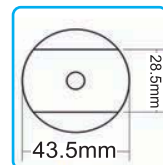



歐系卡車修護工具

European Truck Repair Tool



011

HWANG CHERNG BIN  
Specialty Tools Inc.



European Truck  
Repair Tool(VOLVO)

### H.C.B-A1229

### VOLVO (FM12) TRANSMISSION CLUTCH CALIPER PISTONS DEPTH LEVEL GAUGE

VOLVO (FM12) 卡車變速箱離合器分泵深度量規



### H.C.B-A1238

### VOLVO TRUCK AXLE NUT SOCKET (Dr. 3/4", 6 POINTS, 105 mm)

VOLVO 卡車輪軸螺帽套筒 (Dr. 3/4", 6角, 105 mm)

- Fix bearing while removing or installing the truck nut.
- Use the air wrench or rod to control the nut to tighten or loosen bearing
- 拆卸, 安裝卡車螺帽時, 用來固定培林
- 以氣動扳手或扳桿控制螺帽, 控制培林的鬆緊度



### H.C.B-B1238

### VOLVO TRUCK AXLE NUT SOCKET (Dr. 3/4", 6 POINTS, 95 mm)

VOLVO 卡車輪軸螺帽套筒 (Dr. 3/4", 6角, 95 mm)

- Fix bearing while removing or installing the truck nut.
- Control the nut with air wrench or rod to tighten or loose bearing.
- Application: VOLVO FH rear axle.
- 移除或安裝卡車輪軸螺帽時, 需使用本工具固定來培林。
- 使用氣動扳手或扳桿來控制螺帽, 以鎖緊或鬆開培林。
- 適用範圍: VOLVO卡車FH後輪軸



### H.C.B-A1246

### VOLVO TRUCK CAB SHOCK ABSORBER UPPER BASE NUT EXTRACTOR / INSTALLER

VOLVO 卡車車頭避震器上座螺帽拆裝器

- For extracting and installing the shock absorber upper base nut of VOLVO Truck
- Application: VOLVO Truck FL10/ FM12
- 用來拆裝避震器上座螺帽
- 適用車種: VOLVO卡車 (FL10) (FM12)



### H.C.B-A1247

### VOLVO TRUCK OIL FILTER WRENCH (Dr. 1/2", 15 POINTS, 107 mm)

VOLVO 卡車機油芯扳手 (Dr. 1/2", 15角, 107 mm)

- Genuine stock no.: 466634
- Application: VOLVO truck
- 原廠料號: 466634
- 適用車種: VOLVO卡車

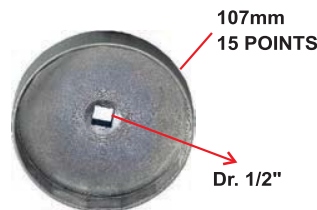





011

HWANG CHERNG BIN  
Specialty Tools Inc.

歐系卡車修護工具

European Truck Repair Tool



European Truck  
Repair Tool(VOLVO)

### H.C.B-A1269

### SCANIA / VOLVO TRUCK CAB REMOVAL WRENCH (12 POINTS, 22 mm)

SCANIA /VOLVO 拖車頭拆卸扳手  
(12角, 22 mm)



Hydraulic Valve Switch



Turning on / off Hydraulic Valve Switch



Cab-Lift Hydraulic Valve Adjust Screw



Rotating Cab-Lift Hydraulic Valve Adjust Screw

- Apply park, brake. Gear in neutral. Close the doors.
- Before lifting up the cab, turn on hydraulic valve switch with anti-clockwise. Rotating cab-lift hydraulic valve adjust screw with socket, and then lifting the cab gradually.
- When restoring the cab, turn off hydraulic valve switch with clockwise to position. Rotating cab-lift hydraulic valve adjust screw with socket, and then reinstate the cab gradually.
- Application: VOLVO FM12/ FL10/ FH500/ FM 440,SCANIA 340(114)
- 拉起煞車、放空檔、關好車門。
- 要舉起車頭之前，先逆時針轉動油壓閥開關，再用本工具旋轉油壓閥調整螺絲，慢慢抬起車頭。
- 完成維修後，順時針旋轉油壓閥調整螺絲，慢慢放下車頭。
- 適用車種：VOLVO FM12 / FL10 / FH500 / FM440, SCANIA 340 (114)

### H.C.B-A1335

### VOLVO (FM12) KING PIN UPPER COVER SOCKET (Dr. 3/4", 6 POINTS, 80 mm)

VOLVO (FM12) 卡車大王銷上蓋套筒 (Dr. 3/4", 6角, 80 mm)

- For removing king pin upper cover.
- Specifications : Dr. 3/4", 6 points, 80 mm
- Application: VOLVO FM12
- 用來拆卸大王銷上蓋。
- 規格：Dr. 3/4"，6角，80 mm
- 適用車種：VOLVO卡車FM12



### H.C.B-B1350

### VOLVO RADIATOR ADAPTOR

VOLVO 卡車水箱快速接頭

- Female adaptor for radiator when purge or refill radiator liquid.
- Application: VOLVO trucks.
- Genuine no.:9996049
- 可用於排空和灌注水箱水的快速接頭。
- 適用車種：VOLVO卡車。
- 原廠料號：9996049

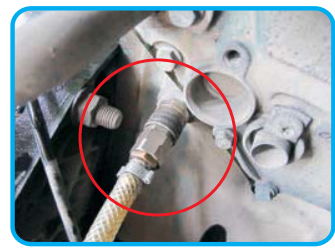



歐系卡車修護工具

European Truck Repair Tool



011

HWANG CHERNG BIN  
Specialty Tools Inc.



European Truck  
Repair Tool(VOLVO)

### H.C.B-A1363

### VOLVO TRUCK KING PIN BEARING PULLER

VOLVO 卡車大王銷培林拆卸器

- For removing king pin bearing.
- Application for VOLVO truck new series after FM12.
- Genuine no.: 9998621
- Stock no. of bearing: SKF 2619334W
- 用來拆除大王銷培林
- 適用車種：VOLVO卡車FM12之後的新車種。
- 原廠編號：9998621
- 培林編號：SKF 2619334W



### H.C.B-A1380

### VOLVO TRUCK FAN BEARING BASE SOCKET (Dr. 1/2")

VOLVO 卡車風扇軸承底座套筒 (Dr. 1/2")

- This tool is designed for removing nut to replace bearing.
- Application: VOLVO Truck, specifically for FM 12
- 此工具是設計用來拆卸螺母更換培林
- 適用車種：VOLVO卡車，特別是FM12



### H.C.B-A1393

### VOLVO (FM12) TRUCK INJECTOR SLEEVE REMOVER / INSTALLER KIT

VOLVO (FM12) 噴油嘴銅套拆裝工具組

5 / 20.5 / 21.5 / 2.02'

VIDEO



- This tool is designed for installing and removing sleeve.
- This tool needs to combine with H.C.B-B1350.
- Application: VOLVO FM 12 Truck

- 工具是用來拆卸及安裝噴油嘴銅套
- 此工具要配合H.C.B-B1350一起使用
- 適用車種：VOLVO FM 12 Truck



A1393-1



A1393-2



A1393-3



PART NO.: 85124276  
零件型號：85124276



PART NO.: 85104134  
零件型號：85104314





011

HWANG CHERNG BIN  
Specialty Tools Inc.

歐系卡車修護工具

European Truck Repair Tool



European Truck  
Repair Tool(VOLVO)

### H.C.B-B1393

### VOLVO (FM12)TRUCK INJECTOR SLEEVE REMOVER/INSTALLER KIT

VOLVO(FM)噴油嘴銅套拆裝工具組



PART NO.:85104134  
零件型號:85104134



PART NO.: 85124276  
零件型號 : 85124276

VIDEO



Optional tools



Sleeve no: 21515329  
Optional tools can remove/  
install the sleeve.

Removal:

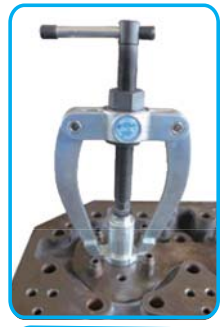
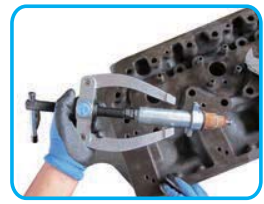

Install:



Application:VOLVO(FM)

Operation:

Removal:

Put the 2-1 puller into cylinder to reach sleeve.Screw top nut to make puller retain sleeve, then install 2-2 puller ring, and assemble No.1 puller ,screw top nut and take out the old sleeve.

Installation:

Put new sleeve into 3-1 expander,then install 3-2 thread tap, finally put the whole tool into cylinder, screw the top nut, then the new sleeve will be installed perfectly.

適用車種 : VOLVO(FM)

操作說明 :

拆卸：先將2-1號噴油嘴套筒擴張器，插入汽缸內至銅套，轉動上端螺母，使下方擴張器撐住銅套，再放入2-2 拆卸器墊塊，在接上1號拉拔器，轉動拉拔器上端螺母，即可將銅套取出。

安裝：將3-1噴油嘴套筒安裝工具本體前端放入銅套，再轉入3-2銅套固定桿，放入汽缸內到定位，再轉動上方螺母，即可固定銅套，安裝完成。

編號 NO.	品名 Description	原廠號碼 Original number
1	拉拔器 Puller	9986174
2-1	噴油嘴銅套擴張器 Puller	88800387
2-2	拆卸器墊塊 Puller ring	88800387
3-1	噴油嘴銅套安裝工具 Expander	
3-2	銅套固定桿 THREAD TAP	88880054

### H.C.B-A1402

### VOLVO (FM) VALVE SPRING COMPRESSOR TOOL KIT

VOLVO (FM) 氣門彈簧壓縮工具組

10 / 22 / 23 / 2.57'

- The size for the screw: M10 x P1.5, L: 25 mm
- To remove and install the valves of VOLVO trucks
- Application : VOLVO FM TRUCK
- Genuine no. : 9990210

- 螺絲尺寸 : M10xP1.5, L: 25mm
- 可移除和安裝卡車氣門彈簧來更換油封
- 適用車種 : VOLVO FM 卡車
- 原廠料號 : 9990210

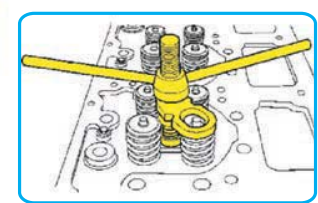
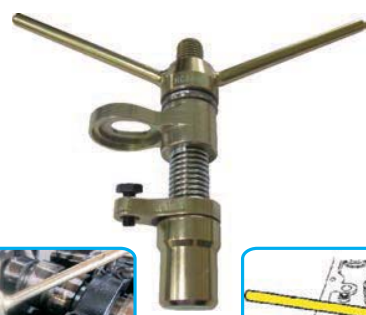





### H.C.B-A2018-3

### VOLVO TRUCK OIL FILTER WRENCH (Dr. 1/2", 15 POINTS, 107 mm)

VOLVO 卡車機油芯扳手 (Dr. 1/2", 15角, 107 mm)

30 / 16.8 / 18 / 1.49'

- For removing oil filter
- 用來拆除機油芯

Dr. 1/2"



European Truck  
Repair Tool(VOLVO)

### H.C.B-A1462

### VOLVO (FM/FH) INJECTOR NOZZLE PULLER

VOLVO (FM/FH) 噴油嘴拆卸工具

- This puller is designed to remove injector nozzles when injector pump is overheat and stuck.
- The slide hammer action gives a straight even pull without damaging components.
- Steps: (1)Open legs of main body and hook up with injector pump(2)then fix upper screw(3)take C base to fix with main body (4) assemble slide hammer to take out nozzle.
- Save time and Labor!
- Application:VOLVO FM12, FM, FH500 trucks.

- 當噴油嘴咬死難以拆卸時,使用此工具將可省時省力。
- 直立式滑槌設計於使用時不會傷及配件。
- 將工具本體兩側張開鉤在噴油嘴,並在將上方螺絲旋緊,之後將C型固定塊鎖緊,再接上滑槌撞擊,即可取出噴油嘴。
- 省時與省力,維修者的最佳利器!

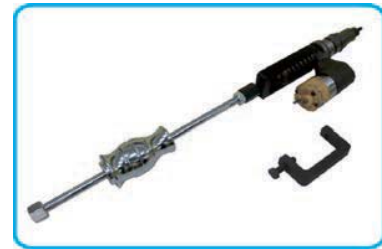

VOLVO Truck Fuel Injector Pump :3169521  
VOLVO 卡車 噴油嘴幫浦:3169521

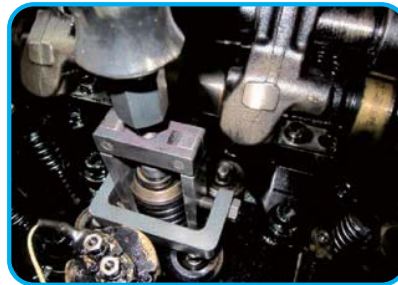

### H.C.B-A1423

### VOLVO (FM12) HYDRAULIC LIFT CYLINDER REMOVAL/INSTALLATION KIT

VOLVO (FM12) 舉升液壓缸拆裝工具

- This tool is designed for removing and installing the oil seal of hydraulic lift cylinder.
- Material : SCM 440
- Application: VOLVO (FM12) truck after 2005.
- 此工具設計用來拆裝液壓缸,來更換油封。
- 材質 : SCM 440
- 適用車種 : VOLVO(FM12) 2005年之後的車

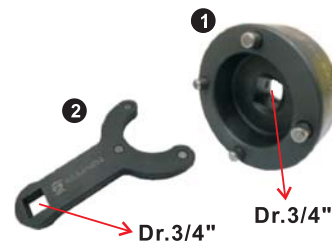



011

HWANG CHERNG BIN  
Specialty Tools Inc.

歐系卡車修護工具

European Truck Repair Tool



European Truck  
Repair Tool(VOLVO)

### H.C.B-F1560

NEW

### VOLVO (FM12) (EV90/EV91) TRUCK DIFFERENTIAL MAIN SHAFT BEARING EXTRACTOR

VOLVO (FM12) (EV90/EV91)卡車差速器主軸培林拆卸器

- Character: Normally, the removal of bearing is done by cutting, but it'll cause damage of main shaft. Using this tool kit can makes the removal of bearing done quickly, safely, and prevents the bearing from damage.
- Application: VOLVO (FM12) truck
- 說明: 傳統使用切割的方式拔除培林, 易損壞到主軸。使用此工具在拔除差速器的培林, 能快速、安全, 並保持培林不受損壞。
- 適用車種: VOLVO (FM12)卡車



VIDEO



Extract the top bearing



Bearing no.: 243150

### H.C.B-A1608

NEW

### VOLVO (FM12) (FM) (FH) STRAIGHT LINK BALL JOINT REMOVER

VOLVO (FM12) (FM) (FH) 直拉桿球接頭拆卸工具

- Feature: This ball joint is a special shape, the tool is with a special design to apply the ball joint.
- Instruction: The tool used to remove the end ball joint of the drag link of Volvo (FM12) (FM) (FH).
- Application: Volvo (FM12) (FM) (FH) truck.
- OEM no. ref: 9998758
- Operation: Put the tool to the ball joint, you can use air tool to turn the screw. Then the ball joint will be separated.
- 特色: 此球接頭形狀特別, 須有特殊工具才能拆卸此球接頭。
- 說明: 此工具為拆卸Volvo直拉桿後端球接頭。
- 操作: 將工具放置欲拆除位置, 可搭配氣動工具, 轉動螺桿直至球接頭分離。



VIDEO



⚠ Please remove the nut before you remove the ball joint.  
放置工具前, 請先拆除螺母!

### H.C.B-A1609

NEW

### VOLVO (FM/FH) MAIN SHAFT BEARING INSTALLER

VOLVO (FM/FH)差速器主軸培林安裝工具

- Instruction: Put the tools on the top bearing, Use hydraulic press push the tool. Then you can finish installing the bearing.
- OEM ref no.: 9996759
- Application: VOLVO FH/FM
- 說明: 將工具放置培林上放後, 利用油壓床將工具壓入, 即可完成安裝動作
- 原廠料號: 9996759
- 適用車種: VOLVO FH/FM

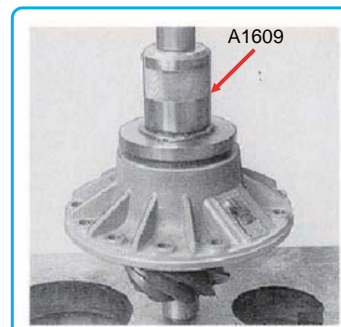

※ Please use with hydraulic press.





### H.C.B-A1614

**NEW**

### VOLVO (FM12) (FM) FRONT/REAR STABILIZER BALL JOINT REMOVER (43 mm)

VOLVO (FM12) (FM)  
前後平衡軸吊桿球接頭拆卸工具(43mm)

- Function: This remover is designed to remove the ball joints of front/rear stabilizer.
- Operation: Fit this remover on the ball joint, and turn the screw on the remover to push out the upper and lower ball joint.
- OEM No.: 9990814
- Application: VOLVO (FM12)(FM)



#### VIDEO



This remover allows the removal of both upper and lower ball joint of the stabilizer.

- 說明:此工具為拆卸前、後平衡軸吊桿的球接頭
- 操作:將工具放置球接頭位置後，轉動螺桿，即可拆卸上、下的球接頭
- 原廠號碼：9990814
- 適用車種：VOLVO (FM12) (FM)

Removal of upper ball joint



Removal of lower ball joint



### H.C.B-A1615

**NEW**

### VOLVO (FM) TRUCK ABS SENSOR WHEEL FITTING TOOL

VOLVO (FM)卡車ABS齒環安裝工具

- Feature : This tool can help you install the ABS sensor with even force. Avoid bad installation.
- Instruction : This tool designed to install ABS sensor. Without tool, it may appears ABS fault light if you did a bad installation.
- Application : VOLVO truck
- OEM ref no. : 9998558-3
- 特色：此工具在安裝ABS齒環時，齒環能平均受力，避免因施力不均導致安裝不良
- 使用說明：此工具用來安裝ABS感應器，若無使用此工具安裝，可能會造成汽車ABS故障燈亮起。
- 適用車種：VOLVO卡車
- 原廠料號：9998558-3

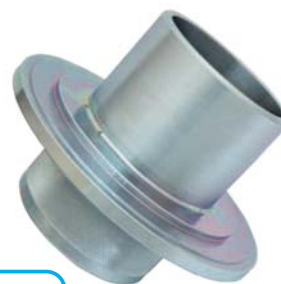

### H.C.B-A1616

**NEW**

### VOLVO TRUCK FITTING TIMING GEAR COVER INSTALLER

VOLVO卡車時規蓋安裝工具



- Feature : This tool is designed to fix gear cover. If you don't use this tools, it might cause gear cover leak oil.
- OEM ref no.: 9998389, 9998601
- 使用說明：此工具用是固定時規蓋時所需的工具。若無此工具，可能會導致時規蓋漏油。
- 原廠料號：9998389, 9998601

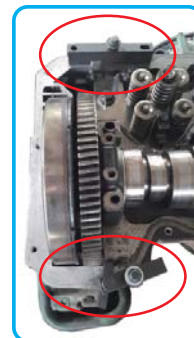





011

HWANG CHERNG BIN  
Specialty Tools Inc.

歐系卡車修護工具

European Truck Repair Tool



European Truck  
Repair Tool(VOLVO)

### H.C.B-A1617

**NEW**

### VOLVO TRUCK REMOVING AND FITTING TIMING GEAR PLATE TOOL

VOLVO卡車正時齒輪板工具

- Instruction: The tools are used to replace or repair components.
- Application: Volvo truck. Engine model: D12, D12A, D12B, D12C
- OEM no. ref.: 9998267
- 說明: 此工具可用來更換或修理零組件。
- 適用車種: VOLVO 卡車
- 原廠料號.: 9998267

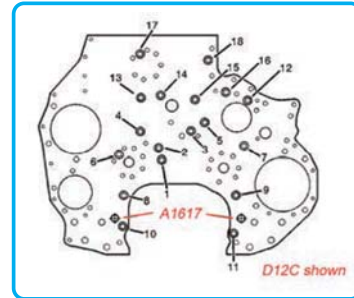

### H.C.B-A1626

**NEW**

### VOLVO (FM) TRUCK DISC BRAKE CALIPER FIXING SCREW WRENCH (Dr. 1")

VOLVO (FM)卡車碟煞卡鉗固定螺絲扳手(Dr. 1")

- Feature : This tool with different ends. One end is H27, it can work on the vehicle directly. The other end is Dr.1", you can lengthen it depending on the situation.
- Application : VOLVO (FM12) truck.
- OEM no. ref.: 9998573
- 特色: 此工具設計有兩邊不同尺寸, 一邊是H27, 可直接拆卸/安裝螺絲, 另一邊為Dr.1", 可視情況所需加長套筒。
- 適用車種: VOLVO (FM)卡車
- 原廠料號: 9998573



### H.C.B-A1627

**NEW**

### VOLVO (FM) TRUCK REAR WHEEL AXLE BEARING/ OIL SEAL INSTALLER

VOLVO(FM)卡車後輪軸培林/油封安裝工具

- Instruction : This tool can help you install the bearing or oil seal with even force. Avoid bad installation.
- Application : VOLVO(FM) truck.
- OEM no. ref.: 88800173
- 說明: 此工具用來安裝後輪軸培林及油封。在安裝培林或油封時, 能平均受力, 避免因施力不均, 導致安裝不良。
- 適用車種: VOLVO(FM)卡車
- 原廠料號: 88800173



### H.C.B-B1627

**NEW**

### VOLVO (FM) TRUCK FRONT WHEEL AXLE BEARING/ OIL SEAL INSTALLER

VOLVO(FM)卡車前輪軸培林/油封安裝工具

- Instruction : This tool can help you install the bearing or oil seal with even force. Avoid bad installation.
- Application : VOLVO(FM) truck.
- OEM no. ref.: F-566426
- 說明: 此工具用來安裝前輪軸培林及油封。在安裝培林或油封時, 能平均受力, 避免因施力不均, 導致安裝不良。
- 適用車種: VOLVO(FM)卡車
- 原廠料號: F-566426



H.C.B-C1627

NEW

VOLVO (FM) TRUCK LIFTING AXLE BEARING/  
OIL SEAL INSTALLER

VOLVO (FM)卡車舉升軸培林/油封安裝工具

- Instruction : This tool can help you install the bearing or oil seal with even force. Avoid bad installation.
- Application : VOLVO (FM) truck.
- OEM no. ref.: F-566426
- 說明：此工具用來安裝舉升輪軸培林及油封。在安裝培林或油封時，能平均受力，避免因施力不均，導致安裝不良。
- 適用車種：VOLVO (FM)卡車
- 原廠料號：F-566426



H.C.B-A1646

NEW

VOLVO (FM/FH) (12 SPEED) TRANSMISSION  
MAIN SHAFT BEARING/ GEAR REMOVAL TOOL

VOLVO (FM/FH) (12速) 變速箱主軸培林/齒輪拆卸工具

- Instruction:  
No.1 used to remove bearing of 12 speed transmission.  
No.2 used to remove gear of 12 speed transmission.
- Clamp is required while removing.
- Application: VOLVO truck (12 Speed)
- OEM no. ref.:9998215
- 使用方法:1號工具用來拆卸12速變速箱的培林  
2號工具用來拆卸12速變速箱的齒輪
- 必須配合夾具使用
- 適用車種: VOLVO卡車12速變速箱
- 原廠料號: 9998215



H.C.B-A1654

NEW

VOLVO (FM) FOR FITTING OUTPUT SHAFT SEAL

VOLVO (FM) 變速箱後油封安裝工具

- Feature: Use this tool can install transmission rear oil seal easily and conveniently.
- Application: VOLVO (FM) truck
- OEM no. ref.: 9998575
- 特色：此工具用來安裝變速箱後油封，輕鬆、快速就可安裝完成
- 適用車種：VOLVO (FM)卡車
- 原廠料號：9998575

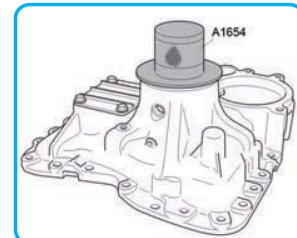

H.C.B-A1663

NEW

DAF (CF) 35 TONS DIFFERENTIAL FRONT/ REAR  
BEARINGS REMOVAL/ INSTALLATION TOOL

DAF (CF) 35噸差速器前後培林拆裝工具組

- Instruction: You can use this tool to remove and install the front/ rear bearing of DAF (CF) 35 tons truck differential.
- Application: DAF (CF) 35 tons truck.
- 說明：此工具可拆裝DAF (CF) 35 噸差速器的前後培林
- 適用車種: DAF (CF) 35噸卡車



Removal

Installation





011

HWANG CHERNG BIN  
Specialty Tools Inc.

歐系卡車修護工具

European Truck Repair Tool



European Truck  
Repair Tool(DAF)

### H.C.B-A1454

### DAF CF85 43 TONS TRAILER DRIVE SHAFT SOCKET(EURO 4 & EURO 5)(Dr.3/4")

DAF CF85 43 噸拖車頭傳動軸套筒  
(四期、五期環保車) (Dr.3/4")

- Use the torque wrench to control the nut to tighten or loosen bearing.
- Material: SCM440.
- Application: DAF TRUCK
- 材質: SCM440.
- 適用車種: DAF 卡車
- 使用扭力扳手來控制螺帽，以鎖緊或鬆開培林

Dr. 3/4"

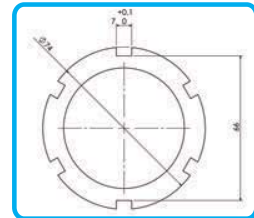

NUT SIZE

### H.C.B-A1465

### DAF PISTON RING INSTALLATION SLEEVE TOOL

DAF 汽缸套活塞安裝器

- Special design of cone tool make piston ring into cylinder sleeve easily ,save time and labor!
- Used to guide the piston into the cylinder sleeve during piston installation.
- 將此工具套在汽缸前端，此工具的錐型設計使安裝時可順利讓活塞滑進，節省時間與人力。
- 當安裝活塞時，此工具於引導所述活塞進入汽缸套。



### H.C.B-A1521

### DAF(LF) 12/17 TONS OIL FILTER WRENCH (EURO 4/5)(Dr. 1/2",10 FLUTES, 92 mm)

DAF(LF) 12/17 噸 (EURO 4/5期)機油芯扳手  
(Dr. 1/2", 10 角, 92 mm)

- Size: 92 mm × 10 FLUTES × 1/2" DRIVE
- Application: DAF(LF) 17 TONS OIL FILTER WRENCH (EURO 4/5)
- 尺寸:92 mm x 10角 x Dr. 1/2"
- 適用車種: DAF(LF)17 TONS (EURO 4/5期)
- 原廠料號: 1399494

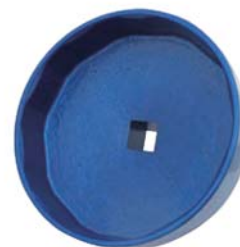





歐系卡車修護工具

European Truck Repair Tool



011

HWANG CHERNG BIN  
Specialty Tools Inc.



### H.C.B-A1190

### DAF STEERING LINKAGE FIXING BASE SOCKET (Dr. 1/2")

DAF 卡車方向機連桿固定座拆裝套筒 (Dr. 1/2")

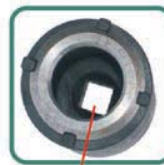

Dr. 1/2

#### NUT SIZE

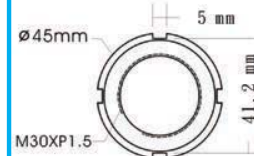

### H.C.B-A1244

### DAF TRUCK FLYWHEEL ROTATOR (35-42TONS) (EURO 3)

DAF 卡車曲軸飛輪轉動器 (35-42噸) (三期環保)

- The tool is designed for rotating crankshaft for timing.
- Application: DAF (35 TONS-42TONS) (euro 3) truck.
- 此工具用來轉動曲軸飛輪校正正時
- 適用車種 : DAF 35-42噸卡車



### H.C.B-A1398

### DAF TRUCK FLYWHEEL ROTATOR (35-42 TONS) (EURO 4)

DAF 卡車曲軸飛輪轉動器(35~42噸) (四期環保)

- The tool is designed for rotating crankshaft for timing.
- Application : DAF (35-42 TONS) (euro 4)  
and XF105 (euro 5) truck
- 此工具用來校正正時。
- 適用車種 : DAF 35~42噸(四期環保)  
及XF105 (五期環保)的卡車



### H.C.B-A1432

### DAF TRANSMISSION NEUTRAL POSITION ADJUSTMENT TOOL

DAF 變速箱空檔位置校正器

- Used to adjust the neutral position of transmission.
- H.C.B-A1432-1 is for adjusting the control-rods in the upper part of transmission.  
H.C.B-A1432-2 is for adjusting the selector shafts of transmission.
- Application: DAF Tiptronic truck (EURO 3.4.5)
- 此工具用來調整變速箱空檔位置。
- H.C.B-A1432-1 用來校正變速箱上蓋的推桿
- H.C.B-A1432-2 調整變速箱本體檔位
- 適用車種 : DAF (三、四、五期環保) 手自排卡車

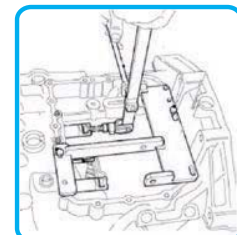



011

HWANG CHERNG BIN  
Specialty Tools Inc.

歐系卡車修護工具

European Truck Repair Tool



European Truck  
Repair Tool(DAF)

## H.C.B-A1271

DAF卡車變速箱拆裝吊具 (ZF 16速)

- Application: European truck --- DAF  
Japanese truck --- HINO
- 適用車種：歐系 --- DAF  
日系 --- HINO

## DAF TRUCK TRANSMISSION ASSEMBLY REMOVAL/INSTALLATION KIT (ZF 16S)



## H.C.B-A1271-A

### DAF TRUCK TRANSMISSION ASSEMBLY REMOVAL/INSTALLATION SLING(ZF 16S)

DAF卡車變速箱拆裝吊具 (ZF 16速)

- Assists to take transmission main shaft, counter shaft and gear shift lever apart all together.
- 可將變速箱主軸，副軸和齒輪軸桿一起吊出。

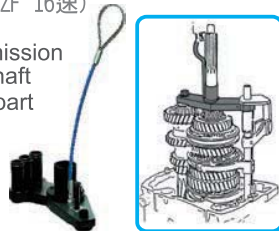

## H.C.B-A1271-E

### DAF TRUCK TRANSMISSION PLANETARY GEAR RETAINING BOLT (ZF 16S)

DAF卡車變速箱主軸撥叉螺栓 (ZF 16速)

- This tool helps to install and extract transmission main shaft smoothly.
- 用來協助順利拆裝變速箱主軸。



## H.C.B-A1271-B

### DAF TRUCK TRANSMISSION MAIN SHAFT AND COUNTER SHAFT FIXED SEAT (ZF 16S)

DAF卡車變速箱主副軸固定座 (ZF 16速)

- Put main shaft, counter shaft and gear shift lever on this fixation to prevent damage.
- 將變速箱主軸，副軸和齒輪軸桿放在本固定座上，以避免損壞。



## H.C.B-A1271-F

### DAF TRUCK TRANSMISSION MAIN SHAFT BEARING INSTALLER (ZF 16S)

DAF卡車變速箱主軸培林安裝器 (ZF 16速)



Ø102 x 96 x 274 mm (L)

## H.C.B-A1271-C

### DAF TRUCK PLANETARY GEAR GROUP SUPPORTING PLATE (ZF 16S)

DAF卡車變速箱缸體支撐板 (ZF 16速)

- Before assembling the planetary gear train, use this tool to test if the block leakage or not while the piston acting.
- 在組裝行星齒輪前，用本工具測試活塞動作時，有沒有漏氣的狀況。



## H.C.B-A1271-G

### DAF TRUCK TRANSMISSION MAIN SHAFT BEARING INSTALLER (ZF 16S)

DAF卡車變速箱主軸培林安裝器 (ZF 16速)



Ø96 x 90 x 204 mm (L)

## H.C.B-A1271-D

### DAF TRUCK TRANSMISSION PLANETARY GEAR ASSEMBLY SLING (ZF 16S)

DAF卡車變速箱行星齒輪總成吊具 (ZF 16速)

- This tool is designed for helping lift the transmission planetary gear.
- 用本工具來協助抬起行星齒輪。



## H.C.B-A1271-H

### DAF TRUCK TRANSMISSION MAIN SHAFT BEARING INSTALLER (ZF 16S)

DAF卡車變速箱主軸培林安裝器 (ZF 16速)

- H.C.B-A1271-F&G&H: assists to push the bearing into main shaft.
- H.C.B-A1271-F&G&H可將培林壓入主軸內。



Ø 93 x 77 x 194 mm (L)





歐系卡車修護工具

European Truck Repair Tool



011

HWANG CHERNG BIN  
Specialty Tools Inc.



### H.C.B-B1271

### TRUCK TRANSMISSION / BEARING / SHAFT SLEEVE / GEAR PULLER SET (ZF16S)

卡車變速箱/培林/軸套/齒輪拆卸工具組 (ZF 16速)

- Features:  
The best tool for removing ZF16S transmission, bearing, shaftsleeve and gear and won't damage the bearing, shaft sleeve, gear and related parts.  
Easy to use. Save time and money!

- Technical information:  
Choose appropriate accessory before operation.  
Put accessory puller into right place of bearing, shaft sleeve or gear, then slip fix ring on main body, and then fix screw on double ends, finally take out spare part by rotating central bolt.

- Application: European truck-DAF Japanese truck-HINO  
ZF 16S151-16S181

- 特性:  
移除ZF16速變速箱、培林、軸套、齒輪的最佳工具，不會損壞培林、軸套、齒輪及相關零件。  
方便使用！省時及省錢。

- 使用方法:  
操作前請選擇合適的配件。

- 拆卸時將拆卸塊放置於培林、軸套或齒輪的正確位置，再將本體套上固定環，兩端螺絲旋緊，之後轉動中心螺桿就可取出
- 適用車種：歐系-DAF 日系-HINO ZF 16S151-16S181



Bearing stock number : FAG 575194



Bearing stock number : SKF 4395/2/QCL7C VQ492

### H.C.B-C1271

NEW

### TRUCK TRANSMISSION / BEARING / SHAFT SLEEVE / GEAR PULLER KIT (ZF16S221-16S251)

卡車變速箱/培林/軸套/齒輪拆卸工具組 (ZF16S221-16S251)

- Feature:
  - This tool is used to divide the transmission main shaft, bearing sleeve and gear of ZF 16 speed.
  - When the bearing or gear is damaged, you can use this tool to divide them from the shaft. It can help you work efficiency and save time.

- 說明:
  - 此工具是用來分解ZF16速變速箱主軸、培林軸套、齒輪
  - 當變速箱主軸上，有培林、齒輪損壞時，就可用此套工具來拆卸，省時，有效率



VIDEO



European Truck Repair Tool(DAF)







### H.C.B.-B1602

**NEW**

### DAF TRUCK DIFFERENTIAL V TORSION BAR BUSH REMOVAL / INSTALLATION TOOL KIT (75 mm)

DAF 卡車差速器V型扭力桿鐵套拆裝工具組(75 mm)

- Feature:  
This tool kit allows the removal and installation of the center/end bushings of DAF truck differential V type torsion rod.  
※Require hydraulic system when removing/installing.
- 說明: 此工具用於拆卸及安裝DAF卡車差速器V型扭力桿中心及兩端75mm鐵套  
※須使用油壓工具進行拆裝



### H.C.B.-A1636

**NEW**

### DAF(CF)CRANKSHAFT FRONT OIL SEAL INSTALLER (35-42 TONS) (EURO 4/5)

DAF(CF)曲軸前油封安裝器(35-42噸)(4/5期環保)

- Feature: With this tool, you can install the oil seal without damaging the oil seal or parts.
- Oil seal OEM no. ref.: 1684105
- Application: DAF(CF) 35-42 tons (Euro 4/5) truck.
- 說明: 此工具讓你在安裝油封過程不會損壞到油封及零件。
- 油封料號: 1684105
- 適用車種: DAF(CF) 35-42噸 (4/5期環保)卡車



Part no:1684105





011

HWANG CHERNG BIN  
Specialty Tools Inc.

歐系卡車修護工具

European Truck Repair Tool



European Truck  
Repair Tool (BENZ)

### H.C.B-A1242

### BENZ ACTROS PITMAN ARM PULLER (Dr. 3/4", 42 mm)

BENZ ACTROS卡車方向機搖臂拆卸器 (Dr. 3/4", 42 mm)

6 / 27 / 28 / 1.32'

- Save time and labor.
- No need to destroy the pitman arm.
- Application: Benz Actros & MAN 414
- 省時省力。
- 不需破壞方向機搖臂。
- 適用車種：Benz卡車Actros & MAN 球接頭



### H.C.B-A1263

### TRUCK POSITION SENSOR SOCKET (Dr. 1/2", 8 POINTS, 27 mm)

卡車位置感應器套筒 (Dr. 1/2", 8角, 27 mm)

- For removing / replacing truck position sensor.
- Material: SCM440, HRC: 30°~35°
- Length: 60 mm
- The tool is not allowed to work with air wrench.
- Application: Mercedes-Benz commercial vehicles SK series, Actros, MAN commercial vehicles, SCANIA, ZF 16 speeds gear box.

- 可用來移除/更換卡車位置感應器
- 材質：SCM440，硬度：30°-35°
- 長度：60 mm
- 本工具不可與氣動扳手一起使用。
- 適用車種：Mercedes-Benz卡車SK系列，Actros，MAN商務車，SCANIA，ZF 16速卡車。

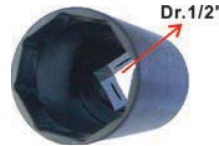

### H.C.B-A1314

### BENZ & MAN TRUCK FRONT AXLE NUT SOCKET (Dr. 3/4", SW 60 mm, 76 mm)

BENZ & MAN 卡車前輪軸螺帽套筒  
(Dr. 3/4", SW 60 mm, 76 mm)

- Specifications : Dr. 3/4" x SW 60 mm x 76 mm
- Application:  
MAN and BENZ 9 tons strengthen front axle VL5.  
Benz SK front axle VL5/1 D-9, VL5/2 D-9, series 2629/6x4, 2635 K/6x4, 3535 K8/x4/4, such as Benz Actros with disc brake and FAUST 9 tons front axle.

- 規格：Dr. 3/4" x SW 60 mm x 76 mm
- 適用車種：  
MAN和Benz 9噸卡車的強化前軸VL5  
Benz SK前軸VL5/1 D-9, VL5/2 D-9, 2629/6x4, 2635 K/6x4, 3535 K8/x4/4系列。  
如：配備碟刹的Benz Actros及FAUST 9噸的前軸。



### H.C.B-B1314

### BENZ & MAN TRUCK FRONT AXLE NUT SOCKET (Dr. 3/4", SW 56 mm, 71 mm)

BENZ & MAN卡車前輪軸螺帽套筒  
(Dr. 3/4", SW 56 mm, 71 mm)

- Specification: Dr. 3/4" x SW 56 mm x 71 mm
- Application:  
DAF, BENZ trucks (axles VL 3/8, 13, VO 3/10, VL 4/7, 9, 10, VD 4/14, VO 4/11, 13, 18, VL4/15, 16, 19 and VD 4/20 in type 363, 385, 387, 389, 391, 393, 395, 617, 620, 621, 622, 623, 625 and 649 (ex: BENZ ACTROS with drum brake tightening nut no. 652 330 00 88) BENZ buses (axles VO 3/10, 4/11, 4/13 and 4/19 in type 0303, 0305-G and 0307) MAN trucks (with clamping nut no. 81.92901-0066) KASSBOHRER / SETRA (front axle 6,5 + 7,5 in types S210 and 215, SG 219-221 and non-driven rear axle types S216 HDS and S228 DT)

- 規格：Dr. 3/4" x SW 56 mm x 71 mm
- 適用車種：  
DAF, BENZ卡車(系列363, 385, 387, 389, 391, 393, 395, 617, 620, 621, 622, 623, 625和649的車軸VL 3/8, 13, VO 3/10, VL 4/7, 9, 10, VD 4/14, VO 4/11, 13, 18, VL4/15, 16, 19 and VD 4/20 (如：BENZ的ACTROS鼓刹鎖定螺帽編號652 330 00 88) BENZ遊覽車(系列0303, 0305-G和0307的車軸VO 3/10, 4/11, 4/13和4/19) MAN卡車(鎖定螺帽編號81.92901-0066) KASSBOHRER / SETRA系列(S210和S215, SG 219-221的前軸6,5和7,5。S 216 HDS和S 228 DT的非帶動後軸)







### H.C.B-A1441

### BENZ TRUCK (2640) DRIVE AXLE NUT REMOVAL/INSTALLATION SOCKET (Dr. 3/4", 6 TEETH)

BENZ 卡車(2640)帶動軸螺帽拆裝套筒 (Dr. 3/4", 6齒)

- The unique design and profile of the socket make it perfectly flush in position and prevent the damage of axle nut.
- Fix bearing while removing or installing the truck nut.
- Use the torque wrench to control the nut to tighten or loosen bearing.
- Material: SCM440.
- Application: BENZ TRUCK (2640) DRIVE AXLE.

- 特殊的設計使套筒能精準卡住輪軸螺帽，避免輪軸螺帽的損壞。
- 移除或安裝卡車帶動軸螺帽時，需使用本工具來固定培林。
- 使用扭力扳手來控制螺帽，以鎖緊或鬆開培林。
- 材質：SCM440
- 適用車種：賓士卡車(2640)帶動軸

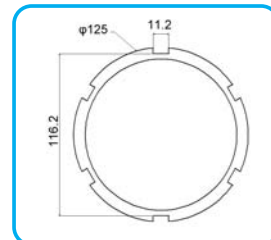

NUT SIZE



### H.C.B-A1442

### BENZ TRUCK (2640) LIFT AXLE NUT REMOVAL / INSTALLATION SOCKET (Dr. 3/4", 6 TEETH)

BENZ 卡車(2640)舉升軸螺帽拆裝套筒 (Dr. 3/4", 6齒)

- The unique design and profile of the socket make it perfectly flush in position and prevent the damage of axle nut.
- Fix bearing while removing or installing the truck nut.
- Use the torque wrench to control the nut to tighten or loosen bearing.
- Material: SCM440.
- Application: BENZ TRUCK (2640) LIFT AXLE.

- 特殊的設計使套筒能精準卡住輪軸螺帽，避免輪軸螺帽的損壞。
- 移除或安裝卡車舉升軸螺帽時，需使用本工具來固定培林。
- 使用扭力扳手來控制螺帽，以鎖緊或鬆開培林。
- 材質：SCM440
- 適用車種：賓士卡車(2640)舉升軸

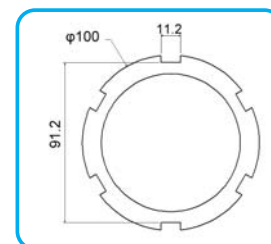

NUT SIZE



### H.C.B-A1443

### BENZ TRUCK WHEEL AXLE NUT SOCKET ( Dr.1" )

BENZ 卡車輪軸螺帽套筒 (Dr. 1")

- Used to removing or installing the truck wheel axle nut
- Application: BENZ truck
- 用來拆裝卡車輪軸螺帽
- 適用車種：BEZN truck

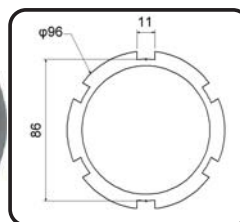

NUT SIZE





011

HWANG CHERNG BIN  
Specialty Tools Inc.

歐系卡車修護工具

European Truck Repair Tool



European Truck  
Repair Tool

### H.C.B-A1384

### BENZ TRUCK TRANSMISSION OIL LEVEL GAUGE

BENZ 卡車變速箱機油尺

- For measuring the oil level of transmission.
- Application: BENZ truck
- 可用來測量變速箱的油量
- 適用車種 : BENZ卡車



### H.C.B-A1387

### BENZ AXLE NUT SOCKET (H36, 12 POINTS, 95 mm)

BENZ 輪軸螺帽套筒 (H36, 12角, 95 mm)

6 / 19.4 / 20 / 1.41'

- The size of drive nut is 6 points, 36 mm.
- Suited to male nut in the axle.
- It can be used with impact wrench or torque wrench.
- Size: H36, 12 points, 95 mm
- Application: BENZ Trailer
- 套筒上帶動螺帽的尺寸為外六角, 36 mm。
- 可拆卸輪軸上的螺帽。
- 可搭配衝擊扳手或扭力扳手一起使用。
- 尺寸: H36, 12角, 95 mm
- 適用車種: Benz拖車



### H.C.B-B1387

### IVECO AXLE NUT SOCKET (H36, 12 POINTS, 110 mm)

IVECO 輪軸螺帽套筒 (H36, 12角, 110 mm)

6 / 18 / 18.5 / 1.41'

- The size of drive nut is 6 points, 36 mm.
- Suited to male nut in the axle.
- It can be used with impact wrench or torque wrench.
- Size: H36, 12 points, 110 mm
- Application: IVECO Eurotech-Cursor
- 套筒上帶動螺帽的尺寸為外六角, 36 mm。
- 可拆卸輪軸上的螺帽。
- 可搭配衝擊扳手或扭力扳手一起使用。
- 尺寸: H36, 12角, 110 mm
- 適用車種: IVECO Eurotech-Cursor



SWmm	Hex	Ø mm	H
110	36	133	116

### H.C.B-C1387

### IVECO AXLE NUT SOCKET (H36, 12 POINTS, 105 mm)

IVECO輪軸螺帽套筒(H36, 12角, 105 mm)

- The size of drive nut is 6 points, 36 mm.
- Suited to male nut in the axle.
- It can be used with impact wrench or torque wrench.
- Size: H36, 12 points, 105 mm
- Application: IVECO Eurotech-Cursor lorries
- 可搭配氣動扳手與扭力扳手使用
- 尺寸: H36, 12角, 105 mm
- 適用車種: IVECO Eurotech-Cursor lorries





### H.C.B-A1561

### IVECO WHEEL NUT SOCKET (Dr. 1", 85 mm, 12 POINT)

IVECO 輪軸螺帽套筒(Dr. 1", 85 mm, 12角)

- Polygonal wrench for hubs- IVECO.
- Axle nut disassembly
- Suitable for IVECO models
- Polygon 85 mm
- Inner Ø 83 mm - Square 1"
- 適用車種: IVECO
- 尺寸: 12角, 85 mm, Dr. 1, 內徑 Ø 83 mm



Dr. 1"

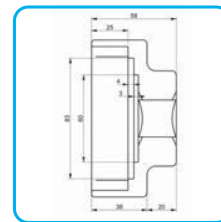
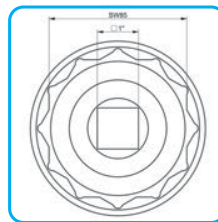

### H.C.B-A1411-95

### BENZ AXLE NUT SOCKET (H36, 6 POINTS, 95 mm)

BENZ 輪軸螺帽套筒 (H36, 6角, 95 mm)

6 / 18 / 19 / 1.27'

- The unique design and profile of the socket make it perfectly flush in position and prevent the damage of axle nut
- The robust socket is manufactured from a piece of material.
- It can be used with impact wrench or torque wrench for installing and removing.
- Material : SCM440.
- Size: H36, 6 POINTS, 95 mm, L : 157 mm
- Application : Mercedes Benz axle trailers.

- 特殊的設計使套筒能精準卡住輪軸螺帽，避免輪軸螺帽損壞。
- 此套筒採一體成型的設計。
- 可搭配衝擊扳手或扭力扳手一起使用
- 材質：SCM440.
- 尺寸：H36，6角，95 mm，長度：157 mm
- 適用車種：Mercedes Benz axle trailers.



### H.C.B-A1411-98

### IVECO AXLE NUT SOCKET(H36, 6 POINTS, 98 mm, Dr. 3/4")

IVECO 輪軸螺帽套筒 (H36, 6角, 98 mm, Dr. 3/4")

6 / 18 / 19 / 1.27'

- The unique design and profile of the socket make it perfectly flush in position and prevent the damage of axle nut
- The robust socket is manufactured from a piece of material.
- It can be used with impact wrench or torque wrench for installing and removing.
- Material: SCM440.
- Size: H36 · 6 POINTS · 98 mm · L: 115 mm · Dr. 3/4"
- Application: IVECO Euro Cargo etc...  
ISUZU 15 Tons Truck (263) rear wheel axle nut.

- 特殊的設計使套筒能精準卡住輪軸螺帽，避免輪軸螺帽損壞。
- 此套筒採一體成型的設計。
- 可搭配衝擊扳手或扭力扳手一起使用
- 材質：SCM440.
- 尺寸：H36，6角，98 mm，長度：115 mm，Dr. 3/4"。
- 適用車種：IVECO Euro Cargo etc...  
ISUZU 15噸卡車(263)後輪輪軸螺帽



Dr. 3/4"



ISUZU 15 TONS TRUCK (263)





011

HWANG CHERNG BIN  
Specialty Tools Inc.

歐系卡車修護工具

European Truck Repair Tool



European Truck  
Repair Tool

### H.C.B-A1601

NEW

### IVECO 3.5/7 TONS OIL FILTER WRENCH (Dr. 1/2", 10 FLUTES, 94.5 mm)

IVECO 3.5/7 噸 機油芯扳手(Dr. 1/2", 10 角, 94.5 mm)

- Size: 94.5 mm x 10 FLUTES x 1/2" DRIVE
- Application: IVECO 3.5 tons and 7 tons
- 尺寸: 94.5 mm x 10 FLUTES x 1/2" DRIVE
- 適用車種: IVECO 3.5噸和7 噸



### H.C.B-A1603

NEW

### IVECO 3.5/ 7 TONS TIRE NUT CROSS WRENCH (27 mm)

IVECO 3.5/7噸輪胎螺絲十字扳手(27 mm)

- Feature: This tool is used to remove/ install the rear/ front tire nuts of IVECO 3.5 tons and 7 tons truck.
- Application: IVECO 3.5 tons and 7 tons truck
- 說明: 此工具可拆/裝IVECO 3.5噸和7噸前、後輪胎螺絲
- 適用車種: IVECO 3.5噸和7噸卡車



### H.C.B-A1618

NEW

### IVECO DUAL GEAR ENGINE FLYWHEEL ROTATOR (WITH 2 GEARS)

IVECO DUAL 齒輪引擎飛輪轉動器(2 齒)

- Designed for dual gear engine flywheel rotation for timing .
- Suitable for IVECO models
- Engine models: 8360.46 / F3A / F3B
- Application: Euro Cargo / Cargo 150E27R PR / FPR 320E27T / PT Eurotech / Eurostar models
- 適用車種: Euro Cargo / Cargo 150E27R PR / FPR 320E27T / PT Eurotech / Eurostar models
- 引擎代號: 8360.46 / F3A / F3B
- 此工具設計用於轉動引擎飛輪以利正時。
- 適用IVECO



### H.C.B-A1634

NEW

### RENAULT MAGNUM TRUCK ENGINE FLYWHEEL ROTATOR (Dr. 1/2")

RENAULT MAGNUM 卡車引擎飛輪轉動器(Dr. 1/2")

- Tool for engine flywheel rotation during the tappets adjustment
- Application: RENAULT MAGNUM
- 此工具用來校正曲軸正時
- 適用車種: RENAULT MAGNUM





### H.C.B-A1280

### YORK REAR WHEEL NUT SOCKET (8 POINTS, 95 mm)

YORK 後輪螺帽拆裝套筒 (8角, 95 mm)

- Fix bearing while removing or installing the truck nut.
- Use the air wrench or rod to control the nut to tighten or loose bearing
- 在拆卸或安裝卡車螺帽時，用來固定培林。
- 以氣動扳手或扳桿調整螺帽，以控制培林的鬆緊度。



### H.C.B-A1422

### BENZ TRUCK FILTER WRENCH (46 mm)

BENZ 卡車機油芯套筒(46 mm)

- To remove the oil filter of BENZ truck.
- The robust socket is manufactured from a piece of material.
- It can be used with torque wrench for installing and removing.
- Size: 6 POINTS, 46 mm, Dr. 3/8"
- Material : SCM440
- Application: BENZ TRUCK ACTROS, ATEGO, AXOR AND ECONIC....

- 用來拆裝BENZ卡車機油芯
- 套筒採一體成型的設計
- 可搭配扭力扳手一起使用
- 尺寸：6角, 46 mm, Dr. 3/8"
- 材質：SCM440
- 適用車種：BENZ 卡車 ACTROS, ATEGO, AXOR AND ECONIC....



### H.C.B-A1282

### YORK ROTATING AXLE SHAFT TIE ROD BUSH REMOVE / INSTALLATION TOOL KIT

YORK 自轉軸橫拉桿鐵套拆裝工具組

- Safe removal/ replacement of YORK rotating axle shaft tie rod bush.
- The kit can be easily operated with H.C.B-B3036 (Air Pump).
- 使用本工具組安全拆卸/更換YORK自轉軸鐵套。
- 可搭配B3036一起使用。



Bush



Installation



Extraction

### H.C.B-A1283

### FUWA WHEEL SHAFT COVER SOCKET (Dr. 1", 8 POINTS, 123 mm)

福華板車輪軸蓋拆裝套筒 (Dr. 1", 8角, 123 mm)

- The socket for extracting / installing wheel shaft cover.
- Application: FUWA
- 可拆卸及安裝板車輪軸蓋。
- 適用車種：FUWA





011

HWANG CHERNG BIN  
Specialty Tools Inc.

歐系卡車修護工具

European Truck Repair Tool



European Truck  
Repair Tool

### H.C.B-A2178

### TRUCK INJECTION NOZZLE SOCKET

卡車噴油嘴拆裝套筒

- This tool is for removing and installing diesel injection nozzle.
- Loosen nut of injection nozzle by A2178-1, tighten the center bolt by using A2178-2 and then remove nozzle.
- Application: Man(422.403), Benz Truck, Scania
- 可拆卸及安裝柴油噴油嘴
- 使用 A2178-1 轉開噴油嘴螺帽，再以 A2178-2 鎖緊噴油嘴中心螺絲，拉出噴油嘴。
- 適用：Man (422.403), Benz Truck, Scania



### H.C.B-A2212

### TRUCK INJECTOR SOCKET KIT (4 PCS)

卡車噴油嘴套筒組 (4 PCS)

- For removing and installing the injector of truck.
- 使用本工具組移除及安裝卡車的噴油嘴。
- Specification:



	A2212-1	A2212-2	A2212-3 (A2178)	A2212-4 (A1071)
	H32	Dr. 1/2"	H32 & H24	Dr. 1/2"
Inner Ø (mm) 內徑	22.5	23	22	22.2
Outer Ø (mm) 外徑	28.5	30	28.5	28.5
Long (mm) 長度	122	122	84.5	72
Weight (g) 重量	260	168	164	280
Teeth 齒數	4	3	4	4
Material 材質	S45C	SCM 440	S45C	SCM 440
Applicable 適用車種	Benz Euro 2 engine, MAN Benz 二期環保引擎, MAN	Benz, Man	Benz, MAN (403, 422) and Scania	Benz, MAN (403, 422) and Scania
Description 說明	<ul style="list-style-type: none"> <li>● Open and permeable type</li> <li>● To extract the cable from the needle motion sensors</li> <li>● 開口、可穿過式</li> <li>● 可移除針狀物做感應器的電線</li> </ul>		<ul style="list-style-type: none"> <li>● For diesel engine.</li> <li>● Thread size of H24: M14 x P1.5</li> <li>● 適用於柴油引擎</li> <li>● H24 尺寸: M14 x P1.5</li> </ul>	<ul style="list-style-type: none"> <li>● For diesel engine.</li> <li>● 適用於柴油引擎</li> </ul>





歐系卡車修護工具

European Truck Repair Tool



011

HWANG CHERNG BIN  
Specialty Tools Inc.



### H.C.B-A2222

### DIESEL INJECTOR SOCKET KIT (4 PCS)

柴油噴油嘴套筒組 (4 PCS)

10 / 11.4 / 12.4 / 0.8'

Item No. 編號	Description 規格	Diameter 直徑	Length 長度
A2222-1	12 points socket 12 角套筒	28mm	78mm
A2222-2	12 points socket 12 角套筒	27mm	78mm
A2222-3	12 points socket 12 角套筒	22mm	80 mm
A2222-4	6 points socket 6 角套筒	22 mm	110mm

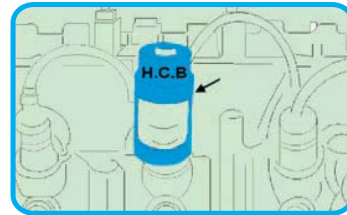

- Four Chrome Vanadium open-sided Dr. 1/2 sockets for diesel injector removal and installation.
- Application: Alfa Romeo, Chrysler, BMW, Ford, VW, Mercedes-Benz, AUDI, OPEL, Vauxhall, Seat, VOLVO, ROVER, MAN 2.5TD, SCANIA HGVS and Peugeot
- 四支Dr. 1/2" 鉻鈦鋼材質開口套筒，可用來移除和安裝柴油噴油嘴。
- 適用車種：Alfa Romeo, Chrysler, BMW, Ford, VW, Mercedes-Benz, AUDI, OPEL, Vauxhall, Seat, VOLVO, ROVER, MAN 2.5TD, SCANIA HGVS 和 Peugeot

### H.C.B-A1390

### EUROPEAN TRUCK DISC BRAKE CALIPER SOCKET (Dr. 3/8", 11 TEETH)

歐系卡車碟煞卡鉗套筒 (Dr. 3/8", 11齒)

- For removing / installing disc brake caliper of European trucks.
- Size: Dr. 3/8", 11 teeth, 26 mm/L
- Application: European trucks, such as VOLVO.RENAULT.SCANIA.DAF
- 用來拆裝歐系卡車的碟煞卡鉗。
- 尺寸：Dr. 3/8"，11齒，26mm/長
- 適用車種：歐系卡車。
- 如：VOLVO.RENAULT.SCANIA.DAF





011

HWANG CHERNG BIN  
Specialty Tools Inc.

歐系卡車修護工具

European Truck Repair Tool



European Truck  
Repair Tool

### H.C.B-A1403

### BPW (12 TONS) TRAILER OIL SEAL INSTALLER

BPW 12 噸板車輪軸油封安裝器

- To prevent the oil seal from damage when installing. It is very easy to damage oil seal without using this tool.
- Due to the special smooth surface design, the force on oil seal can be average when installing.
- Application: BPW 12 TONS TRAILER
- Oil Seal Genuine no.: MOAY 134.94 159.55 12.7
- 正確使用此工具可避免安裝時損壞油封。
- 如果未使用此工具，在更換時容易損壞到油封。
- 此工具特殊平滑的設計，使在安裝油封時能平均受力。
- 適用車種: BPW 12噸板車
- 油封料號: MOAY 134.94 159.55 12.7

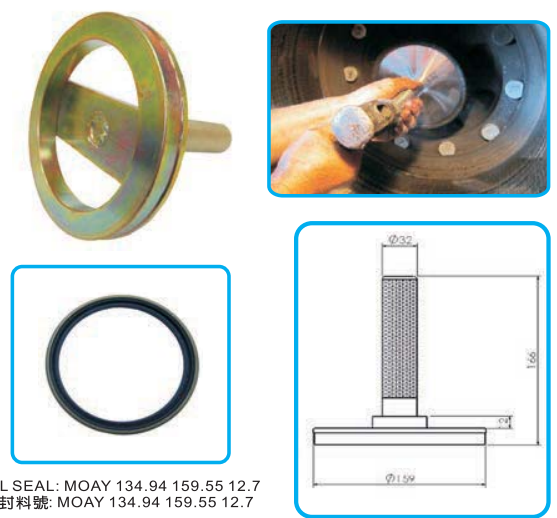

OIL SEAL: MOAY 134.94 159.55 12.7  
油封料號: MOAY 134.94 159.55 12.7

### H.C.B-A1434

### LIEBHERR CRANE WHEEL SOCKET (Dr. 1")

LIEBHERR 吊車輪軸蓋套筒 (Dr. 1")

- For removing and installing the wheel cover
- Material : SCM 440
- Application : LIEBHERR CRANE
- 用來拆裝輪軸蓋的套筒
- 材質 : SCM 440
- 適用車種 : LIEBHERR 吊車

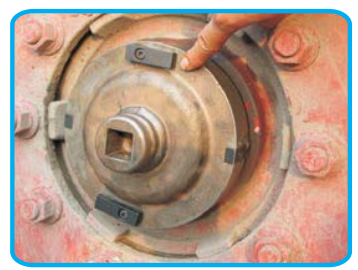

### H.C.B-A1404

### ROR TRAILER REAR WHEEL NUT SOCKET (Dr. 1" ,8 POINT, 83 mm, 3 1/4") (DRUM BRAKE)

ROR 板車輪軸螺帽套筒 (鼓式剎車)  
(Dr. 1" 8角, 83 mm, 3 1/4")

- Remove the rear wheel nut of ROR trailer to change the bearing.
- The robust socket is manufactured from a piece of material.
- It can be used with torque wrench for installing and removing.
- Material: SCM440.
- Size: Dr. 1" , 8 POINTS, 3 1/4", 83 mm
- Application: ROR TM series Trailer wheel nut.
- 用來拆裝ROR 板車輪軸螺帽，來更換培林
- 此套筒採一體成型的設計
- 可搭配扭力扳手一起使用
- 材質: SCM440.
- 尺寸: Dr. 1" ,8角, 3 1/4", 83 mm
- 適用車種: ROR TM 系列板車輪軸

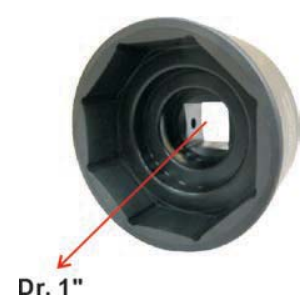



歐系卡車修護工具

European Truck Repair Tool



011

HWANG CHERNG BIN  
Specialty Tools Inc.



# H.C.B-B1488-120

**NEW**

## ROR REAR WHEEL HUB NUT SOCKET (DISC BRAKE) (Dr. 1" , 8 POINT, 120 mm)

ROR 板車輪軸螺帽套筒 (碟式煞車) (Dr. 1" , 8 角, 120 mm)

- For removing the rear wheel nut of ROR trailer to change the bearing.
- Size: Dr. 1", 8 POINTS, 120 mm
- Application: ROR TM series Trailer rear wheel nut.
- 用來拆裝ROR 板車輪軸螺帽，來更換培林
- 尺寸: Dr. 1" , 8 角, 120 mm
- 適用車種: ROR TM 系列板車輪軸

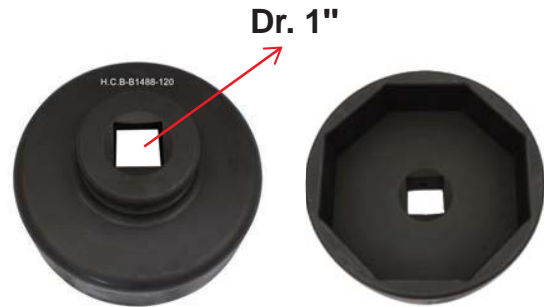

Item	Dr.	SW	Item	Dr.	SW	Application
A1488-70	3/4"	70mm	B1488-70	1"	70mm	
A1488-75	3/4"	75mm	B1488-75	1"	75mm	
A1488-80 (B1125)	3/4"	80mm	B1488-80 (C1125)	1"	80mm	SCANIA FRONT WHEEL
A1488-85	3/4"	85mm	B1488-85	1"	85mm	TOYOTA TRUCK UNDER 8.5 TONS(REAR WHEEL)
A1488-90	3/4"	90mm	B1488-90	1"	90mm	
A1488-95	3/4"	95mm	B1488-95	1"	95mm	HINO 10.4-11TON
A1488-100 (B1126)	3/4"	100mm	B1488-100 (C1126)	1"	100mm	SCANIA REAR WHEEL
A1488-105	3/4"	105mm	B1488-105	1"	105mm	
A1488-110	3/4"	110mm	B1488-110	1"	110mm	
A1488-115	3/4"	115mm	B1488-115	1"	115mm	HINO,FUSO REAR WHEEL HINO 17,21,25,35,42 TON
A1488-120	3/4"	120mm	B1488-120	1"	120mm	
A1488-125	3/4"	125mm	B1488-125	1"	125mm	
A1488-130	3/4"	130mm	B1488-130	1"	130mm	
A1488-135	3/4"	135mm	B1488-135	1"	135mm	
A1488-140	3/4"	140mm	B1488-140	1"	140mm	
A1488-145	3/4"	145mm	B1488-145	1"	145mm	
A1488-150	3/4"	150mm	B1488-150	1"	150mm	
A1488-155	3/4"	155mm	B1488-155	1"	155mm	
A1488-160	3/4"	160mm	B1488-160	1"	160mm	
A1488-165	3/4"	165mm	B1488-165	1"	165mm	
A1488-170	3/4"	170mm	B1488-170	1"	170mm	
A1488-175	3/4"	175mm	B1488-175	1"	175mm	
A1488-180	3/4"	180mm	B1488-180	1"	180mm	
A1488-185	3/4"	185mm	B1488-185	1"	185mm	
A1488-190	3/4"	190mm	B1488-190	1"	190mm	
A1488-195	3/4"	195mm	B1488-195	1"	195mm	
A1488-200	3/4"	200mm	B1488-200	1"	200mm	

European Truck Repair Tool





011

HWANG CHERNG BIN  
Specialty Tools Inc.

歐系卡車修護工具

European Truck Repair Tool



European Truck  
Repair Tool

### H.C.B-A1482

### BENZ REAR AXLE NUT SOCKET ( Dr. 3/4" , 105-125 mm)

BENZ 後輪軸螺帽套筒(Dr. 3/4", 105-125 mm)

- Fix bearing while removing and installing rear axle nut.
- It can be used with torque wrench for installing and removing.
- Material: SCM440.
- Application: Mercedes Benz Actros Rear axle HL/HL 8 (Hypoid).
- 當拆裝後輪軸螺帽時用來固定培林
- 拆和裝時候，可使用扭力扳手
- 材質: SCM440.
- 適用車種：Mercedes Benz Actros Rear axle HL/HL 8 (Hypoid).



ITEM	Inner Ømm	Outer Ømm	H mm	Stud Ømm	Stud width mm
A1482	105	125	180	116	10

### H.C.B-A1483

### BENZ&MAN REAR AXLE NUT SOCKET ( Dr. 3/4" , 80-95 mm)

BENZ&MAN 後輪軸螺帽套筒 ( Dr. 3/4" , 80-95 mm)

- Rigid locating tube.
- Optional with expander sleeve(bayonet locking).
- It can be used with torque wrench for installing and removing.
- Application: Mercedes Benz Atego Rear axle, Vitaro 814, MAN, etc
- 堅固定位管
- 可選擇的擴展套(缺口鎖定)
- 可以搭配扭力扳手使用
- 適用車種: Mercedes Benz Atego Rear axle, Vitaro 814, MAN, etc



ITEM	Inner Ømm	Outer Ømm	Locating tube Ømm	H mm	Stud Ømm	Stud width mm
A1483	80	95	49	175	87	10

### H.C.B-A1448

**NEW**

### SAF BUSH REMOVAL/ INSTALLATION TOOL KIT

SAF 鐵套拆裝工具組

- Use this tool can remove and install the bush with less labor and time.
- **DO NOT use an impact wrench to turn the pivot bushing replacement tool.**
- 使用此工具能輕鬆拆裝SAF鐵套，節省許多人力與時間
- 注意: 請勿使用氣動工具



### H.C.B-A1466

### SAF WHEEL SHAFT COVER SOCKET ( Dr. 1" , 8 POINTS, 130 mm)

SAF 輪軸蓋拆裝套筒 (Dr. 1" , 8角, 130 mm)

- For extracting the wheel cover.
- Application: SAF
- 用來拆除輪軸蓋
- 適用車種：SAF





歐系卡車修護工具

European Truck Repair Tool



011

HWANG CHERNG BIN  
Specialty Tools Inc.



## H.C.B-A1492

### BENZ & MAN FLYWHEEL ROTATING TOOL (WITH 2 GEARS) (Dr. 1/2")

BENZ & MAN 卡車飛輪轉動工具(2齒)(Dr.1/2")

- Flywheel rotating tool with 2 gear wheels. H: 90 MM Dr. 1/2"
- This tool is used to allow precise positioning of the crankshaft for timing purposes.
- It can be operated with socket wrenches, open or ring wrenches.
- Application range:  
Mercedes Benz 6-/8-and 10-cylinder engines.  
Used on Mercedes trucks models 400 e.g. engines OM 401, 402, 403, 407, ACTROS, as well as for all MAN 12-cylinder engines.
- 尺寸: 飛輪轉動正時工具(2齒輪) H : 90 mm , Dr. 1/2"
- 此工具用來校正曲軸正時。
- 可搭配套筒、扳手使用。
- 適用範圍:  
賓士6-/8- 及10 汽缸引擎  
使用於賓士卡車400 例如 引擎OM 401,402,403,407,ACTROS 及 MAN 12 汽缸引擎



## H.C.B-A1493

### BENZ & MAN FLYWHEEL ROTATING TOOL (WITH 3 GEARS) (Dr. 1/2")

BENZ & MAN 卡車飛輪轉動工具(3齒)(Dr.1/2")

- Flywheel rotating tool with 3 gear wheels. Size: H : 120 mm, Dr. 1/2"
- This tool is used to allow precise positioning of the crankshaft for timing purposes.
- It can be operated with socket wrenches, open or ring wrenches.
- Application :  
Used on Mercedes trucks models 900 e.g. engines 904 and 906 ACTROS and ATEGO, as well as for all MAN engines. MAN number 80-99626-6006 (Not for 12-cylinder engines.)MAN 5-/6- and 8-cylinder engines - D25/28..., etc.
- 飛輪轉動正時工具(3齒輪),尺寸:H:120 mm , Dr. 1/2"
- 此工具用來校正曲軸正時。
- 可搭配套筒、扳手使用。
- 適用車種:  
賓士卡車型號900 · 例如: 引擎904及906 ACTROS 和 A TEGO ·  
也適用於所有MAN引擎。MAN編號80-99626-6006(不適用12汽缸引擎。)  
MAN 5-/6-和8汽缸引擎-D25-D28...等。



## H.C.B-A1494

### MAN FLYWHEEL ROTATING TOOL (WITH 1 GEAR) (Dr. 1/2")

MAN 飛輪轉動器(1齒)(Dr.1/2")

- Flywheel rotating tool with 1 gear wheels.
- With this tool you can rotate the engine precise when doing valve timing or other operations
- Application range: MAN engines D20.../D25.../D26.../D28...  
Flywheel rotating tool with 1 gear wheels.
- 飛輪轉動器 (1齒)(Dr. 1/2")
- 此工具用來校正曲軸正時
- 適用範圍: MAN 引擎 D20.../D25.../D26.../D28...





011

HWANG CHERNG BIN  
Specialty Tools Inc.

歐系卡車修護工具

European Truck Repair Tool



European Truck  
Repair Tool

### H.C.B-A1557-50

### BENZ ACTROS AXLE BOLT SOCKET(32 EPL, L: 50 mm)

BENZ ACTROS 輪軸螺絲套筒(32 EPL, L: 50 mm)

- For removing the mounting bolts of the axle on the Mercedes Benz Actros.
- Drive: 3/4", 32 EPL, L: 50 mm
- Impact resistant
- Application: MB Actros
- 適用於拆除輪軸螺絲
- 尺寸: Drive 3/4", 32 EPL, L: 50 mm
- 可與扭力扳手一起使用
- 適用車種: MB Actros



Dr. 3/4"

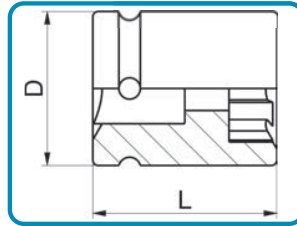

### H.C.B-A1557-90

### BENZ ACTROS AXLE BOLT SOCKET(32 EPL, L: 90 mm)

BENZ ACTROS 輪軸螺絲套筒(32 EPL, L: 90 mm)

- For removing the mounting bolts of the axle on the Mercedes Benz Actros.
- Drive: 3/4", 32 EPL, L: 90 mm
- Impact resistant
- Application: MB Actros
- 適用於拆除輪軸螺絲
- 尺寸: Drive 3/4", 32 EPL, L: 90 mm
- 可與扭力扳手一起使用
- 適用車種: MB Actros



Dr. 3/4"

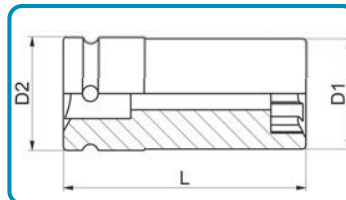

### H.C.B-A2018-26

### BENZ/HINO TRUCK OIL MIST SEPARATOR WRENCH (Dr. 1/2", 12 POINTS, 96 mm)

BENZ/HINO 卡車油水分離器扳手  
(Dr. 1/2", 12角 · 96 mm)

- Oil Filter no. :23414-E0020
- Application: BENZ/HINO TRUCK
- Size: Dr. 1/2", 12 POINTS · 96 mm
- 機油芯料號: 23414-E0020
- 適用車種: BENZ/HINO卡車
- 尺寸: Dr. 1/2", 12角 · 96 mm



Dr. 1/2"







### H.C.B-A1562

### DAF (CF) 85 COMPRESSOR REAR SEAT BEARING FIX BOLT SOCKET (11RIBS)

DAF(CF) 85空壓機後座培林固定螺絲套筒 (11齒)

- Use for remove the bolt of compressor rear seat bearing.
- Application: DAF (CF) 85
- Size: Dr. 1/2", 65 mm(L), 11ribs
- 用於拆除空壓機後座培林固定螺絲
- 適用車種: DAF (CF) 85
- 尺寸: Dr. 1/2" , 65 mm (L), 11齒



### H.C.B-A1572

### DAF (CF) DRIVE AXLE NUT SOCKET (EURO 5) (Dr. 1", 6 POINTS, 120 mm)

DAF (CF) 5期環保帶動軸螺帽套筒 (Dr. 1", 6 POINTS, 120 mm)

- To remove the drive axle nut.
- Application: DAF EURO 5
- Size: Dr. 1", 6 POINTS, 120 mm
- 使用此工具來移除帶動軸螺母。
- 適用車種: DAF EURO 5
- 尺寸: Dr. 1", 6角, 120 mm

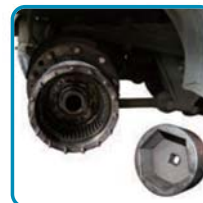
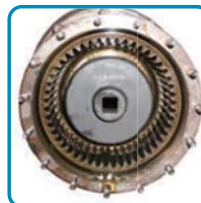
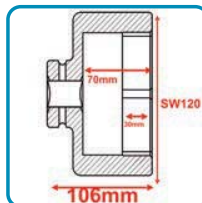

### H.C.B-A1581

### VOLVO (FM) CRANKSHAFT REAR OIL SEAL INSTALLER

VOLVO (FM) 曲軸後油封安裝器

- To prevent the crankshaft rear oil seal from damage when installing it. It is very easy to damage oil seal without using this tool.
- Application: VOLVO truck FM Year 00-07
- Oil Seal Genuine no.: 85108352
- 正確使用此工具可避免安裝時損壞油封。
- 如果未使用此工具，在更換時容易損壞到油封。
- 適用車種: VOLVO卡車 FM 年份00-07
- 油封料號: 85108352



### H.C.B-A1582

### VOLVO (FM12) TRANSMISSION OIL TUBE NUT WRENCH (74 mm)

VOLVO (FM12) 變速箱油管螺帽扳手(74 mm)

- Application: VOLVO FM12
- Size: Dr. 1/2", 6 Points, 74 mm
- 適用車種: VOLVO FM12
- 尺寸: Dr. 1/2" · 6角 · 74 mm



Dr. 1/2"





011

HWANG CHERNG BIN  
Specialty Tools Inc.

歐系卡車修護工具

European Truck Repair Tool



European Truck  
Repair Tool

### H.C.B-A1610

**NEW**

#### VOLVO (FM) CRANKSHAFT FRONT OIL SEAL INSTALLER

VOLVO(FM) 曲軸前油封安裝工具

- If you don't use special tool to install oil seal. It might causing oil seal bad installation and leak oil. Then you will need to extract and install the part again. This tool can make installing quickly and easily.
- Instruction: Put the tool on the crankshaft, hit the handle until finish installing.
- VOLVO OEM no. ref.: 88800021, 9992000
- 若無使用特殊工具安裝油封，容易造成油封安裝不均，導致漏油，並再次重新拆卸零件，重新安裝。使用此工具可快速又準確的安裝好油封。油封放上曲軸後
- 說明：裝上A1610，敲擊把柄部分，即可完成油封安裝動作
- 原廠料號：88800021, 9992000

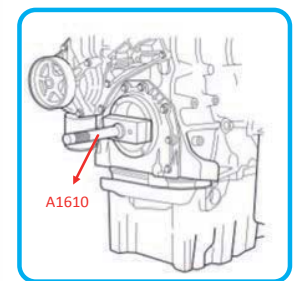

### H.C.B-A1661

**NEW**

#### BENZ TRUCK 2636 REAR WHEEL AXLE NUT SOCKET (Dr. 3/4")

BENZ 卡車2636 後輪雙軸螺母套筒 (Dr. 3/4")

- To remove the rear wheel axle nuts.
- Application: BENZ truck 2636, 2640, 414
- Year: 2006-2016
- 此工具用來移除後輪帶動軸螺母
- 適用車種: BENZ 卡車2636, 2640, 414
- 年份: 2006-2016



Dr. 3/4"

### H.C.B-A1177

#### TOYOTA ZACE/ DAF BALL JOINT EXTRACTOR (32 mm)

TOYOTA瑞獅/ DAF方向機主機球頭拔卸器(32mm)

- Pay tention to propeller shaft removal and installation. No impact, crack, and damage are allowed. No crack or damage on propeller shaft cover is permitted.
- This is powerful while break-up the ball-joint from the tie-rod end. The nut and bolt must have at least 4 to 5 teeth installed, otherwise bolt and nut might get tighten the bolt with a wrench.
- Application: TOYOTA ZACE and DAF commercial wagon, for removal of the track rod end from the drag link.
- 拆裝傳動軸時務必注意及小心，不可使用氣動扳手、或是敲擊，避免工具損壞。
- 因為從橫拉桿接頭拆除球接頭的力道強大，所以螺母螺絲至少要4~5齒安裝。另外要用扳手把螺絲螺母拴緊。
- 適用車種: TOYOTA ZACE和DAF商用貨車，用於拆除牽桿上的橫拉桿接頭。



DAF



# H.C.B-A1569

## SCANIA LIFT AXLE LUG PIN REMOVAL TOOL KIT (W/HYDRAULIC CYLINDER)

SCANIA 舉升軸吊耳插銷拆卸工具組(油壓)

- This tool is designed to remove SCANIA lift axle lug pin.
- The purpose is to change the bearing. The tool is hydraulic content, it can use with H.C.B-B1129-Hydraulic hand pump or H.C.B-A3036-Air pump.
- It will make removal of bearing convenient and save your time.
- 此工具用來拆卸SCANIA舉升軸吊耳、插銷。
- 目的為更換培林。此工具為油壓設計。可搭配H.C.B-B1129 手動幫浦(3/8" 接頭)或H.C.B-A3036 (1600 c.c.) 氣動幫浦(3/8" 接頭)一起使用。讓拆卸變得更快速、省力。



No.	品名	尺寸
1	油壓缸導管	D: Ø67x145L,d:Ø48,M57x14W
2	連接螺絲	H17x55L, M16xP2.0,M16xP1.5
3	拆卸螺帽	D:Ø45x40L,d:M35xP1.5,H22
4	拆卸座	D:Ø88x85L, d:Ø48
5	油壓缸本體	8 Tons, D: M57x14W

Parts No.	Description	Dimension
1	Hydraulic cylinder guide	D: Ø67x145L,d:Ø48,M57x14W
2	Connect screw	H17x55L, M16xP2.0,M16xP1.5
3	Removing nut	D:Ø45x40L,d:M35xP1.5,H22
4	Removing plate	D:Ø88x85L, d:Ø48
5	Hydraulic cylinder	8 Tons, D: M57x14W

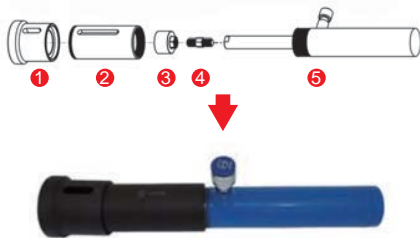

Step 1.  
Take no.2 screw into No.5 hydraulic cylinder. Connect No.3, then screw No.1 guide. Finally, connect No.4.  
步驟1.  
將2號連接螺絲鎖入5號油壓缸前端，接上3號拆卸螺帽，再轉入1號油壓缸導管，接上4號拆卸座

Step 2.  
Because the place is narrow, you need to screw the tool in to plug pin first, then connect the hand pump or air pump.  
步驟2  
由於空間狹小，先將此工具套入吊耳插銷，再裝上H.C.B-B1129 手動或H.C.B-A3036氣動幫浦

Step 3.  
Use the pump to remove the plug pin from the lift axle.  
步驟3  
做動幫浦拆卸吊耳插銷

Step 4.  
Finish the removing plug pin!  
步驟4.  
吊耳插銷拆卸完成！

### Optional Tools選購配件：



H.C.B-B1129  
Hydraulic hand pump  
(Optional)  
手動幫浦 (選購配件)



H.C.B-A3036  
Air pump (1600 c.c.)  
(Optional)  
氣動幫浦 (選購配件)





SINCE 1990

HWANG CHERNG BIN  
Specialty Tools Inc.

# 日系卡車修護工具

JAPANESE TRUCK REPAIR TOOL





### H.C.B-A1127

### FUSO REAR WHEEL NUT SOCKET(8 POINTS, 120 mm)

FUSO 卡車後輪螺帽拆裝套筒 (8角, 120 mm)

2 / 17.1 / 19 / 1.26'

- Fixing bearing in the right position while removing / installing the truck nut.
- Adjusting the nut with slide rod to adjust the tightness of bearing.
- 在拆卸或安裝卡車螺帽時，用來固定培林。
- 以滑桿調整螺帽，以控制培林的鬆緊度。

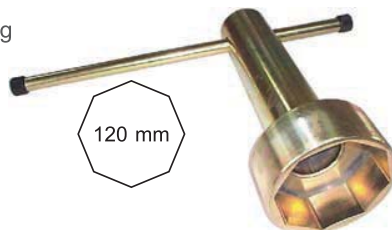

### H.C.B-A1184

### HINO CRANKSHAFT REAR OIL SEAL INSTALLER (JO8C)

HINO 卡車曲軸後油封安裝器 (JO8C)

- This tool is designed for preventing oil seal from damage when installing it.
- Application: HINO10.5/15/17 TONS
- Oil seal genuine no.: AZ4079-F
- 本工具經過特殊設計，可在安裝過程避免損傷油封。
- 適用車種：HINO10.5噸 / 15噸 / 17噸卡車。
- 油封料號：AZ 4079-F



### H.C.B-B1184

### HINO CRANKSHAFT FRONT OIL SEAL INSTALLER

HINO 卡車曲軸前油封安裝器

- This tool is designed for preventing the HINO crankshaft front oil seal from damage when installing it.
- Application: HINO truck and 35 TONS ; PROFIA K13C-TE 350P、700 series E13C 420P
- Oil seal genuine no.: AH3618-M, BZ5376E
- Tools genuine no:09407-1190
- 本工具經過特殊設計，在安裝HINO曲軸前油封時，可避免損傷油封。
- 適用車種：HINO卡車及35噸、大將K13C-TE 350P、700系列E13C 420P。
- 油封料號：AH3618-M, BZ5376E
- 工具料號：09407-1190







011

HWANG CHERNG BIN  
Specialty Tools Inc.

日系卡車修護工具

Japanese Truck Repair Tool



Japanese Truck  
Repair Tool

### H.C.B-C1184

### HINO CRANKSHAFT FRONT OIL SEAL INSTALLER (JO8C)

HINO 卡車曲軸前油封安裝器(JO8C)

- This tool is designed for preventing oil seal from damage while installing. Save time and labor
- Application: HINO 10.5, 15, 17 TONS
- Oil seal genuine no.:BZ4820E
- 使用方法：本工具經過特殊設計，可在安裝過程避免損傷油封，精確將油封裝入到適當的位置，省時又好用。
- 適用車種：HINO 10.5、15、17噸
- 油封料號：BZ4820E



### H.C.B-A1178

### FUSO/HINO PROFIA 700 STEERING MECHANISM OIL SEAL SOCKET (Dr. 1/2")

FUSO/HINO 大將 700 卡車方向機油封套筒 (Dr. 1/2")

12 / 13.8 / 15 / 1.04'

- While replacing steering mechanism oil seal, this tool is to regulate the nut and prevent nut from damage
- Application: most of Japanese truck. (ex. FUSO/HINO PROFIA 700/HINO 17 TONS)
- 在更換方向機油封時，用本工具來調整螺帽，可避免螺帽損壞。
- 適用車種：大部份日系卡車的方向機。例如：FUSO/HINO 大將 700/HINO 17噸



### H.C.B-B1178

### FUSO STEERING MECHANISM OIL SEAL SOCKET (Dr. 1/2") (UNDER 15 TONS)

FUSO 方向機油封套筒 (Dr. 1/2") (15噸以下)

- While replacing steering mechanism oil seal, this tool is to regulate the nut and prevent nut from damage.
- Application: Most of Japanese truck (Ex. FUSO under 15 TONS/3.5 TONS (Euro 4))
- 在更換方向機油封時，用此工具來調整螺帽，可避免螺帽損壞。
- 適用車種：大部分日系卡車方向機油封更換 (例如:FUSO 15噸以下/3.5噸(4期))

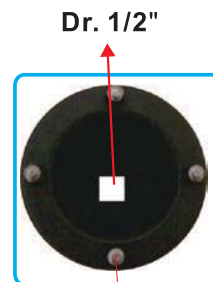

PCD 53 mm x φ5.5 x 4 points





H.C.B-C1178

NEW

FUSO CANTER (3.5 TONS) STEERING GEAR OIL SEAL SOCKET (Dr. 1/2") (EURO 4)

FUSO 堅達(3.5噸)方向機主機油封螺母套筒 (Dr. 1/2") (四期環保)

- While replacing steering mechanism oil seal, this tool is to regulate the nut and prevent nut from damaged.
- Application: FUSO Canter 3.5 tons. (Euro 4)
- 在更換方向機油封時，用此套筒來調整螺帽，可避免螺帽的損壞
- 適用車種: FUSO堅達 3.5噸 (4期)



H.C.B-A1270

HINO STEERING MECHANISM OIL SEAL SOCKET (Dr. 1/2")

HINO 方向機油封套筒 (Dr. 1/2")

- This socket is to loosen/tighten the nut when replacing steering mechanism oil seal. It could cause damage without using this tool while replacing oil seal.
- Application: For HINO truck use only. (After 1994, 21~35 tons truck.)
- 更換方向機油封之前，必須先用本工具拆下螺帽。待更換完畢後，再用本工具將螺帽裝回。若未使用工具進行拆裝，則易傷及零件。
- 適用範圍：HINO卡車（1994年以後車種，21噸~35噸）專用，方向機油封更換拆裝。

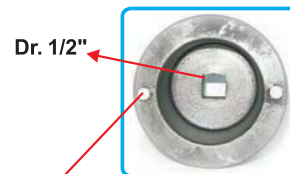

PCD 60 mm X 1/4" X 2 POINTS



H.C.B-A1210

MITSUBISHI CANTER /FUSO AXLE BALL JOINT PULLER

三菱堅達/FUSO仰角球接頭拆卸器

- Special design. Easy to use. The hooks are adjustable, suitable to different ball joints.
- For Mitsubishi Canter front wheel axle ball joint.
- Application: Mitsubishi Canter 3.5 tons, 4.4 tons and Fuso Rosa.
- 特殊設計、方便使用。可調式雙爪，適用於各種尺寸的球接頭。
- 可用於Mitsubishi Canter前輪軸球接頭。
- 適用車種：Mitsubishi堅達3.5噸、4.4噸和Fuso Rosa

 Genuine stock No.:  
Mc819642



Illustration for use



H.C.B-A1248

MITSUBISHI DELICA 2500 c.c. WHEEL NUT SOCKET (Dr. 1/2")

得利卡2500 c.c. 輪軸螺帽套筒 (Dr. 1/2")

- Socket for the wheel nut.
- Application: Mitsubishi DELICA 2500 c.c.
- 可用來拆卸輪軸螺帽。
- 適用車種：Mitsubishi得利卡2500 c.c.



Dr. 1/2"

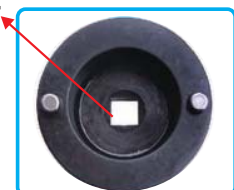

P.C.D. 60mm x φ8 x 2



011

HWANG CHERNG BIN  
Specialty Tools Inc.

日系卡車修護工具

Japanese Truck Repair Tool



Japanese Truck  
Repair Tool

### H.C.B-A1275

### HINO / ISUZU / FUSO / UD ANCHOR PIN REMOVER (HYDRAULIC)

HINO/ISUZU/FUSO/UD 剎車來令片插銷拔卸器 (油壓)

- Application: HINO/ISUZU/FUSO/UD truck.
- 適用: HINO/ISUZU/FUSO/UD 卡車.

No.	Component Name	Descriptions	Quantity
1	Cylinder	6 Tons	1
2	Cylinder Fixation	ø 67 x 48 x 145L	1
3	Cylinder Prolongation	ø 74 x 32 x 53L	1
4	M16 x P1.5 Anchor Pin Extractor	M16 x P2.0 x H17 x M16 x P1.5	1
5	M14 x P1.5 Anchor Pin Extractor	M16 x P2.0 x H17 x M14 x P1.5	1
6	M12 x P1.25 Anchor Pin Extractor	M16 x P2.0 x H17 x M12 x P1.25	1
7	M12 x P1.0 Anchor Pin Extractor	M16 x P2.0 x H17 x M12 x P1.0	1
8	M16 x P1.5 Tap	M16 x P1.5 (SKS)	1
9	M14 x P1.5 Tap	M14 x P1.5 (SKS)	1
10	M12 x P1.25 Tap	M12 x P1.25 (SKS)	1
11	M12 x P1.0 Tap	M12 x P1.0 (SKS)	1

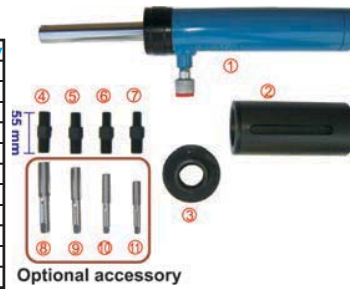

1. Connect anchor pin extractor with anchor pin and cylinder fixation.  
把來令片插銷、油壓缸固定座和來令片插銷拔卸器連結。



2. To remove anchor pin from brake by hydraulic hand pump.  
以手動幫浦施力，將插銷由來令片中拔出。



3. Take off anchor pin.  
取下來令片插銷。



4. Anchor pin and anchor pin extractor.  
來令片插銷和拔卸器示意圖。

### H.C.B-A1286

### HINO 11.9 TONS REAR WHEEL AXLE NUT SOCKET (Dr. 3/4", 8 POINTS, 105 mm)

HINO 11.9噸後輪軸螺帽套筒 (Dr. 3/4", 8角, 105 mm)

- Apply to HINO 11.9 tons truck rear wheel axle nut removal / installation.
- Size: Dr. 3/4", 8 points, 105 mm
- 拆裝HINO 11.9噸卡車後輪軸螺帽用。
- 尺寸: Dr. 3/4", 8角, 105 mm

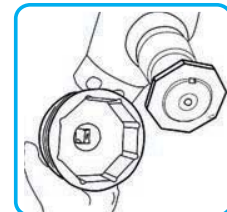

### H.C.B-B1056

### ISUZU 3.5 TONS REAR WHEEL AXLE NUT SOCKET

ISUZU 3.5 噸後輪軸螺帽套筒

- Socket for the rear wheel axle nut of ISUZU. It can be used with torque wrench for installing and removing.
- Material: S45C.
- Application: ISUZU 130 HP, 150 HP
- 此工具用來拆卸 ISUZU後輪軸螺帽
- 可以配合使用扭力扳手拆裝
- 材質: S45C
- 適用車種: ISUZU 130 HP, 150 HP





## H.C.B-A1122

### ISUZU CRANKSHAFT OIL SEAL REPLACER

ISUZU曲軸油封更換器

1 / 18.6 / 19.4 / 0.85'

- The best tool for replacing crankshaft oil seal.
- No damage to oil seal and related parts.
- Easy to use. Help to install the oil seals accurately. Save time and money.
- Application: ISUZU truck. Engine model: 4HE1,4HF1, 4HG1, 6HH1, 6HK1.
- Oil seal genuine no.: Front Oil seal BZ4365E Rear Oil seal BZ4219E
- 更換曲軸油封的最佳工具。
- 不會損傷油封及相關零件。
- 操作簡便，可正確安裝油封。
- 適用車種：ISUZU卡車引擎型號4HE1,4HF1,4HG1,6HH1,6HK1
- 油封料號：前油封BZ 4365 E、後油封BZ 4219 E



Front oil seal: BZ4365E Rear oil seal: BZ4219E

## H.C.B-A1261

### ISUZU CRANKSHAFT REAR OIL SEAL INSTALLER (3.5 TONS)

ISUZU 曲軸後油封安裝器 (3.5噸)

- This tool is specially designed for preventing the oil seal from damage when installing it.
- Oil seal genuine no.: BZ4962-E, 3-97071561
- Application: ISUZU 3.5 tons (4JB1, 4JG2) (130 HP / 150 HP) (4JG1) (4JH1)
- 經過特殊設計，可在安裝過程避免損傷油封。
- 油封料號：BZ4962-E, 3-97071561
- 適用車種：ISUZU 3.5噸卡車。(4JB1, 4JG2) (130 HP / 150 HP) (4JG1) (4JH1)



## H.C.B-B1261

### ISUZU CRANKSHAFT FRONT OIL SEAL INSTALLER (3.5 TONS)

ISUZU 曲軸前油封安裝器 (3.5噸)

- This tool is specially designed for preventing the oil seal from damage when installing it.
- Oil seal genuine no.: BZ 4961E
- Application: ISUZU 3.5 tons (4JB1, 4JG2) (130 HP / 150 HP) (4JG1) (4JH1)
- 經過特殊設計，可在安裝過程避免損傷油封。
- 油封料號：BZ 4961E
- 適用車種：ISUZU 3.5噸卡車 (4JB1, 4JG2) (130 HP / 150 HP) (4JG1) (4JH1)







Japanese Truck  
Repair-Tool

### H.C.B-A1351

### UD 350 (CK450) UD 380 (CK451) TRUCK CRANKSHAFT REAR OIL SEAL INSTALLER

UD 350 (CK450) UD 380(CK451)卡車曲軸後油封安裝器

- To prevent the crankshaft rear oil seal from damaged when installing it.
- Application: UD truck UD 350 (CK450) over 20 tons ,UD 380 (CK451)
- Oil seal genuine no.: BZ5967E
- 正確使用本工具可避免安裝時損壞油封。
- 適用車種: UD 卡車 UD350 (CK450)  
· 20噸以上 UD380 (CK451)
- 油封料號: BZ5967E

VIDEO



### H.C.B-B1351

**NEW**

### UD 17 TONS (FE6) TRUCK CRANKSHAFT REAR OIL SEAL INSTALLATION TOOL KIT

UD 17噸(FE6) 曲軸後油封安裝工具組

- To prevent the crankshaft rear oil seal from damaged when installing it.
- Application: UD truck 17 TONS (1996-211)
- Oil seal genuine no.: BZ6273E
- 使用此工具在安裝時可避免損壞後油封。
- 適用車種: UD 17噸卡車 (1996-2011)
- 油封料號: BZ6273E

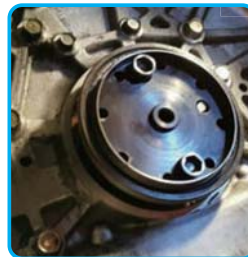

BZ6273E

### H.C.B-A1066-5

### UNIVERSAL AXLE EXTRACTOR (FOR TRUCKS ONLY)

萬用輪軸拔卸器 (卡車專用)

- N.W.: 7.5 kgs
- Specification:  $\phi$  259 x 32 mm
- Screw specification:  $\phi$  30 x 6 W
- Application: Japanese truck only.  
Ex: HINO, UD truck 180 pulley.
- 淨重: 7.5公斤
- 規格:  $\phi$  259 x 32 mm
- 螺絲規格:  $\phi$  30 x 6 W
- 適用所有日系卡車前後輪軸拆卸, 及UD卡車180皮帶盤



## H.C.B-A1397

## UD TRUCK (CW520, CW530) CRANKSHAFT REAR OIL SEAL INSTALLER

UD 卡車 (CW520, CW530) 曲軸 後油封安裝器

- To prevent the crankshaft rear oil seal from damage when installing it. It is very easy to damage oil seal without using this tools.
- Application : UD TRUCK CW520 and CW530
- Oil Seal Genuine no. : BZ5333E → CW520 · BZ4938E → CW530
- 正確使用此工具可避免安裝時損壞油封。如果未使用此工具，在更換時容易損壞到油封。
- 適用車種：UD 卡車 CW520 及 CW530
- 油封料號：BZ5333E → CW520 · BZ4938E → CW530

VIDEO



BZ 4938E



BZ 5333E

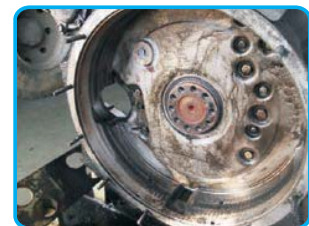
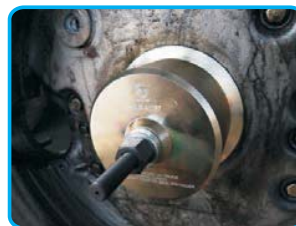
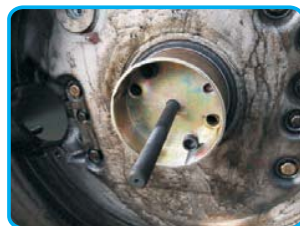

## H.C.B-C1102

## JAPANESE TRUCK BALL JOINT REMOVER (39 mm) PAT. M 362085

日系卡車球接頭拔卸器 (39 mm)

- On car maintenance.
  - The best tool for removing truck ball joint which is in tie rod end, drag link and relay rod...etc.
  - No damage to ball joint and related parts.
  - Application: Over 4 tons Japanese trucks and most of heavy duty trucks.
  - 可在車上維修。
  - 可拆卸卡車橫拉桿和轉向拉桿上的球接頭。
  - 不會損壞球接頭和相關零件。
  - 適用車種：4噸以上日系卡車，以及大部份重型卡車
- ※ Note:
- Make sure the dimension or specification of ball joint is matching before installing.
  - Please lubricate the central bolt before using.
  - The central bolt is consumable. Please replace it when losing the thread.
  - The power is very strong when ball joint departs from related parts. To prevent the parts from falling down suddenly, please loose lock nut till its surface equal to the parts instead of to take it off.
  - Please wear goggles while using this tool.



※ 注意事項:

- 連結球接頭拔卸器前，請先確認球接頭的尺寸或規格相符。
- 使用前請先潤滑中心螺絲。
- 中心螺絲是消耗品。當螺牙磨損時，請更換中心螺絲。
- 當球接頭被拔出時的瞬間力道很大。為避免相關零件掉落，請先鬆開固定螺帽直到和零件表面一樣高、而不要完全取下。
- 使用本工具時，請戴護目鏡。





011

HWANG CHERNG BIN  
Specialty Tools Inc.

日系卡車修護工具

Japanese Truck Repair Tool



Japanese Truck  
Repair Tool

### H.C.B-A1179

### PITMAN ARM PULLER (Dr. 3/4", 62 mm)

方向機搖臂拆卸器 (Dr. 3/4", 62 mm)

5 / 22.5 / 23 / 0.74'

- Put it on steering mechanism pitman arm, then take pitman arm apart.
- It is time and labor saver which is different from traditional puller. It can also prevent pitman arm from damage.
- Application: 15 tons ~ 35 tons of HINO, ISUZU, UD, FUSO truck and bus VOLVO (FM12)
- 將本工具放置到方向機搖臂上，然後取下搖臂。
- 省時、省力。和傳統式的拆卸器不同，不會損壞搖臂。
- 適用車種：15~35噸的HINO，ISUZU，UD、FUSO的卡車和遊覽車、VOLVO (FM12)



### H.C.B-A1180

### PITMAN ARM PULLER (Dr. 3/4", 47 mm)

方向機搖臂拆卸器 (Dr. 3/4", 47 mm)

6 / 23 / 23.5 / 0.72'

- Application: HINO、ISUZU、UD、FUSO, 8.8 ~ 10.5 tons truck
- It's time and labor saver which is different from traditional puller. It can also prevent pitman arm from damage.
- 適用車種：HINO, ISUZU, UD、FUSO 8.8~10.5噸的卡車。
- 省時、省力。和傳統式的拆卸器不同，不會損壞搖臂。



### H.C.B-B1181

### ISUZU, FUSO, TOYOTA SPRING PIN METAL BUSH REMOVAL/INSTALLATION TOOL KIT (HYDRAULIC)

ISUZU, FUSO, TOYOTA卡車彈簧銷拆裝工具組(油壓式)

- To replace spring pin easily.
- Money and labor saver.
- Application: ISUZU, FUSO, TOYOTA medium-sized wagon and pickup
- 可輕易地更換卡車彈簧銷。
- 省錢、省力。
- 適用車種：ISUZU, FUSO, TOYOTA 中型貨車和小卡車

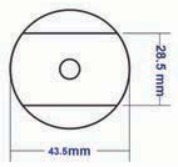

#### BUSH

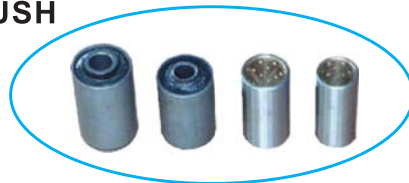

#### REMOVAL

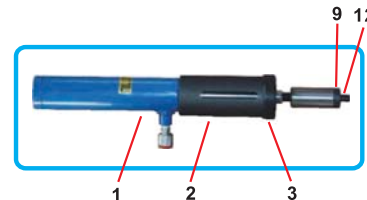
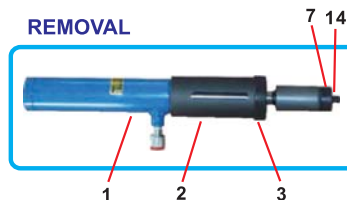

#### INSTALLATION

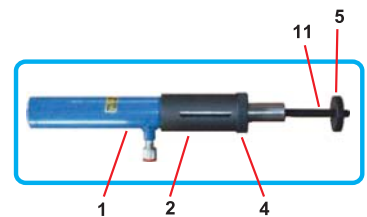
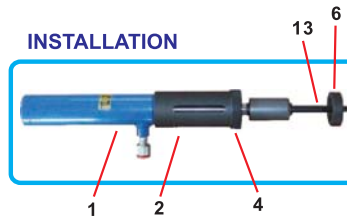



## H.C.B-A1170

## TRUCK TORQUE-ROD BUSH REMOVAL / INSTALLATION TOOL KIT PAT. M307531

卡車扭力桿鐵套拆裝工具組

1 / 54.5 / 71 / 5.8'

- Application: BPW 12, 16 tons and Japanese trucks which have torque-rod.
- 適用車種：BPW 12噸和16噸及日系卡車配備扭力桿的卡車

NO.	Description
A1170-1	SPACE RING L358XW160XH151(m/m)
A1170-2	30 TON HYDRAULIC CYLINDER (STROKE 130mm)
A1170-3	Φ103X98L RING PIVOT
A1170-4	Φ138X35L NUT (FIXED ONTO HYDRAULIC) (M88XP2.0)
A1170-5	INSERTION SUPPORT SLEEVE (Φ138X30L)
A1170-6	C-SHAPE FIXED BASE
A1170-7	TORQUE-ROD LOCK BAR (M14XP2.0)
A1170-8	TRAILER (L375XW180XH110mm)
A1170-9	AIR PUMP (OIL RESERVOIR CAPACITY 1,600 C.C.)
A1170-10	SPACE RING
	OPTIONAL
A1170-11	REPLACEMENT BASE (ø 127 x L 87)
A1170-12	INSTALLATION PLATE (ø 69 x L 83)
A1170-13	REMOVAL PLATE (ø 82 x L 32)



\*CLEANING HOLE : Clean the cinder, mud and soil out.



Ø70

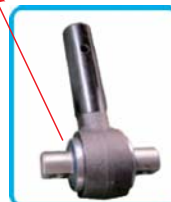

U.S.A truck  
accessory



INSTALLATION: 安裝：

- Put Torque-Rod into the main body with necessary accessories.
- Stepping on the foot plate of air pump until the bush comes out.  
(Don't obstruct the motion of air pump.)

- 把扭力桿和其他相關配件一起放入本體內。
- 輕踩氣動幫浦的腳踏板，直到鐵套被推出為止。(請勿阻礙氣動幫浦的操作。)

REMOVAL: 拆卸：

- \* Stepping on the foot plate of air pump until the bush totally combined with Torque-Rod. (Don't obstruct the motion of air pump.)

輕踩氣動幫浦的腳踏板，直到鐵套整個安裝到扭力桿為止。  
(請勿阻礙氣動幫浦的操作。)

### VIDEO



### VIDEO





011

HWANG CHERNG BIN  
Specialty Tools Inc.

日系卡車修護工具

Japanese Truck Repair Tool



Japanese Truck Repair-Tool

### H.C.B-A1338

### TRUCK VALVE REMOVER / INSTALLER

卡車氣門拆裝器

- To remove and install the valve of truck,
- Application: FUSO 3.5 tons, FUSO over 15 tons, HINO 750, ISUZU 180, ISUZU 200 and VOLVO FM truck
- 可移除和安裝卡車氣門。
- 適用車種：FUSO 3.5噸，FUSO 15噸以上，HINO 750，ISUZU 180，ISUZU 200和VOLVO FM卡車
- Specification / 規格：

Item No.	Size
A1338-1	M16 x P2.0 * M14 x P1.5 * 240mm (L)
A1338-2	M16 x P2.0 * M12 x P1.75 * 240mm (L)
A1338-3	M16 x P2.0 * M10 x P1.5 * 240mm (L)
A1338-4	M16 x P2.0 * M10 x P1.25 * 240mm (L)
A1338-5	M16 x P2.0 * M8 x P1.25 * 240mm (L)



Optional  
選購配件



### H.C.B-A1415

### HINO #700 BRAKE ADJUSTMENT WRENCH

HINO #700 煞車調整扳手

- To adjust the brake of HINO # 700 truck
- Application : HINO # 700
- 用來調整HINO #700煞車
- 適用車種：HINO #700



### H.C.B-B1415

NEW

### HINO#700 BRAKE ADJUSTMENT WRENCH

HINO #700煞車調整扳手

- To adjust the brake of HINO #700 truck.
- Combine with A1415.
- Application : HINO #700
- 與A1415配合使用。
- 適用車種：HINO # 700



### H.C.B-A1439

### JAPANESE TRUCK WHEEL NUT SOCKET

日本卡車輪軸螺帽套筒

- For removing / installing rear wheel nut.
- Material : SCM 440
- Application: JAPANESE TRUCKS, such as FUSO CANTER...etc
- 此套筒可拆裝後輪螺帽
- 材質: SCM 440
- 適用車種: 日系卡車 · 如: FUSO 堅達.....等



H.C.B-A1439-20



FUSO CANTER

Item no.	Dr.	SW	Length	N.W.	Application
A1439-17	3/4"	17mm	90 mm	0.55 KGS	
A1439-19	3/4"	19mm	90 mm	0.6 KGS	
A1439-20	3/4"	20mm	90 mm	0.612 KGS	FUSO CANTER
A1439-21	3/4"	21mm	90 mm	0.628 KGS	

## H.C.B-A1472

### FUSO TRUCK TRANSMISSION/ SHAFT SLEEVE PULLER SET

FUSO 卡車變速箱/ 軸套拆卸組

#### Features:

- The best tool to remove FUSO transmission, and shaft sleeve, which won't damage the bearing, shaft sleeve, gear and related parts
- Easy to use, and can save time and money!

#### Technical information:

- Choose the appropriate accessory before operation.
- Put accessory puller into right place of bearing or shaft sleeve, then assemble main body, finally take out spare part by rotating central bolt.
- Application: turck-FUSO

#### 特性:

- 移除FUSO變速箱、軸套的最佳工具，不會損壞培林、軸套及相關零件
- 方便操作,省時及省錢!

#### 使用方法:

- 操作前請選擇合適的配件，拆卸軸套前將拆卸塊放置軸套正確位置，再將本體轉入，之後再轉動中心螺桿就可取出。
- 適用車種：FUSO卡車



## H.C.B-A1495-1

### ISUZU PETROL OIL MIST SEPARATE WRENCH (Dr.1/2")

ISUZU 汽油油水分離器扳手 (Dr. 1/2")

- This wrench is designed to remove ISUZU Petrol filter
- Application: ISUZU FRR 90 engine & HINO 300 (EURO 5)
- 此工具用來拆卸油水分離器。
- 適用車種: ISUZU FRR90 引擎、HINO 300(5期)



## H.C.B-A1495-2

### ISUZU PETROL OIL MIST SEPARATE SOCKET (Dr.1/2")

ISUZU 汽油油水分離器套筒 (Dr. 1/2")

- This socket is designed for removing ISUZU petrol filter
- Application: ISUZU FRR 90 engine
- 此工具用來拆卸油水分離器
- 適用車種：ISUZU FRR90引擎







011

HWANG CHERNG BIN  
Specialty Tools Inc.

日系卡車修護工具

Japanese Truck Repair Tool



Japanese Truck  
Repair Tool

### H.C.B-C1491

**NEW**

### HINO (JO8C/JO8E) TRUCK INJECTION NOZZLE PULLER/ INJECTION NOZZLE SLEEVE REMOVAL/INSTALLATION TOOL KIT

HINO (JO8C/JO8E) 噴油嘴拆卸器/噴油嘴銅套拆裝工具組

- Instruction: This tool kit contains H.C.B-A1491 and H.C.B-B1491. You can remove the injection nozzle and injection nozzle sleeve only by this tool kit.
- 說明:此工具為H.C.B-A1491加上H.C.B-B1491, 使用此組工具, 讓你拆除噴油嘴後, 可接著拆卸噴油嘴銅套, 不須搭配其他工具, 即可完成兩樣工作

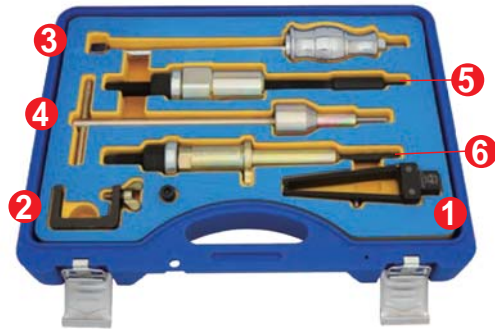

### H.C.B-B1491

**NEW**

### HINO (JO8C/JO8E) TRUCK INJECTION NOZZLE SLEEVE REMOVAL/INSTALLATION TOOL KIT

HINO (JO8C/JO8E) 噴油嘴銅套拆裝工具組

- Application: HINO (JO8C/JO8E) truck.
- This tool is designed to remove/install the injector cooper sleeve.
- Sleeve no. ref: 111761190
- 適用車種: HINO (JO8C/JO8E) 卡車
- 此工具是用來拆卸及安裝噴油嘴銅套。
- 銅套料號: 111761190

VIDEO



Sleeve no. ref: 111761190  
銅套料號: 111761190



### H.C.B-A1491

### HINO (JO8C/JO8E) TRUCK INJECTION NOZZLE PULLER

HINO (JO8C/JO8E) 卡車噴油嘴拆卸器

- This puller is designed to remove the injector.
- Application: HINO truck 300、500、700
- 此工具用來拆卸噴油嘴。
- 適用車種: HINO卡車300、500、700



HINO JO8E



HINO JO8C

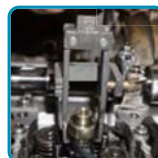
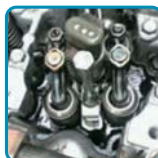



### H.C.B-A1628

**NEW**

### FUSO CANTER FUEL FILTER WRENCH (EURO 5) (Dr. 1/2") (50 mm)

FUSO 堅達柴油濾芯扳手(五期環保) (Dr. 1/2") (50 mm)

- To remove the oil filter and drain fuel from the filter.
- Application: FUSO CANTER (Euro 5), 3.5 Tons, 6.7 Tons, 6.9 Tons
- Size: Dr. 1/2" x 50 mm / 8 PT.
- 說明: 移除機油濾心蓋
- 適用車種: FUSO 堅達 (5期)、3.5噸、6.7噸和 6.9噸
- 尺寸: Dr. 1/2" x 50 mm.



### H.C.B-A1520

### Dr. 1", COMBINATION BUDD WHEEL IMPACT SOCKET (1/2" x 13/16", 41x21 mm, 38x20 mm, 35x17 mm, 33 mm) (5 PCS)

Dr. 1" 卡車輪胎套筒組  
(1/2" x 13/16", 41x21 mm, 38x20 mm, 35x17 mm, 33 mm)(5 PCS)

- **CAUTION:** Please always wear safety goggles when using impact equipment. Do not hold socket while in using
- Size: 1/2"x13/16", 41x21 mm, 38x20 mm, 35x17 mm, 33 mm
- Quality Budd wheel impact sockets are made from chrome molybdenum and designed for heavy-duty using when working on front and rear axle wheels
- **Feature/Benefits**
- Each socket distinctly etched with size which can be read easily
- 33x17 mm for TOYOTA, MAZDA, ISUZU, HINO, DAIHATSU
- 35x17 mm for NISSAN(~3t), MAZADA(~2t), ISUZU(~2t)
- 38x20 mm for MITSUBISHI(~1t)
- 41x21 mm for NISSAN(4t~), MITSUBISHI(2t~), ISUZU(4t~) HINO(4t~)
- Exotic trucks with dual rear wheels 1-1/2" socket for domestic trucks with dual rear wheels
- 注意: 在使用氣動工具時, 請穿戴護目鏡。在使用過程中, 不要緊抓套筒。
- 尺寸: 1/2"x13/16", 41x21 mm, 38x20 mm, 35x17 mm, 33 mm
- 此氣動套筒特別用在重型卡車, 可用來拆卸前輪及後輪螺絲



### H.C.B-A2313

**NEW**

### DR . 1" TRUCK WHEEL SOCKET (12PT) (41x21 mm)

DR . 1"卡車輪胎套筒 (12PT)(41x21 mm)

- Size: L=90, D1=48, D2=57, L1=15, L2=23.7 (mm) (12PT)
- 尺寸: 長=90, D1=48, D2=57, L1=15, L2=23.7 (mm) (12角)





011

HWANG CHERNG BIN  
Specialty Tools Inc.

日系卡車修護工具

Japanese Truck Repair Tool



Japanese Truck  
Repair Tool

### H.C.B-B2313

**NEW**

### DR . 1/2" TRUCK WHEEL SOCKET (12PT) (41x21 mm)

DR . 1/2" 卡車輪胎套筒(12PT) (41x21 mm)

- Size: L=110, D=56, L1=15 (mm) (12PT)
- 尺寸: 長: 110, D: 56, L1: 15, 12 角



### H.C.B-A1579

### HINO (E13C) CRANKSHAFT FRONT OIL SEAL INSTALLER (700)

HINO (E13C) 曲軸前油封安裝工具組(700 型)

- This tool is designed for preventing oil seal from damaged when installing it.
- Application: HINO (E13C) truck 390/420/446 HP (700)
- Oil seal genuine no.: BZ5221E
- Oil seal size: d:96 x Ø:131 x t:13 m/m

- 本工具經過特殊設計，在安裝HINO曲軸前油封時，可避免損傷油封
- 適用車種：HINO(E13C) 390/420/446 HP(700型)
- 油封料號：BZ5221E
- 油封尺寸: d:96 x Ø :131 x t:13 m/m



### H.C.B-B1579

### HINO (E13C) CRANKSHAFT REAR OIL SEAL INSTALLER (700)

HINO (E13C) 曲軸後油封安裝工具組(700 型)

- This tool is designed for preventing oil seal from damaged when installing it.
- Application: HINO (E13C) truck 390/420/446 HP (700)
- Oil seal genuine no.: BZ5222F
- Oil seal size :d:125 x Ø :177 x t: 15 m/m

- 本工具經過特殊設計，在安裝HINO曲軸後油封時，可避免損傷油封
- 適用車種：HINO(E13C) 390/420/44HP(700型)
- 油封料號: BZ5222F
- 油封尺寸 :d:125 x Ø :177 x t:15 m/m





H.C.B.-C1579

NEW

HINO (F20C) TRUCK CRANKSHAFT FRONT OIL SEAL INSTALLER (21 TONS)

HINO (F20C) 曲軸前油封安裝器 (21噸)

- This tool is designed for preventing oil seal from damaged when installing it.
- Application: HINO (F20C)
- Oil seal genuine no.: BZ5221E
- 本工具經過特殊設計，在安裝 HINO 曲軸前油封時，可避免損傷油封。
- 適用車種: HINO (F20C)
- 油封料號: BZ5221E



H.C.B.-A1586

HINO 11 TONS WHEEL SPEED SENSOR REMOVAL/INSTALLATION TOOL KIT

HINO 11噸輪速感應片拆裝工具

- This tool is used to remove and install wheel speed sensor.
- On car maintenance.
- Application: HINO 11 tons truck
- 此工具是用來拆裝輪速感應片
- 適用車種: HINO 11噸卡車
- 可在車上拆裝感應片



VIDEO



H.C.B.-A1625

NEW

HINO (P11C/K13C) CRANKSHAFT REAR OIL SEAL INSTALLATION TOOL KIT

HINO (P11C/K13C) 曲軸後油封安裝工具組

- To prevent the crankshaft rear oil seal from damaged when installing it.
- Application:  
HINO P11C (330 HP) (1999-2002)  
HINO K13CTV (360 HP) (1999-2002)
- Oil seal genuine no.: BZ5377F
- 說明:此工具可輕鬆安裝油封，過程不會傷害到油封或零件。
- 適用車種:  
HINO P11C (330 HP) (1999-2002)  
HINO K13CTV (360 HP) (1999-2002)
- 油封料號: BZ5377F

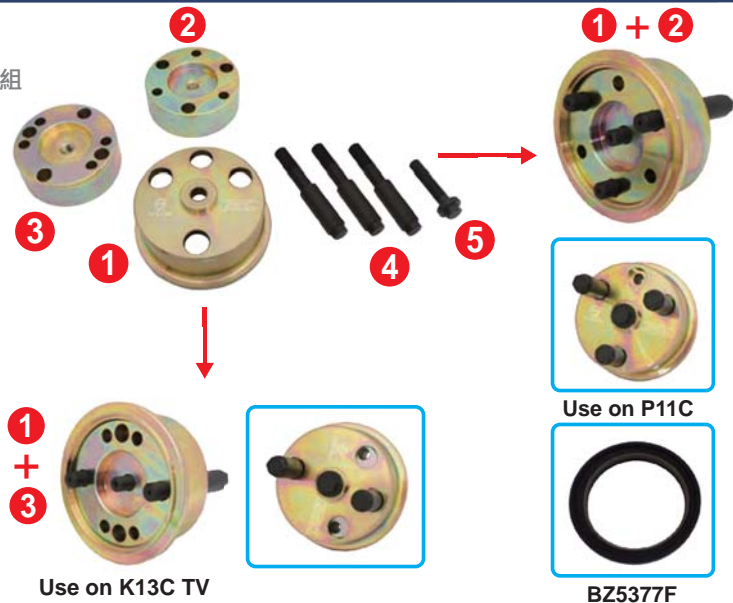



011

HWANG CHERNG BIN  
Specialty Tools Inc.

日系卡車修護工具

Japanese Truck Repair Tool



Japanese Truck Repair Tool

### H.C.B-A1635

**NEW**

### ISUZU 35 TONS (6WG1/6WA1) CRANKSHAFT FRONT OIL SEAL/FAN AXLE OIL SEAL INSTALLER

ISUZU 35 噸 (6WG1/6WA1)  
曲軸前油封及風扇軸油封安裝工具



VIDEO



Character:

- This tool is specially designed for preventing the oil seal from damaged when installing it.
- Oil seal genuine no.: BZ4837 G, BZ5016 E
- Application : ISUZU 35 tons truck
- 此工具可以安裝風扇軸油封和曲軸前油封兩種油封。  
讓你在安裝油封過程不會損壞到油封及零件。
- 油封料號: BZ4837 G, BZ5016 E
- 適用車種 : ISUZU 35 噸



BZ5016 E

風扇軸油封

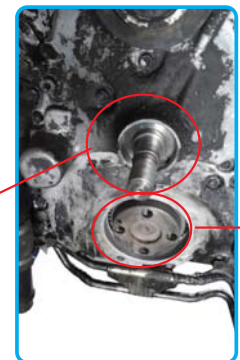

BZ4837 G

曲軸前油封

### H.C.B-A2018

### MITSUBISHI CANTER 3.5 TONS /FUSO OIL FILTER WRENCH (Dr. 1/2", 15 POINTS, 100 mm)

三菱堅達3.5噸/FUSO機油芯扳手 (Dr. 1/2" · 15角 · 100 mm)

30 / 13.5 / 15 / 1.8'

- To remove oil filter.
- Application: Mitsubishi Canter 3.5 tons /FUSO
- Size: Dr. 1/2", 15 points, 100 mm
- Genuine no.: ME013343
- 可移除機油芯
- 適用車種 : 三菱堅達3.5噸貨車
- 尺寸 : Dr. 1/2", 15角, 100 mm
- 機油芯料號 : ME013343



Dr. 1/2"



### H.C.B-A2018-1

### MITSUBISHI NEW CANTER 8.8 TONS OIL FILTER WRENCH (TURBO) (Dr. 1/2", 15 POINTS, 101mm)

三菱新堅達8.8噸機油芯扳手 (Dr. 1/2" · 15角 · 101mm)

30 / 13.5 / 15 / 1.8'

- To remove oil filter.
- Application: Mitsubishi New Canter 8.8 tons  
Delica 2200 c.c./2500 c.c.
- Size: Dr. 1/2", 15 points, 101 mm
- Genuine no.: ME013307
- 可移除機油芯
- 適用車種 : 三菱堅達8.8噸貨車  
、得利卡2200 c.c./2500 c.c.
- 尺寸 : Dr. 1/2", 15角, 101 mm
- 機油芯料號 : ME013307



Dr. 1/2"





### H.C.B-A2018-2

### HINO 15 TONS OIL FILTER WRENCH (Dr. 1/2", 16 POINTS, 108 mm)

HINO 15 噸機油芯扳手 (Dr. 1/2" · 16角 · 108 mm)

30 / 15.9 / 17 / 1.49'

- Size: Dr. 1/2", 16 points, 108 mm
- Application: Hino 15 tons before 2006
- 尺寸: Dr. 1/2", 16角, 108 mm
- 適用車種: HINO 15噸2006年前的貨車

Dr. 1/2"

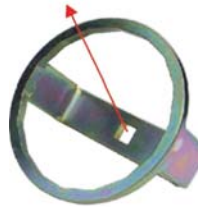

### H.C.B-A2018-5

### ISUZU ELF OIL FILTER WRENCH (Dr. 1/2", 15 POINTS, 89 mm)

ISUZU 一路發機油芯扳手 (Dr. 1/2" · 15角 · 89 mm)

30 / 11.7 / 13 / 1.8'

- Size: Dr. 1/2", 15 points, 89 mm
- Well-designed tool to save time.
- 尺寸: Dr. 1/2", 15角, 89 mm
- 經過特殊設計的工具, 節省時間、提高效率。

Dr. 1/2"



### H.C.B-A2018-11

### MITSUBISHI ALL NEW CANTER DIESEL FUEL FILTER WRENCH (Dr. 1/2", 16 POINTS, 107 mm)

三菱新堅達柴油車燃油濾清器扳手 (Dr. 1/2" · 16角 · 107 mm)

- Application: Mitsubishi all New Canter Euro 4, 3.5 tons, 6.7 tons, 6.9 tons and 14.8 tons.
- To loosen fuel filter and drain oil out.
- Before tighten filter, make sure to clean the surface and the trench of o-ring on the filter base carefully.
- Size: Dr. 1/2", 16 points, 107 mm
- N.W.: 0.644 kgs
- 適用車種: 三菱新堅達四期環保3.5噸、6.7噸、6.9噸和14.8噸柴油車
- 可鬆開燃油濾清器、並將油排光。
- 在鎖回燃油濾清器前, 請確定底部O型環溝槽已經清理乾淨。
- 尺寸: Dr. 1/2", 16角, 107 mm
- 淨重: 0.644公斤

Dr. 1/2"



### H.C.B-A2018-12

### MITSUBISHI ALL NEW CANTER DIESEL OIL AND WATER SENSOR WRENCH (12 POINTS, 54 mm)

三菱新堅達柴油車油水感應器扳手 (12角 · 54 mm)

- Application: Mitsubishi all New Canter Euro 4, 3.5 tons, 6.7 tons and 6.9 tons.
- To loosen oil and water filter and drain them out.
- Before tighten filter, be sure to clean the surface and the trench of o-ring on the filter base carefully.
- Size: 12 points, 54 mm
- N.W.: 0.224 kgs
- 適用車種: 三菱新堅達四期環保3.5噸、6.7噸和6.9噸柴油車
- 可鬆開濾油芯及濾水芯、並將油和水排光。
- 在鎖回濾油芯前, 請確定底部O型環溝槽已經清理乾淨。
- 尺寸: 12角, 54 mm
- 淨重: 0.224公斤







**H C B-A2018-13**

**HINO 17 TONS OIL FILTER WRENCH (EURO 4) (Dr. 1/2", 16 POINTS, 118 mm)**

HINO 17噸機油芯扳手 (四期環保) (Dr. 1/2", 16角, 118 mm)

- Size: Dr. 1/2", 16 points, 118 mm
- N.W.: 0.6 kgs
- Application: ISUZU、HINO 17 TONS
- 尺寸: Dr. 1/2", 16角, 118 mm
- 淨重: 0.6公斤
- 適用車種: ISUZU、HINO 17噸



**H.C.B-A2018-14**

**MITSUBISHI VERYCA (1200c.c.) OIL FILTER WRENCH (EURO 4) (14 POINTS, 66.5mm)**

中華菱利 (1200 c.c.) 機油芯扳手 (四期) (14角, 66.5 mm)

- Genuine no.: MD349105
- Application: Mitsubishi Veryca 1200 c.c.  
 Subaru Forester 2.0 / 2.5 L (2011-2016)  
 Subaru Impreza 2.0 L (2012-2016)  
 Subaru XV Crosstrek 2.0 L (2013-2016)  
 Subaru XV Crosstrek 2.0 L HYBRID (2014-2016)
- N.W.: 0.3 kgs
- 原廠料號: MD349105
- 適用車種: 中華菱利1200 c.c.
- 淨重: 0.3公斤

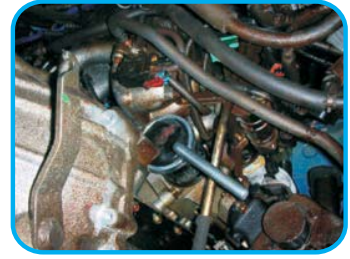

**H.C.B-A2018-17**

**FUSO (6.5/6.8/7.7 TONS) TRUCK OIL FILTER WRENCH (Dr. 1/2", 16 POINTS, 106.5 mm)**

FUSO(6.5/ 6.8/ 7.7噸) 卡車機油芯扳手 (Dr. 1/2", 16角, 106.5mm)

- Application: FUSO 6.5/6.8/7.7 tons truck
- 適用車種: FUSO 6.5/6.8/7.7噸卡車

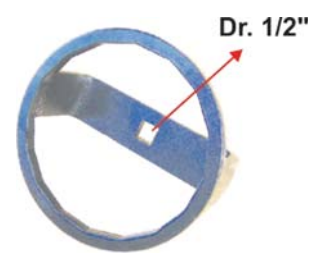

**H.C.B-A2018-18**

**FUSO (10.5~17 TONS) TRUCK OIL FILTER WRENCH (Dr. 1/2", 15 POINTS, 119 mm)**

FUSO(10.5~17噸) 卡車機油芯扳手 (Dr. 1/2", 15角, 119 mm)

- Genuine no.: ME 074013
- Application: FUSO 10.5~17 tons truck
- 原廠料號: ME 074013
- 適用車種: FUSO 10.5~17噸卡車



**H.C.B-A2018-20**

**FUSO TRUCK OIL MIST SEPARATOR WRENCH (Dr. 1/2", 8 RIBS, 109 mm)**

FUSO卡車油水分離器扳手 (Dr. 1/2", 8齒 · 109mm)

- Application: FUSO 380 over 17 tons (Engine no. 6M70) and bus. Mitsubishi all NEW CANTER eco-4 3.5, 6.7 and 6.9 tons.
- 適用車種：FUSO 380卡車17噸以上 (引擎號碼：6M70) 及遊覽車。三菱新堅達4期 環保3.5、6.7和6.9噸。



PA66-GF30

Dr. 1/2"

**H.C.B-A2018-21**

**HINO TRUCK / ISUZU 3.5 TONS (EURO 4) OIL MIST SEPARATOR WRENCH ( Dr. 1/2", 8 RIBS, 107 mm)**

HINO卡車/ISUZU 3.5噸(四期環保車)油水分離器扳手 (Dr. 1/2", 8齒 · 107mm)

- Application: HINO truck year 2003~2006 or after year 2010/ISUZU 3.5 tons (Euro 4)
- Genuine no.: 103251, S23401-11840-A
- 適用車種：2003-2006年或2010年後的HINO卡車/ISUZU 3.5噸(四期環保車)
- 原廠編號：103251，S23401-11840-A

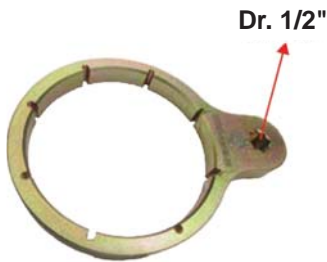

Dr. 1/2"



**H.C.B-A2018-22**

**ISUZU (4.9~7.9 TONS) TRUCK OIL FILTER WRENCH (Dr. 1/2", 15 POINTS, 118 mm)**

ISUZU (4.9~7.9噸)卡車機油芯扳手 (Dr. 1/2", 15角, 118 mm)

- Application: ISUZU (4.9 TONS~7.9 TONS) TRUCK
- 適用車種：ISUZU (4.9 ~7.9噸)卡車



Dr. 1/2"



**H.C.B-A2018-23**

**HINO(EURO 4) (3.5 ~7.4 TONS) TRUCK OIL FILTER WRENCH (Dr. 1/2", 15 POINTS, 101.5 mm)**

HINO(四期) (3.5 ~7.4 噸)卡車機油芯扳手 (Dr. 1/2", 15 角, 101.5 mm)

- Application: HINO (EURO 4) (3.5 tons~7.4 tons) truck
- 適用車種：HINO(四期) (3.5 ~7.4噸) 卡車



Dr. 1/2"





011

HWANG CHERNG BIN  
Specialty Tools Inc.

日系卡車修護工具

Japanese Truck Repair Tool



Japanese Truck  
Repair Tool

### H.C.B-A2018-24

### FUSO (6D16) MEDIUM-SIZED TRUCK OIL FILTER WRENCH (Dr. 1/2", 16 POINTS, 123 mm)

FUSO (6D16)中型卡車機油芯扳手  
(Dr. 1/2", 16角, 123 mm)

- Oil Filter no. : ME130968/ME074013
- Application : 2005-2008 FK200  
2005-2007 FM260/AS  
2005-2008 FM330  
2008 FK260

- 機油芯料號 : ME130968/ME074013
- 適用車種 : 2005-2008 FK200  
2005-2007 FM260/AS  
2005-2008 FM330  
2008 FK260



Dr. 1/2"



Genuine no.: ME130968 ME074013

### H.C.B-A2018-25

### FUSO (6D16) 11 TONS REMOVAL TOOL FOR FUEL FILTER (Dr. 1/2", 15 POINTS, 93 mm)

FUSO (6D16) 11 噸柴油濾芯扳手  
(Dr. 1/2" , 15角, 93 mm)

- Application: FN428, FP413, 415, 418 / FT413, 415 / FU413, 415, 418, 478, K303, 405 / FS418 / MU515
- Oil Filter no. : ME056670
- Size: Dr. 1/2", 15 Points, 93 mm
- 適用車種: FN428, FP413, 415, 418 / FT413, 415 / FU413, 415, 418, 478, K303, 405 / FS418 / MU515
- 機油芯料號: ME056670
- 尺寸: Dr. 1/2" , 15角, 93mm



Dr. 1/2"

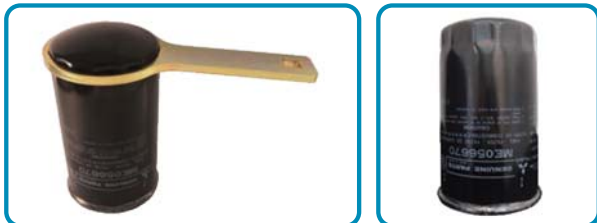

### H.C.B-A2130

### MITSUBISHI CANTER DIESEL OIL FILTER REMOVER/ INSTALLER

三菱堅達柴油車機油芯拆裝工具

- This tool set includes H.C.B-A2130-1 diesel oil filter wrench x 1 and H.C.B-A2130-2 diesel oil filter switch wrench x 1
- Application: MITSUBISHI CANTER and most of diesel engine.
- Genuine no.: MB 220900
- 本工具組包含H.C.B-A2130-1柴油機油芯扳手、H.C.B-A2130-2柴油機油芯開關扳手各1支
- 適用車種：三菱堅達及大部份柴油引擎貨車
- 原廠料號：MB 220900



FUEL FILTER  
GENUINE STOCK NO.: MB220900







SINCE 1990

HWANG CHERNG BIN  
Specialty Tools Inc.

# 通用卡車修護工具

GENERAL TRUCK REPAIR TOOL



**H.C.B-A1102**
**TRUCK BALL JOINT REMOVER (39 mm) PAT. M 362085**

卡車球接頭拆卸器 (39 mm)

**10 / 24 / 26.5 / 1'**

- On car maintenance.
- The best tool for removing truck ball joint.
- Won't damage ball joint and related parts.
- Easy to use. Save time and money.
- Specification: nut width 26 mm, bolt length 128 mm
- Application: over 4 tons truck, and most of trucks, for example SCANIA, BENZ, MAN, HINO ... etc.
- 免拆零件、可車上維修。
- 拆卸球接頭的利器。
- 不會損壞球接頭及相關零件。
- 操作簡便。省時又省錢。
- 規格：螺帽寬-26 mm，螺桿長-128 mm
- 適用車種：4噸以上的卡車。例如：SCANIA，BENZ，MAN，HINO...等。

**Technical information**

- Thoroughly lubricate the bolt.
- Use the low RPM to rotate, tighten the bolt while using the air wrench at the beginning.
- Use a hammer to hit the central screw on the tool in order to separate the ball joint.

**使用方式：**

- 使用前請先潤滑中心螺絲。
- 使用氣動扳手旋緊中心螺絲時，一開始請用低轉速。
- 可用錘子敲打中心螺絲，以將球接頭從零件中取下。

**Special design Ball Screw**  
 特殊設計鋼珠螺絲

**H.C.B-A1112**
**MEDIUM-SIZED WAGON BALL JOINT EXTRACTOR (32 mm) PAT.**

中型貨車球接頭拆卸器 (32 mm)

**10 / 26.8 / 29 / 1'**

- Application : 3.5~8.8 tons truck
- 適用車種：3.5~8.8噸卡車

**Application: 3.5 tons ~ 8.8 tons trucks**
**H.C.B-A1407**
**UNIVERSAL TRUCK BALL JOINT REMOVER (32 mm)**

萬用球接頭拆卸器 (32 mm)

- To remove the ball joint of tie rods.
- On car maintenance.
- Best tool for removing truck ball joint.
- Won't damage ball joint and related parts.
- Easy to use. Save time and money.
- Application : Japanese trucks under 10.5 TONS such as HINO、UD、ISUZU and FUSO, especially works great on HINO 500.

- 可用來移除橫拉桿、直拉桿的球接頭。
- 免拆除零件，可車上維修。
- 不會損壞球接頭及相關零件。
- 操作簡易、省時、省力又省錢。
- 適用車種：10.5噸以下的日系卡車。
- 例如：HINO、UD、ISUZU和FUSO。且特別適用於HINO 500的卡車

**HINO 500**





通用卡車修護工具

General Truck Repair Tool



011

HWANG CHERNG BIN  
Specialty Tools Inc.



### H.C.B-A1165

### PICKUP TRUCK & BUS BALL JOINT EXTRACTOR (30 mm)

小型卡車、遊覽車球頭拔卸器 (30 mm)

20 / 21 / 22 / 1.48'

screw size:  
22Tr x P3.0

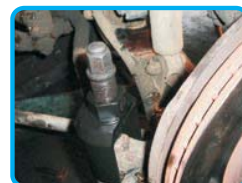

TOYOTA DYNA

- For removing the tie rod end from the drag link.
- On car maintenance.
- The best tool for removing light truck ball joint.
- Easy to use. Save time and money
- Application: All light trucks. Such as BMW (E39), Benz (W203/W210/W211/W220/W221), Mitsubishi Delica, Canter, Toyota Dyna.
- 可用來移除方向機橫拉桿上的球接頭。
- 免拆零件、可車上維修。
- 拆卸小型卡車球接頭的利器。
- 操作簡便。省時又省錢。
- 適用車種：所有小型的卡車。例如：BMW (E39), Benz (W203/W210/W211/W220/W221), Mitsubishi Delica, Canter, Toyota Dyna

#### Technical information

- Make sure the dimension or specification of ball joint match before installing.
- Tighten the bolt by wrench. Hitting the central screw on the tool in order to separate the ball joint.

#### 使用方式：

- 連結球接頭拔卸器前，請先確認球接頭的尺寸或規格相符。
- 請用扳手鎖緊螺絲，再用錘子敲打中心螺絲，以將球接頭從零件中取下。

### H.C.B-A1410

### UNIVERSAL TRUCK BALL JOINT REMOVER (39 mm) PAT.438423

萬用球接頭拔卸器 (39 mm)

- To remove the ball joint of tie rods, drag links and steering knuckle.
- On car maintenance.
- Best tool for removing truck ball joint.
- Won't damage to ball joint and related parts.
- Easy to use. Save time and money.
- Application: Most of trucks over 15 tons such a SCANIA, VOLVO, DAF, HINO, UD, ISUZU and FUSO.
- 可用來移除橫拉桿、直拉桿的球接頭。
- 免拆除零件，可車上維修。
- 不會損壞球接頭及相關零件。
- 操作簡易、省時、省力又省錢。
- 適用車種：所有15噸以上的卡車。例如：SCANIA, DAF, VOLVO, HINO, UD, ISUZU 和 FUSO



VIDEO

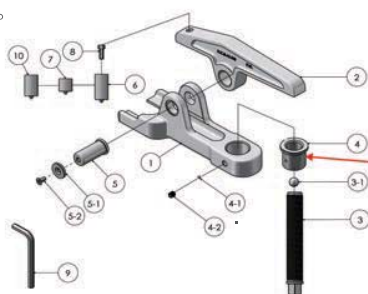

Ø35  
TM24xP3.0



DAF 42 TONS TRUCK





H.C.B-C1410

UNIVERSAL TRUCK BALL JOINT REMOVER (39 mm)  
(W/HYDRAULIC SPINDLE) PAT.438423

萬用球接頭拆卸器 (39 mm)油壓桿

- It is the best tool to remove the ball joint.
- Application: Most of the truck which is over 15 tons. Example: SCANIA, VOLVO, DAF, MAN, HINO.
- 拔除球接頭的最佳工具。
- 適用車種：超過15噸的大部分卡車，例如：SCANIA、VOLVO、DAF、MAN、HINO、UD、ISUZU、Renault和FUSO。



VIDEO

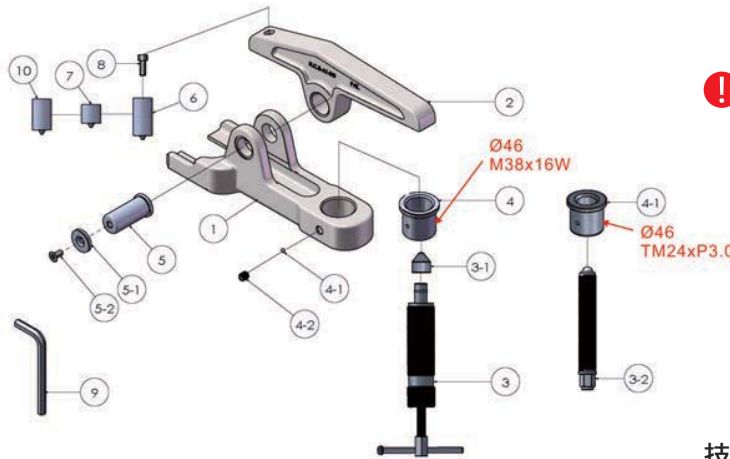

If hydraulic pressure is over 8 tons,  
you'll need to use screw.

⚠ 油壓只能至8噸，如超過8噸，需使用螺絲。

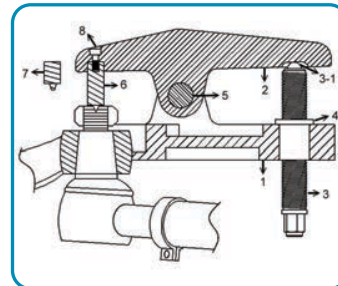

- The tool is used to remove the ball joint of tie rod and drag link.
- Used with low-speed impact wrench.
- With this tool, you can repair on car.
- This tool won't damage the ball joint and related parts.
- Easy to operate and save time and money.
- Material: SCM 440. Made by forged.
- There are two different adaptors that you can choose the appropriate adaptor according to the different ball joint.
- 用來拔除轉向橫拉桿、直拉桿以及轉向座的球接頭工具。
- 搭配低轉速氣動扳手使用。
- 車上維修。
- 此工具較不會傷到球接頭及相關配件。
- 操作容易，省時省力！
- 材質：SCM440和鍛造。
- 附兩個長短接頭，依據不同的球接頭長度選擇適當接頭配件。

技術資訊 Instructions

- Before using this tool, please remove the safety pin.
- Then loosen the nut, (only loosen instead of taking the nut out), let the nut parallel to the screw. It can prevent the bar from falling and hurt the worker .
- Before using the tool, please lubricate the screw.
- Using the hammer to hit the top of screw to separate the ball joint.
- 使用工具之前，先移除安全銷。
- 之後鬆開螺母（僅鬆開不需整個拿起）與螺桿平行，這樣一來，可以避免拉桿掉落，傷到人員。
- 使用前，螺桿需抹油。
- 使用鐵槌敲打工具上的螺桿頂端，來分開球接頭。

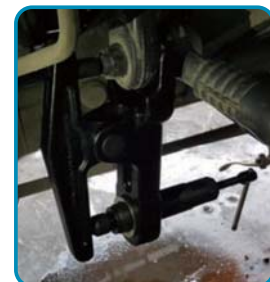



通用卡車修護工具

General Truck Repair Tool



011

HWANG CHERNG BIN  
Specialty Tools Inc.



### H.C.B-A1082-1

### UNIVERSAL BALL JOINT SEPARATOR (SCREW REPLACEABLE) (24 mm) PAT. 208928

萬用球接頭拆卸組(可替換螺絲)(24 mm)

30 / 24.2 / 25.7 / 1.18'

- Splitting the ball joint from track-rod ends and anti-roll bar ...etc. Especially in confined space.
- Application: AUDI, VW, BMW, Ford, MERCEDES-BENZ (W170/W202/W210/W220), OPEL, VAUXHALL, MITSUBISHI...etc.
- 可拆卸方向機、橫向穩定桿支架球接頭。特別是在狹小的空間中的球接頭。
- 適用車種：AUDI, VW, BMW, Ford, MERCEDES-BENZ (W170/W202/W210/W220), OPEL, VAUXHALL, MITSUBISHI 等。



### H.C.B-B1182

### UNIVERSAL TRUCK BALL JOINT PULLER (REPLACEABLE) (24 mm & 32 mm) - IMPROVEMENT

萬用卡車可換式球接頭拆卸器(24 mm & 32 mm) - 改良型

PAT. M 384746



- Time and labor saver
- This is an unique replaceable truck ball joint puller. There is the anti-load lubricant stored inside the tool to facilitate the rotating of the screw
- Application: most truck
- 經過特殊設計的可換式卡車球接頭拆卸工具。內部儲存耐高壓牛油、以螺桿推動，可達省力及省時的作動方式。
- 適用車種：所有卡車

### H.C.B-A1225

### TRUCK BALL JOINT PULLER (32 mm) (HYDRAULIC)

卡車球接頭拆卸器(32 mm)(油壓式)

- On car maintenance.
- The best tool for removing truck ball joint.
- Won't damage ball joint and related parts.
- Application: 3.5 tons medium-sized wagon ~ 8.8 tons small-sized truck.
- 可在車上維修。
- 拆卸卡車球接頭最佳的工具。
- 不會損壞球接頭和相關零件。
- 適用車種：3.5噸中型貨車~8.8噸小型卡車。



### H.C.B-A1226

### TRUCK BALL JOINT PULLER (39 mm) (HYDRAULIC)

卡車球接頭拆卸器(39 mm)(油壓式)

- On car maintenance.
- The best tool for removing truck ball joint.
- Won't damage ball joint and related parts.
- Application: 4 tons truck and most of trucks.  
For example SCANIA, BENZ, MAN, HINO ... etc.

- 可在車上維修。
- 拆卸卡車球接頭最佳的工具。
- 不會損壞球接頭和相關零件。
- 適用車種：4噸和大部份的卡車。  
例如：SCANIA, BENZ, MAN, HINO...等。





## H.C.B-A1009

## AUTOMATIC TRANSMISSION CLUTCH SPRING COMPRESSOR

自動變速箱離合器壓板拆裝工具

- For removing and installing the transmission rear clutch piston snap ring.
- This tool is adjustable and suitable for most of American cars and light trucks.
- 可移除和安裝後離合器活塞環。
- 可調整式的設計，適用於大部分的美系車輛及輕型卡車。



## H.C.B-A1120

## TRUCK TRANSMISSION BEARING PULLER

卡車變速箱培林拆卸組

1 / 19.8 / 20.6 / 0.85'

VIDEO



- The best tool for removing truck transmission bearing.
- Won't damage the bearing and related parts.
- Easy to use. Save time and money.
- Application: 4 tons and above truck  
#311 can be used on DAF ZF 12S

### Technical information

- Choose the appropriate accessory before operation.
- Press the central screw against the shaft-end by hand when installing the transmission bearing.
- The fixed ring can ensure two sleeves of the tools are securely installed on the groove of the bearing.

- 移除卡車變速箱培林的最佳工具。
- 不會損壞培林及相關零件。
- 方便使用，省時又省錢。
- 適用車種：4噸和以上的卡車  
配件#311可以使用在DAF ZF 12速

### 使用方式：

- 操作前請選擇合適的配件。
- 安裝培林前，請用手把中心螺絲抵在卡車培林的軸端。
- 固定環可確保工具的套管安置在培林的溝槽上。





通用卡車修護工具

General Truck Repair Tool



011

HWANG CHERNG BIN  
Specialty Tools Inc.



### H.C.B-A1120-308

### ISUZU TRUCK TRANSMISSION BEARING PULLER (OPTIONAL ACCESSORY)

ISUZU 卡車變速箱培林拆卸組(選購配件)

- Combine with H.C.B-A1120
- 搭配H.C.B-A1120使用



### H.C.B-A1120-309

### HINO KUOZUI 15 TONS TRUCK TRANSMISSION BEARING PULLER (OPTIONAL ACCESSORY)

HINO 國瑞15噸卡車變速箱培林拆卸組(選購配件)

VIDEO



- Add H.C.B-A1120-311 on the top of HINO KUOZUI 15 tons truck transmission and H.C.B-A1120-309 on the other end.
- 將H.C.B-A1120-311放在HINO KUOZUI 15噸卡車的變速箱上，再將H.C.B-A1120-309放在另一端。



BEARING



### H.C.B-A1120-310

### SCANIA TRUCK TRANSMISSION BEARING PULLER (OPTIONAL ACCESSORY)

SCANIA 卡車變速箱培林拆卸組(選購配件)

VIDEO



- Combine with H.C.B-A1120
- 搭配H.C.B-A1120使用



BEARING





**H.C.B-B1120**

**TRUCK TRANSMISSION BEARING PULLER**

中型貨車變速箱培林拆卸器

**H.C.B-B1120-A**

**FUSO TRUCK LAY SHAFT BEARING PULLER**

FUSO 卡車副軸培林拆卸組

**H.C.B-B1120-B**

**ISUZU 6.8 TONS TRUCK MAIN SHAFT BEARING PULLER**

ISUZU 卡車6.8噸主軸培林拆卸組

**H.C.B-B1120-C**

**ISUZU MEDIUM TRUCK BEARING PULLER**

ISUZU 中型卡車培林拆卸組



**Features:**

- The best tool for removing truck transmission bearing.
- Won't damage the bearing and related parts.
- Easy to use. Save time and money.

**Technical information:**

- Choose the appropriate accessory before operation.
- Press the central screw against the shaft-end by hand when installing the transmission bearing.
- The fixed ring can ensure two sleeves of the tools are securely installed on the groove of the bearing.
- Application: 3.5 tons-8.5 tons trucks
- B1120-306 (Bearing no.: A6306N) puller : Used on FUSO main shaft
- B1120-307 (Bearing no.: B6307N) puller : Used on ISUZU 6.8 Tons lay shaft

**Optional :**

- B1120-A (Bearing no.: 63-28 JNR) puller : Used on FUSO lay shaft
- B1120-B (Bearing no.: 6209NR) puller : Used on ISUZU 6.8 Tons Main shaft
- B1120-C (Bearing no.: 35TM03NX) puller : Used on ISUZU Medium trucks

**特性:**

- 移除卡車培林的最佳工具
- 不會損壞培林及相關零件
- 方便使用，省時又省錢

**使用方法:**

- 操作前請選擇合適的配件
- 拆卸培林前，請用手把中心螺絲抵在卡車培林的軸端。
- 固定環可確保工具的套管安置在培林的溝槽上。
- 適用車種: 3.5-8.5噸的中小貨卡
- 306 (培林編號A6306N) 適用於 FUSO 主軸
- 307 (培林編號B6307N) 適用於 ISUZU 6.8 噸副軸

**選購配件:**

- B1120-A (培林編號63-28J NR) 適用於 FUSO 副軸
- B1120-B (培林編號6209NR) 適用於 ISUZU 6.8 噸主軸
- B1120-C (培林編號35TM03NX) 適用於 ISUZU 中型車

選購配件 : A.B.C

Optional puller: A.B.C



B1120-A B1120-B B1120-C

**Bearing**



6307N 6306N





# 通用卡車修護工具

General Truck Repair Tool



# 011

HWANG CHERNG BIN  
Specialty Tools Inc.



## H.C.B-A1183

## TRUCK THREAD CORRECTOR

卡車可換式螺紋修正器

4 / 25 / 26 / 0.69'

European: SCANIA front wheel  
BPW trailer 16 tons > M60 x P2.0  
European: SCANIA back wheel

Renault 10 wheels trail (P370) drive axle > M85 x P2.0  
Japanese: FUSO, HINO, NISSAN, ISUZU  
back wheel

Renault (370HP) > M83 x P2.0

Optional: (以下為選購配件)

- (1) ROR trailer M65 x P1.5
- (2) YORK trailer 2 1/2 x 16 UNC
- (3) BPW trailer 12 tons > M52 x P2.0  
UD over 10.5 tons front wheel
- (4) FUSO M91-M95 x P2.0
- (5) HINO over 15 tons & trailer front wheel  
UD under 10.5 tons front wheel  
FUSO 8.8 tons & 10.5 tons front wheel  
MAN 410/414 front wheel } M40 x P1.5
- (6) FUSO 15/20 tons & trailer front wheel M48 x P1.5
- (7) VOLVO FL10 front wheel M52 x P1.5
- (8) KW truck rear axle (UNC 3 1/4 x 12 W)
- (9) ROR trailer axle (UNC 2 5/8 x 16W)
- (10) BENZ 2640 (M80 x P1.5)
- (11) BENZ 2640 (EXTRA)(M100 x P1.5)
- (12) FUSO, HINO (10.5 tons) rear wheel (M65 x P2.0)
- (13) DAF (CF85) rear drive axle (M86~M90 x P2.0)
- (14) DAF(CF85) front wheel (M66~M70 x P1.5)
- (15) DAF(CF85) front wheel (M56~M60 x P1.5)
- (16) ROR disc brake 3 1/2"x12 UNC

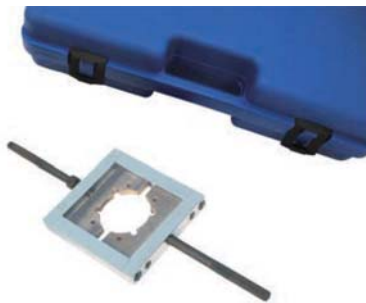

### VIDEO

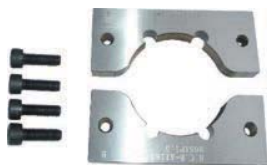

Material (材質) : SKD11  
Hardness (硬度) : HRC60°~62°



Warning : 注意 :

Clean the trailer axle before operating .  
After lubricating the axle, then correct the thread  
from inside to outside

使用工具前必須先清洗輪軸，上機油後由內向外使用

## H.C.B-A1187

## PNEUMATIC BRAKE LINING SHOE LOADER

卡車剎車來令拆裝機(氣壓式)

- Maximum Capacity : 600 kgs
- Maximum PSI : 8500
- Protect the brake shoe steel.
- This machine is actuated by pneumatic power which is quick and easy to use.
- To fasten and secure firmly than using the riveter.
- 使用時可避免煞車蹄鋼片受損。此機器以氣壓動作，方便快速，較傳統鉚釘機安全，工具多種尺寸可供選擇。

### VIDEO







General Truck Repair Tool

### H.C.B-C1181

### TRUCK SPRING PIN METAL BUSH REMOVAL/INSTALLATION TOOL KIT (HYDRAULIC)

卡車彈簧銅套/插銷拆裝工具組(油壓式)

- Component No. 4~7, 9~11 is applicable to SCANIA & VOLVO trucks.
- Component No. B4, B6~B14 is applicable to ISUZU, FUSO, TOYOTA Medium-Sized Wagon & Pickup.
- To replace spring pin more easily. Money and labor saver.
- Optional accessory: H.C.B-B1129 HYDRAULIC HAND PUMP.

- 配件4~7, 9~11適用於SCANIA和VOLVO卡車。
- 配件B4, B6~B14適用於ISUZU, FUSO, TOYOTA中型貨車及卡車。
- 可輕鬆地更換彈簧銷, 省錢又省力。
- 選購配備: H.C.B-B1129手搖幫浦



VIDEO



選購配件  
Optional



### H.C.B-D1181

### TRUCK SPRING PIN METAL BUSH REMOVAL/INSTALLATION TOOL KIT(17 TONS HYDRAULIC CYLINDER)

卡車彈簧銷拆裝工具組(17噸油壓式)

- Money and labor saver.
- Powerful 17 tons hydraulic cylinder helps to remove stubborn spring pins easily.
- 操作省錢又省力。
- 使用強力的17噸油壓缸, 可輕易地移除卡住的彈簧銷。



VIDEO



OPTIONAL FOR VOLVO FM12

### H.C.B-E1181

### TRUCK SPRING PIN METAL BUSH REMOVAL/INSTALLATION TOOL KIT

卡車彈簧銷拆裝工具組

- **Features :**  
Due to the fact that most of European trucks manufacturer design special spring eye bush to prevent the bush from loosening, it results in the difficulty to repair or replacement if without special tools. We create this master kit to solve your problem. Save your time, labor and money!
- Application: VOLVO (FM12), RENAULT (430/450/460), MAN-TGA (410/414/460) DAF (LF/CF)

■ 說明：  
因現在歐系各大車廠, 所設計的卡車彈簧銷鐵套都是有開口的防鬆鐵套, 拆除安裝不易所以更需要此工具組, 省時、方便、有效率。

- 適用車種:  
VOLVO (FM12), RENAULT (430/450/460), MAN-TGA (410/414/460) DAF (LF/CF)



VIDEO

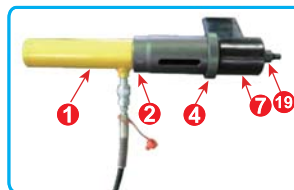

VOLVO FM12 Spring Eye Bush Replacement



DAF Part





通用卡車修護工具

General Truck Repair Tool



011

HWANG CHERNG BIN  
Specialty Tools Inc.



## H.C.B-F1181

**NEW**

### TRUCK SPRING PIN METAL BUSH REMOVAL / INSTALLATION TOOL KIT (17 TONS HYDRAULIC CYLINDER)

卡車彈簧銷拆裝工具組 (17噸油壓式)

- Powerful 17 tons hydraulic cylinder helps to remove the stuck spring pins easily.
- The hydraulic cylinder in this kit has a special non-threaded design which makes the operation easier because the screw can be quickly turned in and fixed on the cylinder
- 使用強力的17噸油壓缸，可輕易地移除卡住的彈簧銷。
- 與D1181不同的是，這組所搭配的油壓缸內為無牙特殊設計，在操作的過程，可以快速的將螺絲轉入固定，使用上更迅速、輕鬆。



VIDEO



Caution: To avoid danger, DO NOT stand behind the hydraulic cylinder while operating.  
注意：操作過程中，使用者請勿站在油壓缸後面，避免發生危險。



Removal



Installation

## H.C.B-A1665

**NEW**

### UNIVERSAL HYDRAULIC PRESSURE KIT

通用油壓組

- With easy spring reset
- Hydraulic cylinder with thread and protective cap (3/8NPT thread)
- Operating pressure: 700 bar
- Stroke length: 45 mm
- Outer diameter: 80 mm
- Hydraulic cylinder: 17.5 tons.
- 可輕鬆安裝彈簧插銷
- 接頭: 3/8"
- 壓力: 700 bar
- 行程: 45 mm
- 外徑: 80 mm
- 油壓缸: 17.5噸



## H.C.B-A1191

### UNIVERSAL BALL JOINT SEPERATOR (22 mm)

萬用球接頭拆裝工具組 (22 mm) (橫拉桿)

- Splitting the ball joint from track-rod and anti-roll bar..etc. Especially in confined space.
- 可拆卸方向機、橫向穩定桿支架球接頭。特別是在狹小的空間中的球接頭。



General Truck Repair Tool





011

HWANG CHERNG BIN  
Specialty Tools Inc.

通用卡車修護工具

General Truck Repair Tool



General Truck  
Repair Tool

### H.C.B-A1222

### UNIVERSAL CRANKSHAFT PULLEY EXTRACTOR

萬用卡車曲軸皮帶盤拆卸器

- For removing the pulley of trucks and installing new crank oil seal.
- This tool helps to take apart the rusted drive shaft and remove the hub.
- Application: Most of Japanese and European trucks. Such as HINO 20 tons, old and new 35 tons, SCANIA, Benz and VOLVO...etc.
- 可用於移除卡車曲軸皮帶盤，且安裝新的油封。
- 本工具可用來拆開生鏽的傳動軸，取出車殼。
- 適用車種：大部份的日系和歐系卡車。  
例如：HINO 20噸，舊、新款35噸，SCANIA，Benz和VOLVO...等卡車。

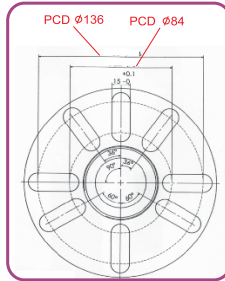

### H.C.B-A1279

### UNIVERSAL AXLE NUT REMOVAL/INSTALLATION TOOL KIT

萬用型輪軸螺帽拆裝組

- To loosen and tighten the rear wheel nut.
- Pins on both sides are adjustable.
- Aim central hole at the center of hub and then use with wrench.
- Different sizes of pins are suitable for different kinds of truck.
- Application: over 2 tons vehicles with circular nuts.
- 可用來鬆開及鎖緊後輪軸螺帽。
- 雙邊的銷都可以調整。
- 將中心孔對準輪軸中心，再配合扳手使用。
- 不同尺寸的銷可用於不同的車系。
- 適用車種：2噸以上圓形螺帽的車輛

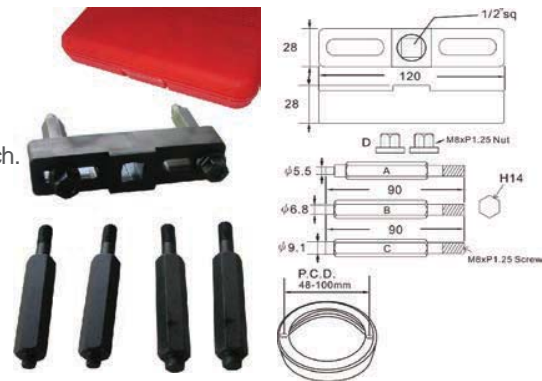

NO	Part Name	Size (Mm)	Q'ty
A	Pin (for pin-hole)	φ5.5	2
B	Pin (for pin-hole)	φ6.8	2
C	Pin (for pin-hole)	φ9.1	2
D	Nut	M8xP1.25	2
E	Main Body	L:120 * Dr. 1/2"	1

Using:  
\*Loosening/Tightening of the rear housing nuts.  
Application:  
\*used in small vehicle(over 2 tons) (For Circular Nuts)  
Function:  
\*Both sides can be adjusted  
\*Easy to center as a scale is marked on the wrench.  
\*With different size pin, the function can be various.





H.C.B-B1391

UNIVERSAL TRUCK WHEEL HUB EXTRACTOR

萬用卡車輪軸HUB拆卸器

- The bolts of this extractor are ranged from 110 mm P.C.D to 448 mm P.C.D.
- Master wheel hub extractor for Japanese trucks (Fuso, Hino...) and European trucks such as SCANIA & Sauer & BPW.
- Save time and labor!

※使用前請放開手煞車

- 本體上的螺桿距離可從110 mm P.C.D到448 mm P.C.D.
- 萬用的卡車輪軸HUB拆卸器可用於日系卡車及歐系卡車 (例如:SCANIA,Sauer 和BPW)
- 省時省力!是您最佳利器!

■ B1391-10 can use on M18 M20 M22 and 7/8"

■ B1391-11 can use on M24 and M30

VIDEO



Optional: 10, 11  
(選購配件)

Item No. / 編號	Name / 品名	Specification / 規格	Q'ty / 數量
B1391-A	Body / 本體	L500mm x H49mm x W60mm	1
B1391-A-1	Set Bolt / 螺絲	M8xP1.25	1
B1391-B	Nut / 螺帽	TM30x6 Thread	1
B1391-C	Bolt / 螺桿	TM30x6 Threadx350mm/L	1
B1391-C-1	Steel Ball / 鋼珠	Ø17.5mm	1
B1391-C-2	Central Tip / 中心尖頭	Ø23x35.8mm/L	1
B1391-D	Bolt / 螺桿	M22xP2.5&M22xP1.5x340mm/L	2
B1391-E	Nut / 螺帽	M22xP2.5(H36)	4

Item No. / 編號	Name / 品名	Specification / 規格	Q'ty / 數量
B1391-1	Thread Adaptor / 螺帽	M18xP1.5x65mm/L	2
B1391-2	Thread Adaptor / 螺帽	M20xP1.5x65mm/L	2
B1391-3	Thread Adaptor / 螺帽	M22xP1.5x65mm/L	2
B1391-4	Thread Adaptor / 螺帽	M24xP1.5x65mm/L	2
B1391-5	Thread Adaptor / 螺帽	M30xP1.5x65mm/L	2
B1391-6	Pressure Plate - Small / 小墊塊	DØ95mm x d65mm x T30mm	1
B1391-7	Pressure Plate - Large / 大墊塊	DØ110mm x d85mm x T30mm	1
B1391-8	Thread Adaptor / 螺帽	7/8" - W11	2
B1391-9	Pressure Plate / 墊塊	DØ90mmx dØ62.7x T30mm	1

H.C.B-C1391

UNIVERSAL TRUCK WHEEL HUB EXTRACTOR

萬用卡車輪軸HUB拆卸器

- Variable bolts is suitable for diameter from 110 mm P.C.D to 448 mm P.C.D.
- Master wheel hub extractor for Japanese trucks (Fuso, Hino...) and European trucks such as SCANIA & Sauer & BPW.
- Save time and labor!
- 多樣性的螺桿.可適用P.C.D 110 mm到448 mm.
- 可用在日系卡車(FUSO, HINO...)和歐系卡車上 (SCANIA, SAUER, BPW)
- 省時省力!是您最佳利器!





011

HWANG CHERNG BIN  
Specialty Tools Inc.

通用卡車修護工具

General Truck Repair Tool



General Truck  
Repair Tool

### H.C.B-A1256

### PITMAN ARM PULLER (32 mm)

大車橫拉桿球頭拔卸器 (32 mm)

- Suitable for alloy steel forged tie rod of heavy duty truck
- Can remove tie rod ends and pitman arm
- Opening size: 32 mm
- Pull travel: 64 mm
- 適用於重型卡車合金鑄造的橫拉桿。
- 可除移橫拉桿球頭和方向機搖臂。
- 開口尺寸：32 mm
- 拔出距離：64 mm



### H.C.B-A1383

### ELECTRICAL BRAKE LINING SHOE LOADER PAT. 409117

電動鉗釘機

- |  |                                 |
|--|---------------------------------|
| ■ Maximum capacity: 2.7 tons               | ■ 最大出力: 2.7噸                    |
| ■ Maximum pressure: 140 kg/cm <sup>2</sup> | ■ 最高使用壓力: 140kg/cm <sup>2</sup> |
| ■ Motor: 0.75 KW                           | ■ 馬達: 0.75KW                    |
| ■ Voltage: 220V / 1HP/60Hz                 | ■ 電壓: 220V/1HP/60Hz             |
| ■ Stroke: 100 mm                           | ■ 行程: 100 mm                    |



VIDEO



### H.C.B-A1054-2

### UNIVERSAL SEPARATOR (R2) PAT. 172921

萬用拔卸器 (R2)

12 / 17.7 / 20.5 / 1.05'

- Multi-purpose puller set for balancer, pulley & gear.
- Application: FORD, TOYOTA, LEXUS GS 300 (1999~2004)
- 可用於平衡桿、皮帶盤和齒輪拆卸
- 適用車種：FORD, TOYOTA, LEXUS GS 300 (1999~2004)



H.C.B-A1054-2 on LEXUS GS300 (1999-2004)

### H.C.B-A1054-4

### STEERING WHEEL PULLER BOLT (EXTENDED)

方向盤拔卸器螺絲 (加長型)





### H.C.B-A1287

### DAEWOO TRUCK WHEEL AXLE NUT SOCKET (Dr. 3/4", 6 POINTS, 116 mm)

大字卡車輪軸螺帽套筒 (Dr. 3/4", 6角, 116 mm)

- To remove / replace the wheel axle nut of DAEWOO.
- Size: Dr. 3/4", 6 points, 116 mm.
- 可移除/更換大字卡車的輪軸螺帽。
- 尺寸: Dr. 3/4", 6角, 116 mm



### H.C.B-A2018-27

### HYUNDAI PORTER / KIA MOTOR TRUCK OIL FILTER WRENCH (Dr. 1/2", 15 POINTS, 91.7 mm)

HYUNDAI PORTER / KIA MOTOR卡車機油芯扳手 (Dr. 1/2", 15角, 91.7 mm)

- Oil filter genuine no. : 26300-42040 26300-42030· 26300-42060
- Application: HYUNDAI PORTER TRUCK · KIA Motors
- Size: Dr. 1/2", 15 Points, 91.7 mm
- 機油芯料號: 26300-42040 26300-42030 26300-42060
- 適用車種: HYUNDAI PORTER TRUCK· KIA Motors
- 尺寸: Dr. 1/2", 15角, 91.7 mm



### H.C.B-A2013

### TRANSMISSION FLOOR JACK (1 TON)

臥式變速箱千斤頂 (1噸)

1 / 60 / 63.8 / 3.81'

- Designed ideally for removal and installation of automobile and light truck transmission or differential.
- Universal saddle, brackets and chain sling are fully adjustable to accommodate transmission, clutches and differential in varying size.
- Safety overload system and safety by-pass system prevent from damaging cylinder.
- Flash chromed ram inhibits rust from entering the hydraulic system.
- Four swivel caster wheels allow for easy positioning.
- Low frame passes undercarriage obstacles easily.
- Sensitive release valve helps to load lower.
- 可用來移除和安裝汽車及輕型卡車的變速箱或差速器的理想工具。
- 萬用的托架、支撐座和吊鏈可調整，用於各種尺寸的變速箱、離合器和差速器。
- 防超載、防傾倒系統，可避免損壞油壓缸。
- 亮面的鍍鉻油壓缸，可以預防夾帶灰塵進入油壓系統中。
- 四個可轉動的腳輪，方便推動。
- 低底座可輕易地通過汽車底盤下的障礙物。
- 感應式洩壓閥可讓載重後的千斤頂放得更低。







**H.C.B-F1168**
**UNIVERSAL BALL JOINT SERVICE KIT PAT M.333280**

專利型萬象十字接頭拔卸器

- Special design for bolt, if the bolt is broken and you only need to replace the bolt of c-clamp, don't need to change the whole c-clamp set.
- The C-clamp was forged, its material is SCM440 and hardness is HRC 38°-42°
- On car maintenance
- It contains heavy-duty C frame press, receiver tubes, and adapters that both install and remove pins.
- This tool set is designed for using on most cars and light trucks that have press-fit type ball joints. It will help the user remove and install ball joints without the need to remove the control arm from the vehicle.

NOTE: Some cars and light trucks may have the upper ball joint spot-welded to the control arm. The weld must be cut before attempting to remove the ball joint.

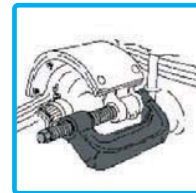
- C型內有特殊設計，當螺絲斷裂，只需更換螺絲，而不需更換整個C型。
- 此C型為鍛造，材質是SCM440，硬度為 HRC 38°-42°
- 可在車上直接做維修動作
- 此工具包含C型，和拆卸/安裝管
- 此工具組設計可使用在有大部分的小車和輕型卡車。  
不用將控制臂從引擎拆下，技師就可直接拆卸/安裝球接頭。



Brake Anchor Pin  
Extraction and Installation

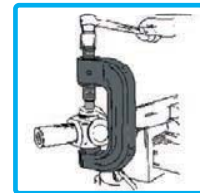

"U" Joint Extracgion  
and Installation

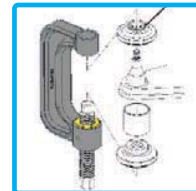

Removal

Patented design O-ring can be fixed in top, to prevent the tool from falling

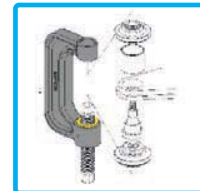

Installation

Patented design O-ring can be fixed in top, to prevent the tool from falling

**H.C.B-A2019**
**3 TONS FOUR WHEELS HYDRAULIC FLOOR JACK**

3 噸油壓四輪千斤頂

**1 / 69 / 74 / 4.9'**

- Features:
  1. Ideally suitable for all automotive, agriculture and light truck repair facilities.
  2. Mobile "T" handle and two mobile foot pedals can speed up loading.
  3. "T" handle can be locked in the position of three specific angles to lower load and easy maneuvering.
  4. Extra long chassis can reach any position under the vehicle.
  5. Hydraulic power unit with dust seals to prevent oil contamination.
  6. Large and heavy-duty swivel caster wheels provide easy maneuvering and positioning of jack.
- Capacity: 3 tons

■ 產品特色：

1. 適用於所有的汽車、農機和輕型卡車的維修。
2. 活動式的T型把手和兩個活動式踏板，可加速裝載。
3. T型把手可以固定在三個特殊的角度，用來放低重心、方便移動。
4. 加長的底座可以深入車底。
5. 油壓系統加防塵油封，可預防油污。
6. 大型耐重的旋轉輪，可防止傾倒和定位千斤頂。

■ 載重：3噸

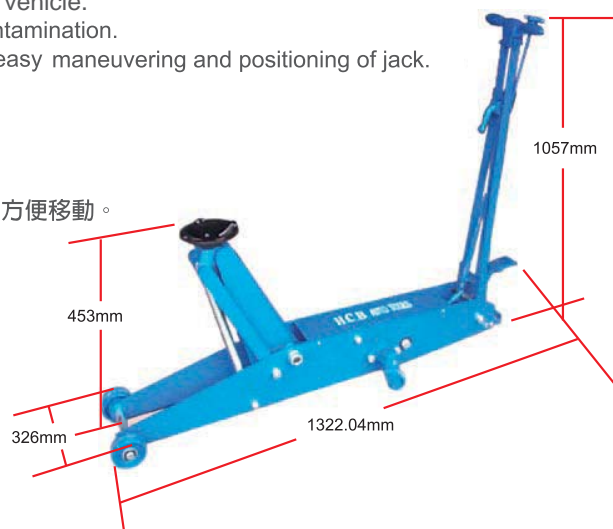

## H.C.B-A2101

UNIVERSAL ADJUSTABLE WHEEL BEARING  
LOCK NUT WRENCH

後軸螺帽拆卸器 (萬用型) 10 / 25 / 26 / 1.71'

- Adjustable jaws to fit all hexagon & octagon wheel bearing lock nuts.
- Contains three sets of pins, is applicable to any size nut.
- Specification:  
6PT lock nuts: 1-3/4" to 5-3/4" (49~135 mm)  
8PT lock nuts: 1-3/4" to 5-5/9" (49~143 mm)  
Pin diameters: 1/4" (6 mm), 5/16" (8 mm) and 3/8" (10 mm)

- 可調整式拔取爪可適用於所有六角和八角的輪軸培林固定螺帽。
- 本組工具配備有三組插銷，可適用於任何尺寸螺帽。
- 規格：  
6角固定螺帽：1-3/4" to 5-3/4" (49~135 mm)  
8角固定螺帽：1-3/4" to 5-5/9" (49~143 mm)  
插銷尺寸：1/4" (6 mm), 5/16" (8 mm) and 3/8" (10 mm)



## H.C.B-A2102

## HYDRAULIC WHEEL DOLLY

大車輪胎搬運車

- Easy to remove / install / move tires.
- Hydraulic lifting.
- Rolling carriage can assist tire to rotate to the right position.
- Stand firm by four wheels. Also help to lifting steadily.
- Light frame and two swivel casters. make it easy to move.
- Multi-functional tool.
- Maximum capacity of carriage: 52" tire.
- Maximum capacity of hydraulic jack: 2 tons.
- 可拆卸/安裝/搬運輪胎。
- 油壓式升高裝置。
- 滾動式承載架可協助輪胎轉動至正確位置。
- 四個腳輪可讓搬運車站得更穩、升高時也更穩定。
- 輕量化的本體結構和兩個可旋轉的腳輪，讓移動更方便。
- 多功能的工具。
- 最大承載尺寸：52"輪胎
- 油壓缸：2噸

VIDEO



Capacity (KG/LBS)	Lift Range (mm/inch)	Length of Lifting Arms (mm/inch)	Overall Length (mm/inch)	Overall Width (mm/inch)	Overall Height (mm/inch)	Package (W/Case)
500/1200	115-290 4-1/2"~11-2/5"	570 22-2/5"	810 31-9/10"	890 35"	800 31-1/2"	94KG/99KG /17.5'

## H.C.B-B2102

NEW

## HYDRAULIC WHEEL DOLLY

大車輪胎搬運車

FEATURES:

- Equipped with foot-operated hydraulic jack which makes it more convenient to operate when installing wheels.
- Heavy-duty chain can secure the wheels.
- Tubular lifting arms which are adjustable can easily fit and carry the middle and large size tires.
- Rear casters and front wheels help to move this dolly easily with good maneuverability.
- Adjustable rear casters with 3-1/4" travel.
- Foot pedal can be folded up for storage and prevent the risk of injury.
- Capacity: 600 Kg
- N.W.: 103 Kgs, G.W.: 113 Kgs, CUFT.: 15.7'

特色:

- 此輪胎搬運車配有腳踏型油壓千斤頂，讓安裝輪胎時可以更方便的操作千斤頂。
- 配有高負重鐵鍊，可以固定輪胎，以防掉落。
- 鋼管型可調式舉升臂可以對應、承載各種中、大型輪胎。
- 後方腳輪及前方固定輪可協助移動、操控此搬運車。
- 可調式後方腳輪，具3-1/4"的可調行程。
- 腳踏板可以摺疊以便收納及防止有人碰觸、受傷。
- 最大負重: 600 Kg ■ 淨重: 103 Kgs、毛重: 113 Kgs、材積: 15.7'







**H.C.B-A1015**
**BLIND HOLE BEARING PULLER**

隱蔽型培林拔卸組

**5 / 17.2 / 18 / 1.64'**

- One slide hammer assemble & 4 clamps.
- Attachments: ① 3/8" to 1/2" (10-14 mm)  
 ② 9/16" to 11/16" (15-19 mm)  
 ③ 5/8" to 1" (18-25 mm)  
 ④ 1" to 1-1/4" (25-32 mm)  
 ID bearings' pulling.
- Open clamps by turning handle clockwise to grab the bearing for pulling out evenly without damaging the parts.

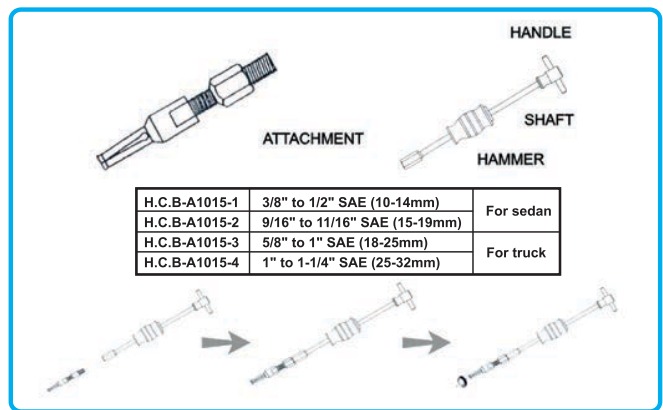
- 本組工具包含一支滑鎚和四支螺桿拔取爪。
- 螺桿拔取爪尺寸：
  1. 3/8" - 1/2" (10-14 mm)
  2. 9/16" - 11/16" (15-19 mm)
  3. 5/8" - 1" (18-25 mm)
  4. 1" - 1-1/4" (25-32 mm)
- 順時針方向轉動手把、張開螺桿拔取爪直到貼合培林的內側，以拔出培林。不會損壞相關零件。

**H.C.B-B2115**
**BLIND HOLE BEARING PULLER**

隱蔽型培林拔卸組

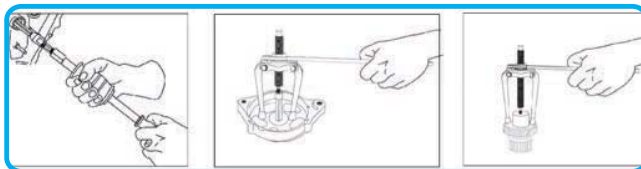

- Applicable to automobiles, motorcycles, and machine repairing. It is convenient and easy to use.
- Both slide hammer-type bearing puller or two-leg universal pullers are capable to remove the bearings.
- It is the best tool used on manual transmission blind hole flywheel bearing. For example: TOYOTA, FORD...etc.
- H.C.B-B2115-9-3 can be used to remove the log pin installed on motorcycles.
- 適用於汽車，摩托車和機械的維修。方便好操作。
- 包含有滑鎚式和兩爪式的培林拔卸器。
- 拔取變速箱飛輪隱蔽型培林的利器。適用車種繁多，例如：TOYOTA, FORD...等。
- H.C.B-B2115-9-3可以用於維修摩托車。

REF		RANGE
H.C.B-B2115-1		min A max 8mm-11mm
H.C.B-B2115-2		min A max 12mm-17mm
H.C.B-B2115-3		min A max 18mm-23mm
H.C.B-B2115-4		min A max 24mm-29mm
H.C.B-B2115-5		min A max 30mm-34mm
H.C.B-B2115-10		min A max 34mm-38mm
H.C.B-B2115-11		min A max 39mm-43mm
H.C.B-B2115-12		min A max 44mm-48mm
H.C.B-B2115-13		min A max 49mm-53mm
H.C.B-B2115-14		min A max 54mm-58mm
H.C.B-B2115-9-1		A size M10*1.5P B size
H.C.B-B2115-9-2		A size M10*1.5P B size M8*1.25P
H.C.B-B2115-9-3		A size M10*1.5P B size M6*1.0P





通用卡車修護工具

General Truck Repair Tool



011

HWANG CHERNG BIN  
Specialty Tools Inc.



## H.C.B-A1655

**NEW**

### UNIVERSAL BEARING EXTRACTOR

萬用培林拆卸器

- For extracting inner bearings, bearing outer rings and bushings.
- Mechanical pressure screw.
- Milled thread treated with special coating.
- Strong design, high performance and long service life.
- Safety label to ensure protection of intellectual property.
- Self-healing corrosion protection for galvanized parts.

- 此拆卸器適用於拔除內部培林、培林外圍環及鐵套。
- 機械式壓力螺絲。
- 具特殊塗層螺牙。
- 完美的設計提供高效能及長久的使用壽命。
- 拆卸器上貼有安全貼標提供正確的安全知識。
- 具鍍鎳的零件可防止鏽蝕。



No.	Bearing Size		Screw Size		Screw Length		Segment	kg
	mm	inch	mm	inch	mm	inch		
A1655-01	6 - 10	15/64 - 25/64	14	9/16	73	2 7/8	2	0.12
A1655-02	8 - 12	5/16 - 15/32	14	9/16	73	2 7/8	2	0.115
A1655-03	10 - 14	25/64 - 9/16	14	9/16	73	2 7/8	2	0.115
A1655-04	12 - 16	15/32 - 5/8	25	1	72	2 27/32	2	0.16
A1655-05	14 - 19	9/16 - 3/4	27	1 1/16	72	2 27/32	2	0.12
A1655-06	18 - 23	23/32 - 29/32	35	1 3/8	89	3 1/2	2	0.225
A1655-07	20 - 30	25/32 - 1 3/16	40	1 9/16	92	3 5/8	2	0.235
A1655-08	28 - 40	1 7/64 - 1 9/16	23	29/32	101	3 31/32	2	0.395
A1655-09	35 - 46	1 3/8 - 1 13/16	50	1 31/32	113	4 7/16	2	0.68
A1655-10	45 - 58	1 25/32 - 2 9/32	85	3 11/32	135	5 5/16	2	1.23

## H.C.B-A2045

### 1.5 TONS TRUCK TRANSMISSION JACK

1.5 噸卡車變速箱千斤頂

1 / 130 / 150 / 10.5'

- The best tool for removing / installing transmission or differential of auto and light trucks.
- This set contains adjustable saddle brackets and chain, and is suitable for to every size of transmission clutches and differential .
- Safe overload and bypass system prevents cylinder from damaging.
- Rust-proof with flashing chromed ram inside the hydraulic system. 360° rotary handle. Easy to use.
- Four swivel caster wheels are easy to move under the vehicles.
- Releasing the valve to lower this tool.
- Capacity: 1.5 tons



- 移除和安裝汽車及輕型卡車的變速箱或差速器的絕佳工具。
- 本工具配備有可調式托架、支撐座和吊鏈，可用於各種尺寸的變速箱、離合器和差速器。
- 防超載、防傾倒系統，可避免損壞油壓缸。
- 防塵的亮面鍍鉻油壓缸，可以預防夾帶灰塵進入油壓系統中。
- 四個可轉動的腳輪，方便推動。
- 放開洩壓閥可放低千斤頂。
- 載重：1.5噸



General Truck Repair Tool

**H.C.B-A2165**
**HYDRAULIC BEARING PULLER (8 TONS)**

油壓式培林拔輪器 (8噸)

**H.C.B-B2165**
**HYDRAULIC BEARING PULLER (8 TONS)**

油壓式培林拔輪器 (8噸)

**H.C.B-C2165**
**HYDRAULIC BEARING PULLER (12 TONS)**

油壓式培林拔輪器 (12噸)

**H.C.B-D2165**
**HYDRAULIC BEARING PULLER (4 TONS)**

油壓式培林拔卸器 (4噸)

**H.C.B-A2165**

**H.C.B-B2165**

**H.C.B-C2165**

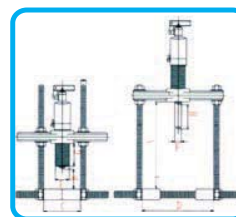
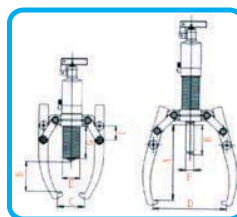
**H.C.B-D2165**

**HYDRAULIC BEARING PULLER**  
 油壓式培林拔輪器

Item No.	CAPACITY	Reach(mm)		Spread(mm)		Stroke(mm)	Pump Tip(mm)			Jaw Tip(mm)				Weight (Kg)
		A	B	C	D		H	E	F	G	A	B	C	
A2165	8 TONS	270	-	95	220	85	50	25	122	-	-	-	-	14.3
B2165	8 TONS	229	57	100	350	85	50	25	122	11	10	25	51	8.2
C2165	12 TONS	381	-	120	290	85	60	28	118	-	-	-	-	18.0
D2165	4 TONS	250		55	110	60	42	22	84					7.6

- Four stages of foldable & removable handle saves the labor during operation.
- 360° rotary socket.
- Integrated hydraulic pump which has puller with safely valve.
- Heat treated & chrome plated hydraulic cylinder rod provides stronger pulling force.
- Easily release valve.
- Spring loaded central nut for easy job (replaceable).
- 2/3 jaws combination puller cross head with manganous-phosphate plated for rust proof and durability.
- Heat treated forged alloy steel cross bolts & jaws with manganous-phosphate plated for rust proof and long life service.
- 四段式的折疊、可移除的手把，讓操作更省力。
- 360° 旋轉式套筒。
- 包含一體成型的油壓組和附有安全閥門的拔取器。
- 熱處理鍍鉻油壓桿，提供更強的拔取力。
- 方便操作的閥門。
- 可更換式彈簧支撐中心螺帽，方便操作。
- 鍍磷酸錳的拔取爪，可防塵、更耐用。
- 熱處理鍍磷酸錳螺絲，可防塵、更耐用。



**H.C.B-B2126**

**20 TONS AIR HYDRAULIC BOTTLE JACK**

20 噸氣動油壓千斤頂

**H.C.B-B2127**

**30 TONS AIR HYDRAULIC BOTTLE JACK**

30 噸氣動油壓千斤頂



**H.C.B-B2126**



**H.C.B-B2127**

Product number	Cylinder Capacity (Ton)	Stroke (mm)	Coll. Height A(mm)	Ext. Height B(mm)	Plunger Dia J(mm)	Base Dimensions LxM(mm)	Auxiliary Height (mm)	Weight (kg)	Air pressure Range (Kgf/cm)
H.C.B-B2126	20	106	204	310	55	125x190	17,43,68	12.6	8-12
H.C.B-B2127	30	145	245	390	75	225x150	10,45,80,	22.7	8-12

- The carbon steel base by automatic weld makes stable quality. ■ 高品質的中碳鋼、焊接底座。
- The self-return functions of flashing chrome plunger can extend life and resist corrosion. ■ 鍍鉻亮面、自動收回式油壓桿，可延長使用期、防鏽。
- Design of air pump makes operation highly efficient. ■ 可連接氣壓幫浦使用，提高效率。
- For all model. ■ 通用型。

**H.C.B-A2146**

**PNEUMATIC GREASE PUMP (20 L)**

氣動黃油機 (20升)



- Pneumatic Grease Pump uses air as power to suck grease into lubrication points. It is suitable for using with machines, automobiles and vessels ... etc. It is a very useful tool for lubrication and maintenance.
- 分離式幫浦，利用壓縮空氣驅動抽取流質液體，幫浦為兩個獨立循環系統，空氣水份不致接觸油質，適用於各種機械、車輛、飛機、輪船等，為保養潤滑時強勁注入黃油的利器。

Model 型號	Capacity 容量	Air Input Pressure 容氣輸入壓力	Pressure Ratio 壓力比	Grease Output Pressure 黃油輸出壓力	Deliver Rate 輸出量	Hose Length 油管長度	N.W. 淨重	G.W. 毛重	CUFT 材積
H.C.B-A2146	20L	4~9Kg/cm <sup>2</sup>	45:1	180~405Kg/cm <sup>2</sup>	30cc/sec	10 ft	20.9Kgs	23.4Kgs	6.2'





011

HWANG CHERNG BIN  
Specialty Tools Inc.

通用卡車修護工具

General Truck Repair Tool



General Truck  
Repair Tool

## H.C.B-A2160

## WASTE OIL DRAINER (80L)

廢油桶 (80升)

- Waste oil mobile reservoirs are used for motor and gear oil collection .
- Drainers can be used under vehicle lifts or inside lubrication pit.
- Large handle for easy maneuverability.
- Two brake wheels (φ3" ) and two casters (φ3" )
- Extra large and adjustable drain bowl can collect waste oil conveniently and safely

- 可用於承接機油箱和齒輪箱的廢油。
- 廢油盤可以放置在堆高機下方或油箱內。
- 加長把手可方便操作。
- 配備有兩個剎車腳輪、兩個轉向腳輪。
- 加大、可調整式的廢油盤，可方便、安全地承接廢油。

### Specification

Model	H.C.B - A2160
Dimension	470x560x1140~1580 mm
Capacity	80 L
Weight	36 kgs
Oil Draining	Compressed Aiv 100~120 PSI
Power	Air Pressure



### Accessory:



Oil Drain Pan / 550 mm



Oil Drain Pan / 530 mm



Collection Bowl / 380 mm



Pre-Spray Net

## H.C.B-B2160

NEW

## 50 L WASTE OIL DRAINER (MANUAL)

手動升降式佇油機(50升)

- Composite lid and drum with 50 liters reservoir and drain pan telescopic post
- Gravity drain using tap on rear of unit. Includes visible 'Full Drum' device.
- Includes large diameter drain pan insert and heavy duty mesh for draining oil filters.
- Manual operation
- Dimension: 550x550x900-1070 m/m
- Capacity: 50 L
- Weight: 12 kg

- 配有複合式的蓋子可儲存50公升的儲油桶
- 內含大尺寸的排水盤和強大的排水濾油系統
- 手動操作
- 尺寸:550x 550x 900 mm
- 容量:50公升
- 重量:12KG





通用卡車修護工具

General Truck Repair Tool



011

HWANG CHERNG BIN  
Specialty Tools Inc.



## H.C.B-A2203

## PNEUMATIC FLUID EXTRACTOR (8.5 L)

氣動抽油機 (8.5升)

4 / 6 / 10 / 3.8'

- Can extract car engine oil. Capacity 8.5 L.
- Pneumatic extractor, non-sparking making.
- Only need one person to operate.
- 1 meter silicon hose with universal rubber adapters can fit most of brake.
- Special fixing valve and safety cup are for automatic cut-off extracting.

- 可抽取汽車機油，最大容積8.5公升。
- 氣動式抽取，不會產生火花。
- 只需一人即可操作。
- 1公尺長矽膠管配上萬用橡膠接頭，可用於大部份的車輛。
- 特殊的固定式閥門和安全杯，可自動中斷抽油動作。

ADAPTER (OPITION) :  
■ NITTO ■ MILTON ■ ORION



### SPECIFICATIONS:

Air inlet	1/4"
Avg. Air cons	2 CFM
Working pressure	40 ~ 170 PSI
Temperature range	-19.4°C ~ 60°C
Max. Capacity	8500 c.c.

## H.C.B-A2204

## PNEUMATIC OIL & LIQUID DISPENSER (6000 c.c.)

吸排兩用液體分裝機 (6000 c.c.)

6 / 16 / 17 / 4.7'

- Equipped with the safety valve helps to stop air pressure automatically when the pressure reaches the pre-setting (43psi h(3kg/cm<sup>2</sup>))
- Provide with pressure gauge makes read and control the air pressure in the tank more easily
- Application: BENZ 722.9
- 有安全閥可預設自動停止的壓力(43 psi (3 kg/cm<sup>2</sup>))。
- 配備有壓力錶，方便讀取和控制桶內的壓力。
- 適用車種：BENZ 722.9

### SPECIFICATIONS:

Air inlet	1/4"
Avg. Air cons	2 CFM
Temperature range	-19.4°C ~ 60°C
Max. Capacity	6000 c.c.

ADAPTER (OPITION) :  
■ NITTO ■ MILTON ■ ORION





## H.C.B-A2205

## BASIC BRAKE OIL EXTRACTOR (2000 c.c.)

專業剎車油吸取機(2000 c.c.)

ADAPTER (OPITION):  
■ NITTO ■ MILTON ■ ORION

12 / 15 / 16 / 6'

- Economical - fast and easy, reduces labor costs.
- Versatile - handles most standard and ABS brake system.
- Clean - collects old brake fluid without spillage.
- Quiet - integrated silencer for a quiet working environment.
- Silicon - suction assemblies with universal rubber fitting.
- 經濟－快速、簡便，可節省人力成本
- 用途多－可用於大部份標準和ABS煞車系統
- 乾淨－收集廢油、不用擔心溢漏
- 靜音－一體成型式消音器，提供安靜的工作環境
- 配備有矽膠抽取器和萬用橡膠接頭

■ SPECIFICATIONS:

Air inlet	1/4"
Avg. Air cons	2 CFM
Working pressure	40 ~ 170 PSI
Temperature range	-19.4°C ~ 60°C
Max. Capacity	2000 c.c.



## H.C.B-A2206

## BRAKE OIL FILLER (1000 c.c.)

剎車油補充油瓶(1000 c.c.)

12 / 7 / 8 / 1.8'

- To fill brake oil easily
- Capacity : 1000 c.c.
- 方便灌注剎車油
- 容量 : 1000 c.c.



ADAPTER (OPITION):  
■ NITTO ■ MILTON ■ ORION

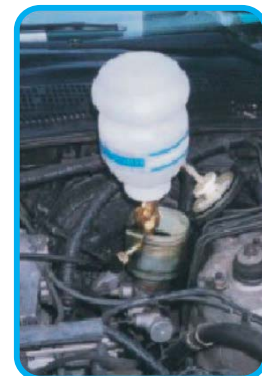
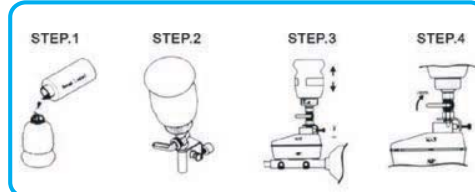





### H.C.B-A1065

### WAGON SUPPORTER

貨車專用安全頂架 (配合平板頂車機使用)



### H.C.B-A2147

### GREASE FILLER FOR PAIL (20 L)

鋁合金手壓式培林注油機 (20升)



放入培林

注油完成



強力型黃油壓力板



型號 (Model)	H.C.B-A2147
尺寸 (Dimension)	340 x 330 x 570 mm
材質 (Material)	鋁合金(Aluminium alloy)
重量 (Weight)	8.1 kgs
適用範圍 (Bearing Diameter)	120 ~ 170 mm
適用車種 (Application)	中型卡車 (medium truck)

### H.C.B-A2148

### TRACK BEARING PACKER (FOR TRUCK)

鋁合金氣壓式培林注油機



型號 (Model)	H.C.B-A2148
尺寸 (Dimension)	240 x 240 x 200 mm
材質 (Material)	鋁合金(Aluminium alloy)
重量 (Weight)	6.8 kgs
適用範圍 (Bearing Diameter)	150 ~ 200 mm
直徑 (φ)	200 mm
適用車種 (Application)	大型卡車 (Freight vehicle)





## H.C.B-A2157

## TRUCK JACK STAND 15,000 LBS

卡車千斤頂 15,000磅

- Spring loaded caster for easy positioning and portability.
- 彈簧支撐腳輪可協助定位和移動。

Item	Part No.	Description	QTY.
1	H.C.B-A2157-1	Main Tube	1
2	H.C.B-A2157-2	Removal Tube	1
3	H.C.B-A2157-3	Leg	3
4	H.C.B-A2157-4	Link	3
5	H.C.B-A2157-5	Spring Loaded	3
6	H.C.B-A2157-6	Saddle	1
7	H.C.B-A2157-7	Screw	3
8	H.C.B-A2157-8	Nut	9
9	H.C.B-A2157-9	Screw	3
10	H.C.B-A2157-10	Screw	3
11	H.C.B-A2157-11	Load Pin	1
12	H.C.B-A2157-12	Grip	9
13	H.C.B-A2157-13	Set Screw	2

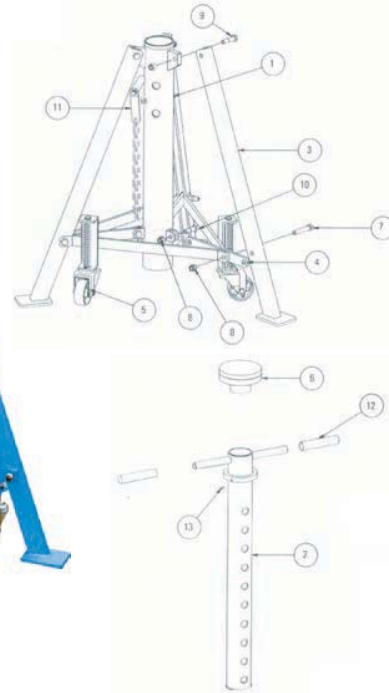

Specification	Width	Length	Height	Stroke	N.W.	G.W.
Size	803.3 mm	698.5 mm	870 mm	540 mm	45 kgs	47 kgs

## H.C.B-A2158

## TRUCK JACK STAND 15,000 LBS

卡車千斤頂 15,000磅

- Spring loaded caster for easy positioning and portability.
- 彈簧支撐腳輪可協助定位和移動。

Item	Part No.	Description	QTY.
1	H.C.B-A2158-1	Main Tube	1
2	H.C.B-A2158-2	Removal Tube	1
3	H.C.B-A2158-3	Set Screw	2
4	H.C.B-A2158-4	Spring	1
5	H.C.B-A2158-5	Load Pin	1
6	H.C.B-A2158-6	Leg	3
7	H.C.B-A2158-7	Link	3
8	H.C.B-A2158-8	Spring Loaded	3
9	H.C.B-A2158-9	Screw	3
10	H.C.B-A2158-10	Screw	3
11	H.C.B-A2158-11	Screw	3
12	H.C.B-A2158-12	Anti-Nut	9
13	H.C.B-A2158-13	Grip	2
14	H.C.B-A2158-14	Swivel Adapter	1
15	H.C.B-A2158-15	Set Screw	1
16	H.C.B-A2158-16	Spindle Assy	1
17	H.C.B-A2158-17	Saddle	1

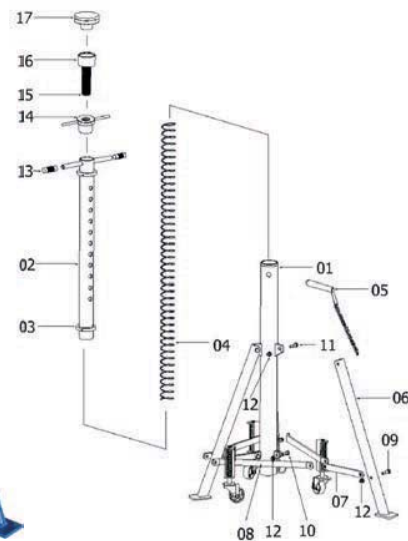

Specification	Width	Length	Height	Stroke	N.W.	G.W.
Size	803 mm	698.5 mm	Max:2096.5 mm/ Min:1426.5 mm	670 mm	58 kgs	61 kgs

H.C.B-B2158

TRUCK JACK STAND 33,000 LBS

卡車千斤頂33,000磅



Specification	Width	Length	Height	Stroke	N.W.
Size	948.5 mm	821.5 mm	Max: 2089 mm Min:1389 mm	700 mm	98 kgs

H.C.B-A2226

JACK STAND (18")

貨車頂車架(18")

H.C.B-B2226

JACK STAND (24")

貨車頂車架(24")

H.C.B-C2226

JACK STAND (28")

貨車頂車架(28")

- To adjust the height by turning nut and stud.
- 以螺帽和螺柱來調整高度。



Item No. / 編號	capacity/ 承載重量(噸)	Height / 高度 (mm)	Base / 底座 (mm)	Qty' / Carton 數量/箱	N.W. / 淨重 (Kg)	G..W. / 毛重 (Kg)	Cuft / 材數
A2226	12	456~710	φ 467	1	18.5	19.5	0.7
B2226	12	614~868	φ 590	1	21	22	1
C2226	12	710~1065	φ 670	1	25	26	1





011

HWANG CHERNG BIN  
Specialty Tools Inc.

通用卡車修護工具  
General Truck Repair Tool



General Truck  
Repair Tool

### H.C.B-A2009

### CLUTCH ALIGNMENT TOOL (IRON)

離合器對孔校正器(鐵)

- Align single disc clutches on most of vehicles, light trucks & tractors. Properly aligns clutch plate by fitting cone into bushing or bearing.
- Size of 8 adaptors: from 0.465"(11 mm) to 0.980" (24.9 mm)
- N.W.: 0.7 kgs
- 可校正大部份汽車、輕型卡車和拖車上的單碟離合器。將圓錐伸入導向鐵套或培林中，即可校正離合器盤。
- 8款接頭尺寸：0.465"-0.98" (11mm-24.9mm)
- 淨重：0.7公斤



### H.C.B-A2021

### SOCKET TOOL KIT (34 PCS)

星型中空,E型綜合套筒組(34 PCS)

- Content:
- 5 pcs 1/4" Star-E socket: E4, E5, E6, E7, E8
- 4 pcs 3/8" Star-E socket: E10, E12, E14, E16
- 2 pcs 1/2" Star-E socket: E18, E20
- 2 pcs 1/2" TORX bit socket: T55, T60
- 4 pcs 3/8" TORX bit socket: T40, T45, T47, T50
- 1 pc 1/2" TAMPER. TORX bit socket: T55
- 3 pcs 3/8" TAMPER. TORX bit socket: T40, T45, T50
- 7 pcs 1/4" TORX bit socket: T8, T10, T15, T20, T25, T27, T30
- 6 pcs 1/4" TAMPER. TORX bit socket: T10, T15, T20, T25, T27, T30
- N.W.: 1.5 KGS



Star-E



TORX bit



TAMPER. TORX



### H.C.B-A2022

### 18 PCS IMPACT HEXAGON & TX-STAR WRENCH KIT

六角,星型凸套筒組(18 PCS)

- Specification / 規格:
- Hexagon / 六角: H5, H6, H7, H8, H10, H12, H14, H17
- TX-Star / 星形: T30, T40, T45, T50, T55, T60, T70
- Dr. 1/2 x 125mm extension bar / 延長桿
- Dr. 1/2 x 250mm sliding T-handle / T形扳手
- Dr. 1/2 ratchet handle / 棘輪扳手
- Applicable: most of cars / 適用大部份車輛
- N.W.: 3.3 kgs / 淨重: 3.3公斤



TX-STAR



Hexagon





通用卡車修護工具

General Truck Repair Tool



011

HWANG CHERNG BIN  
Specialty Tools Inc.



## H.C.B-A2086

160 PCS COMPREHENSIVE TOOL KIT

160 PCS 專業級套筒組

2 / 23.5 / 24.5 / 1.42'

### ■ Specification

13-1/4" socket:  
3.5,4,4.5,5,5.5,6,7,8,9,10,11,12,13 mm  
5-1/4" deep socket:5.5,6,7,8,9 mm  
1-1/4" ratchet handle  
1-1/4" spanner handle  
1-1/4" bit adapter  
2-1/4" extension bar 2" & 4"  
1-1/4" sliding T-Bar  
1-1/4" universal joint  
18-1/4" bit socket  
8-3/8" socket: 10,13,14,15,16,17,18,19 mm  
6-3/8" deep socket: 10,11,12,13,14,15 mm  
3-3/8" spark plug: 16,18,21 mm  
8-3/8" star socket:8,10,11,12,14,16,18,20 mm  
1-coupler 3/8"×5/16"  
1-3/8" ratchet handle  
1-TM head 3/8" F×1/2" m  
1-Adapter 3/8" F×1/4" m  
2-3/8" extension bar 3' & 10"  
1-3/8" universal joint  
1-3/8" bit adapter  
10-1/2" socket: 17,19,20,21,22,24,27,30,32,34 mm



4-1/2" power socket: 17,19,21,23 mm  
3-1/2" deep socket: 17,19,22 mm  
1-Coupler 1/2"×5/16"  
1-1/2" ratchet handle  
2-1/2" extension bar 5" & 10"  
1-TM head 1/2" F×3/8" m  
1-Adapter 1/2" F×3/8" m  
1-1/2" universal joint  
34-5/16" bit  
3-Gear wrench: 8×10, 13×15, 17×19 mm  
12-Combination wrench:  
8,10,11,12,13,14,15,16,17,18,19,22 mm  
11-Hexkey: 1.5,2,2.5,3,4,5,6,7,8,10 mm

## H.C.B-A2145

94 PCS (Dr. 1/4" & 1/2") TOOL KIT

94 PCS (Dr.1/4" & 1/2") 套筒組

### ■ Contents:

13 pcs 1/4" Socket: 4/4.5/5/5.5/6/7/8/9/10/11/12/13/14mm  
18 pcs 1/2" Socket: 10/11/12/13/14/15/16/17/18/19/20/21/  
22/23/24/27/30/32 mm  
5 pcs 1/2" Deep Socket: 14/15/17/19mm  
8 pcs 1/4" Deep Socket: 6/7/8/9/10/11/12/13 mm  
1 pc 1/2" Ratchet handle  
1 pc 1/4" Ratchet handle  
2 pcs 1/4" Extension Bar 50 & 100 mm  
2 pcs 1/2" Extension Bar 125 & 250 mm  
1 pc 1/4" Sliding T handle  
1 pc 1/2" Universal joint  
2 pcs 1/2" Spark Plug Socket: 16 & 21 mm  
1 pc 1/4" Spanner handle  
1 pc 1/4" Universal joint  
1 pc T-M head  
1 pc Coupler  
3 pcs Hex. key: 1.5/2/2.5 mm  
1 pc 1/4" Flexible Extension Bar 150 mm  
17 pcs 1/4" Bit-Sockets: (-) 4/5.5/7,(+)#1/2,(\*)#1/2,  
(H)3/4/5/6,(T)8/10/15/20/25/30  
15-Bits: (-)8/10/12,(+)#3/4,(\*)3/4,(H)8/10/12/14,  
(T)40/45/50/55





011

HWANG CHERNG BIN  
Specialty Tools Inc.

通用卡車修護工具  
General Truck Repair Tool



General Truck  
Repair Tool

### H.C.B-A2166 16 PCS (Dr. 3/4" & 1" ) SQ. DRIVE INSERT BIT SOCKET KIT

16 PCS 套筒組 (Dr. 3/4" & 1")

3 / 19.8 / 20.3 / 1.03'

- ★ 5-107mm (L.) , Tx-Star : T60, T70, T80, T90, T100
- ● 4-107mm (L.) , Hexagon : 17, 19, 22, 24 mm
- ⊛ 4-107mm (L.) , Star-E : E18, E20, E22, E24
- ○ 1-3/4" Sq. Drive, Hexagon Socket : 22 mm
- ○ 1-1" Sq. Drive, Hexagon Socket : 22 mm
- ● 1-Hexagon L-Key : 4 mm



### H.C.B-A2168 9 PCS STAR-E SOCKET KIT (E10/E11/E12/E14/E16/E18/E20/E22/E24)

9 PCS E型套筒組  
(E10/E11/E12/E14/E16/E18/E20/E22/E24)

- Dr. 1/2" E-Socket: E10,E11,E12,E14,E16,E18, E20,E22,E24



### H.C.B-A2209 DIESEL INJECTOR SEAT CUTTER KIT

柴油噴油嘴座清除器

20 / 19.2 / 19.7 / 2'

- To clean and re-cutting the injector seat of modern common rail diesel engines.
- 可清除柴油引擎的噴油嘴座



■ Specification and Application:

ITEM No.	Specification / 規格	Q'ty	Applicable / 適用車種
1	19mm x 17mm Flat	1 pc	Benz CRD
2	17mm x 17mm Flat	1 pc	BMW, Peugeot, Citroen and Renault
3	15mm x 19mm Flat	1 pc	For most of autos and trucks
4	21mm x 17mm Angled	1 pc	Fiat and Iveco
5	T Handle	1 pc	
6	Pilot Post	1 pc	







通用卡車修護工具

General Truck Repair Tool



011

HWANG CHERNG BIN  
Specialty Tools Inc.



## H.C.B-A2107

### EXTRA LONG OFFSET BOX WRENCH KIT (8 PCS)

加長型梅花扳手組 (8 PCS)



Item	SPEC. (mm) 規格	Length 長度	Item	SPEC. (mm) 規格	Length 長度
A2107-1	8 x10	235	A2107-5	14 x17	370
A2107-2	10 x12	295	A2107-6	16 x18	405
A2107-3	12 x14	330	A2107-7	17 x19	405
A2107-4	13 x15	370	A2107-8	22 x24	435

## H.C.B-B2107

**NEW**

### EXTRA LONG OFFSET BOX WRENCH KIT (6 PCS)

(10 x 12, 12 x 14, 13 x 15, 16 x 18, 17 x 19, 22 x 24 mm)

加長平型梅花扳手組 (6 PCS)

(10x12, 12 x 14, 13 x 15, 16 x 18, 17 x 19, 22 x 24 mm)



## H.C.B-A2177

### 5 PCS HALF-MOON RING WRENCH

5 PCS 扳手 (半月型)

- Material: Chrome vanadium ,  
Shiny finished
- 材質：鉻釩鋼，亮面處理



H.C.B-A2177-5  
H.C.B-A2177-4  
H.C.B-A2177-3  
H.C.B-A2177-2  
H.C.B-A2177-1

SIZE	L(mm)	ITEM NO.	C(mm)	B(mm)	C1(mm)	B1(mm)	T(mm)	WT(g)
10x12	141	H.C.B-A2177-1	15.6	18.2	6.6	6.5	4.2	56
11x13	166	H.C.B-A2177-2	18.2	21.0	8.2	8.0	4.9	93
14x17	190	H.C.B-A2177-3	22	25	9.2	8.2	5.3	134
16x18	220	H.C.B-A2177-4	25.5	28	9.6	8.8	5.6	180
19x22	256	H.C.B-A2177-5	28.6	32.5	11.1	10.1	6.6	240

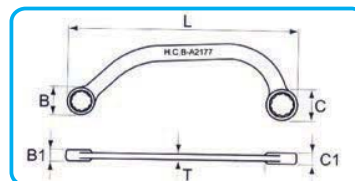



011

HWANG CHERNG BIN  
Specialty Tools Inc.

通用卡車修護工具

General Truck Repair Tool



General Truck  
Repair Tool

## H.C.B-B2192

## OIL DRAIN REPAIR KIT

油底殼螺絲更換組

8 / 20 / 21 / 2.2'

- Renew the thread and replace a new oil drain plug.
- Six popular sizes fit nearly all applications.
- Material:  
Tap: SKS3  
Oil drain plug: 1015  
Washer: Copper

- 重製螺牙並更換新的油底殼螺絲。
- 六種最常用的規格，可適用於大部份車種。
- 材質：  
攻牙器：SKS3  
油底殼螺絲：1015  
墊片：銅

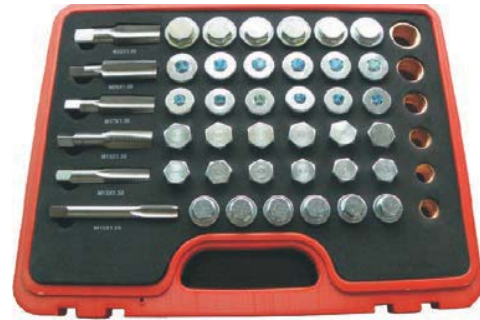

Size	Tap	Oil drain plug	Washer
M13 x P1.25	1 pc	6 pcs	12 pcs
M13 x P1.5	1 pc	6 pcs	12 pcs
M15 x P1.5	1 pc	6 pcs	12 pcs
M17 x P1.5	1 pc	6 pcs	12 pcs
M20 x P1.5	1 pc	6 pcs	12 pcs
M22 x P1.5	1 pc	6 pcs	12 pcs



## H.C.B-A1641

NEW

## UNIVERSAL LOCKING RING TOOL PAT.

萬能扣環鉗

- A new type of lock ring tool which makes dismounting and mounting of wheel bearing lock rings very easy.
- The tool is designed to fit the larger lock rings for example the lock ring on the axle shaft or other lock rings on passenger cars, light commercial vehicles and trucks.
- Content:  
A1641-025 Circlip pin 2.5 mm, 2 pcs  
A1641-030 Circlip pin 3 mm, 2 pcs  
A1641-035 Circlip pin 3.5 mm, 2 pcs



- 此新式扣環鉗可以非常輕鬆的拔除或安裝輪軸培林的C型環。
- 此扣環鉗可適用於較大型之C型環，如：轎車輪軸上之C型環，或其它轎車、輕型商用車及卡車上的C型環。
- 扣環插銷規格：  
A1641-025 扣環插銷 2.5 mm, 2 pcs  
A1641-030 扣環插銷 3 mm, 2 pcs  
A1641-035 扣環插銷 3.5 mm, 2 pcs

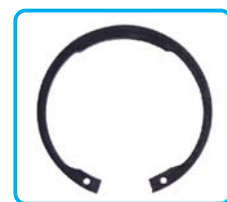











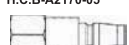
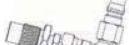

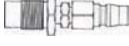
H.C.B-A2170

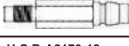
DIESEL ENGINE COMPRESSION TESTER KIT

柴油引擎汽缸壓力測試工具組

ITEM NO.	APPLICATION	ENGINE	TESTING PORT	THREAD
H.C.B-A2170-02 	Ford/Navistar	6.9 and 7.3 liter	glow plug	10mm -1.00
	General Motors	4.3 & 5.7 liter	glow plug	10mm -1.00
	Navistar	6.9 & 7.3 liter	glow plug	10mm -1.00
H.C.B-A2170-03 	Audi	all	fuel injector	24mm - 2.00
	Cummins	6 BT, 4.02" bore, 5.9 liter	fuel injector	24mm - 2.00
	Mercedes Benz	cars & trucks with 24mm ports	fuel injector	24mm - 2.00
	Volkswagen	all cars and trucks	fuel injector	24mm - 2.00
	Volvo	all cars and trucks	fuel injector	24mm - 2.00
H.C.B-A2170-04 	Cummins	V-185, V-210, V-225, V-555, VT-255, VT-555	fuel injector	
H.C.B-A2170-05 	Bacharach	Allow a Bacharach brand adapter to be used with our tester, No. H.C.B-A2170-01.		
H.C.B-A2170-06 	Mercedes Benz	12mm is for Model 300 & 300 Turbo diesel from 1978 and the 250 & 350 Turbo models.	glow plug	12mm - 1.25 and 18mm - 1.50
		18mm is for all regular Mercedes Benz engines & model 300 prior to 1978		
H.C.B-A2170-07 	Allis Chalmers	6000, 7000, 10000, 11000	fuel injector	
	Bedford	200, 220, 300, 330, 466	fuel injector	
	Case, J.I.	all models not using pencil nozzle	fuel injector	
	Deere, John	404, 466, 531, 619	fuel injector	
	Fiat Allis	8035-02-300, 8035-02-301, 8035-02-302, 8045-02, 8045-03	fuel injector	
	Ford Tractor	all	fuel injector	
	International Harvester	D/DT 361, D/DT 429, DV462, DV/DVT 550, DT/DV/DVT 573, 361, 407	fuel injector	
	Mack Truck	END 405, 457, 475, 510, 519, 605, 672, 673, 674,	fuel injector	
H.C.B-A2170-07		711, 864, ENDT-673, 675, 676, 865, 866		
	Onan	DSL, MDSL	fuel injector	
	Waukesha	180DLC,190D,195D,197D	fuel injector	
H.C.B-A2170-08 	Cummins	These 5.5" bore engines: NH(855 cubic inches), V-6, V-8, V-12 & 903 V-8 Cylindrical PTB	fuel injector	
H.C.B-A2170-09 	BMW	2.4 liter	glow plug	12mm - 1.25
	Lincoln Continental Mark VII	1984 and 1985 car models	glow plug	12mm - 1.25
	Peugeot	For Peugeot diesel passenger cars having either 12mm -1.25 or 18mm -1.50mm glow plug port holes	glow plug	12mm - 1.25 and 18mm - 1.50
H.C.B-A2170-10 	Chevy Luv	1.8 and 2.2 liter	glow plug	10mm - 1.25
	Isuzu	1.8 and 2.2 liter	glow plug	10mm - 1.25
	Toyota	1.8 liter	glow plug	10mm - 1.25
H.C.B-A2170-11 	General Motors	4.3, 5.7,6.2 liter, 6.5 liter Turbo	glow plug	10mm - 1.25
H.C.B-A2170-12 	Detroit Diesel	53, 71, 92, 110, 149, V53, V71 with low or high clamp injector hold down	fuel injector	
H.C.B-A2170-13 	Caterpillar	"Capsule" type nozzles including models D-336,1674, 1676, 3406, 3408 and 3412	fuel injector	
H.C.B-A2170-14 	Case, J.I.	70 series, 188 & 207 C.I.D. pencil nozzle	fuel injector	
	Caterpillar	1100 and 3208 series	fuel injector	
	Deere, John	early 300, 400 and 500 series, 276, 404, and 531 C.I.D.	fuel injector	
	Waukesha	D155D	fuel injector	







## H.C.B-A1320

### SPECIAL SOCKET FOR TRUCK (Dr. 3/4", 6 POINTS)

卡車特殊套筒 (Dr. 3/4", 6角)

H.C.B-A1320



## H.C.B-B1320

### SPECIAL SOCKET FOR TRUCK (Dr. 1", 6 POINTS)

卡車特殊套筒 (Dr. 1", 6角)

- Sample of application of A1320-95 & B1320-95:  
To remove / install Renault 10 wheels trailer (P370) drive axle nut.
- A1320-95 & B1320-95的使用例：  
移除 / 安裝雷諾10輪拖車頭(P370)的帶動軸螺帽



H.C.B-B1320

#### ■ Specification:

Item no.	Dr.	SW	Item no.	Dr.	SW
H.C.B-A1320-70	3/4"	70mm	H.C.B-B1320-70	1"	70mm
H.C.B-A1320-75	3/4"	75mm	H.C.B-B1320-75	1"	75mm
H.C.B-A1320-80	3/4"	80mm	H.C.B-B1320-80	1"	80mm
H.C.B-A1320-85	3/4"	85mm	H.C.B-B1320-85	1"	85mm
H.C.B-A1320-90	3/4"	90mm	H.C.B-B1320-90	1"	90mm
H.C.B-A1320-95	3/4"	95mm	H.C.B-B1320-95	1"	95mm
H.C.B-A1320-100	3/4"	100mm	H.C.B-B1320-100	1"	100mm
H.C.B-A1320-105	3/4"	105mm	H.C.B-B1320-105	1"	105mm
H.C.B-A1320-110	3/4"	110mm	H.C.B-B1320-110	1"	110mm
H.C.B-A1320-115	3/4"	115mm	H.C.B-B1320-115	1"	115mm
H.C.B-A1320-120	3/4"	120mm	H.C.B-B1320-120	1"	120mm
H.C.B-A1320-125	3/4"	125mm	H.C.B-B1320-125	1"	125mm
H.C.B-A1320-130	3/4"	130mm	H.C.B-B1320-130	1"	130mm
H.C.B-A1320-135	3/4"	135mm	H.C.B-B1320-135	1"	135mm
H.C.B-A1320-140	3/4"	140mm	H.C.B-B1320-140	1"	140mm
H.C.B-A1320-145	3/4"	145mm	H.C.B-B1320-145	1"	145mm
H.C.B-A1320-150	3/4"	150mm	H.C.B-B1320-150	1"	150mm
H.C.B-A1320-155	3/4"	155mm	H.C.B-B1320-155	1"	155mm
H.C.B-A1320-160	3/4"	160mm	H.C.B-B1320-160	1"	160mm
H.C.B-A1320-165	3/4"	165mm	H.C.B-B1320-165	1"	165mm
H.C.B-A1320-170	3/4"	170mm	H.C.B-B1320-170	1"	170mm
H.C.B-A1320-175	3/4"	175mm	H.C.B-B1320-175	1"	175mm
H.C.B-A1320-180	3/4"	180mm	H.C.B-B1320-180	1"	180mm
H.C.B-A1320-185	3/4"	185mm	H.C.B-B1320-185	1"	185mm
H.C.B-A1320-190	3/4"	190mm	H.C.B-B1320-190	1"	190mm
H.C.B-A1320-195	3/4"	195mm	H.C.B-B1320-195	1"	195mm
H.C.B-A1320-200	3/4"	200mm	H.C.B-B1320-200	1"	200mm

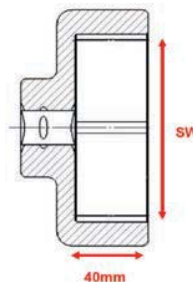

Renault 10 wheels trailer (P370) drive axle nut

Item no .	Dr.	SW	Length
H.C.B-A1320-30	3/4"	30mm	90L
H.C.B-A1320-32	3/4"	32mm	90L
H.C.B-A1320-33	3/4"	33mm	90L
H.C.B-A1320-34	3/4"	34mm	90L
H.C.B-A1320-35	3/4"	35mm	90L
H.C.B-A1320-36	3/4"	36mm	90L
H.C.B-A1320-38	3/4"	38mm	90L
H.C.B-A1320-41	3/4"	41mm	90L
H.C.B-A1320-46	3/4"	46mm	90L





通用卡車修護工具

General Truck Repair Tool



011

HWANG CHERNG BIN  
Specialty Tools Inc.



## H.C.B-B1320-7090

SPECIAL SOCKET FOR TRUCK  
(Dr. 1", 70 mm, LENGTH 90 mm)

卡車特殊套筒(Dr. 1", 70 mm, 長度: 90mm)

- Size: DR. 1", 70 mm, LENGTH 90 mm
- 尺寸: DR. 1", 70 mm, 長度90 mm

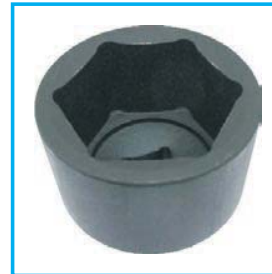

## H.C.B-A1488

SPECIAL SOCKET FOR TRUCK(Dr. 3/4", 8 POINTS)

卡車輪軸螺帽套筒 (Dr. 3/4", 8角)

## H.C.B-B1488

SPECIAL SOCKET FOR TRUCK(Dr. 1", 8 POINTS)

卡車輪軸螺帽套筒(Dr. 1", 8角)



L: 88 mm

Item	Dr.	SW	Item	Dr.	SW
A1488-70	3/4"	70mm	B1488-70	1"	70mm
A1488-75	3/4"	75mm	B1488-75	1"	75mm
A1488-80 (B1125)	3/4"	80mm	B1488-80 (C1125)	1"	80mm
A1488-85	3/4"	85mm	B1488-85	1"	85mm
A1488-90	3/4"	90mm	B1488-90	1"	90mm
A1488-95	3/4"	95mm	B1488-95 (A1050-8)	1"	95mm
A1488-100 (B1126)	3/4"	100mm	B1488-100 (C1126)	1"	100mm
A1488-105	3/4"	105mm	B1488-105	1"	105mm
A1488-110	3/4"	110mm	B1488-110	1"	110mm
A1488-115 (A1176)	3/4"	115mm	B1488-115	1"	115mm
A1488-120	3/4"	120mm	B1488-120	1"	120mm
A1488-125	3/4"	125mm	B1488-125	1"	125mm
A1488-130	3/4"	130mm	B1488-130	1"	130mm
A1488-135	3/4"	135mm	B1488-135	1"	135mm
A1488-140	3/4"	140mm	B1488-140	1"	140mm
A1488-145	3/4"	145mm	B1488-145	1"	145mm
A1488-150	3/4"	150mm	B1488-150	1"	150mm
A1488-155	3/4"	155mm	B1488-155	1"	155mm
A1488-160	3/4"	160mm	B1488-160	1"	160mm
A1488-165	3/4"	165mm	B1488-165	1"	165mm
A1488-170	3/4"	170mm	B1488-170	1"	170mm
A1488-175	3/4"	175mm	B1488-175	1"	175mm
A1488-180	3/4"	180mm	B1488-180	1"	180mm
A1488-185	3/4"	185mm	B1488-185	1"	185mm
A1488-190	3/4"	190mm	B1488-190	1"	190mm
A1488-195	3/4"	195mm	B1488-195	1"	195mm
A1488-200	3/4"	200mm	B1488-200	1"	200mm



尺寸: Dr. 3/4" , 8角, 105 mm

General Truck Repair Tool



011

HWANG CHERNG BIN  
Specialty Tools Inc.

通用卡車修護工具

General Truck Repair Tool



General Truck  
Repair Tool

### H.C.B-A1592

### SPECIAL SOCKET FOR TRUCK (Dr. 1", 12 POINTS, L: 90 mm)

卡車特殊套筒(Dr. 1" · 12 角 · 長度 : 90 mm)

- Application: IVECO truck      適用車種: IVECO卡車
- Size: Dr. 1", 12 POINTS, L: 90 mm      尺寸: Dr. 1", 12角, L: 90 mm
- Specification:

Item No.	Dr.	SW
H.C.B-A1592-80	1"	80mm
H.C.B-A1592-85	1"	85mm
H.C.B-A1592-90	1"	90mm
H.C.B-A1592-95	1"	95mm
H.C.B-A1592-100	1"	100mm
H.C.B-A1592-105	1"	105mm
H.C.B-A1592-110	1"	110mm
H.C.B-A1592-115	1"	115mm
H.C.B-A1592-120	1"	120mm



### H.C.B-A1336

### MANUAL LINING PULLER KIT

手動汽缸套拔卸組

- This set removes cylinder lining from most truck (such as FUSO 3.5 tons, 15 tons, 330, HINO 750, VOLVO (FL10, FM12) SCANIA 310), buses and other vehicle engines.
- This set doesn't need to removal the head studs.
- 可以取出大部份卡車(如: FUSO 3.5噸、15噸、330、HINO 750 VOLVO (FL10, FM12)、SCANIA 310)、巴士和汽車的引擎汽缸套。
- 不需移除汽缸頭銷。

VIDEO



Part No.	I.D.-0.1	O.D.-0.1	Application
HCB-A1336-10	φ 119	φ 130	
HCB-A1336-11	φ 129	φ 142	FUSO 330, 350
HCB-A1336-12	φ 126	φ 138.5	SCANIA 310
HCB-A1336-13	φ 134	φ 140	
HCB-A1336-14	φ 136.5	φ 147	FUSO V8 330
HCB-A1336-15	φ 126	φ 140	SCANIA 320
Optional			
HCB-A1336-16	φ 120	φ 125	VOLVO(FL10)
HCB-A1336-17	φ 130	φ 135	VOLVO(FM12)
HCB-A1336-18	φ 129.5	φ 138.5	DAF

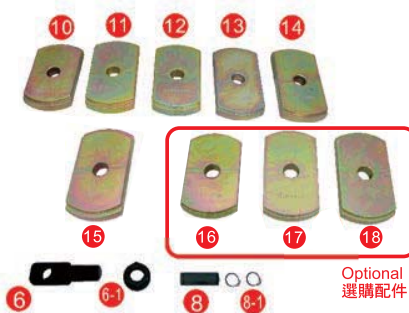

Optional  
選購配件







### H.C.B-A1337

### TRUCK K/D RACK - MANUAL PAT. I 380921

手動卡車多功能拆裝架

- The gear type truck K/D rack is designed for engine or transmission maintenance.
- Replaceable holding base to fit any kinds of engine and transmission.
- Padlocked turbine case helps technicians check the turbine easily.
- The gear and engine / transmission can be rotated on 360 degrees synchroual both clockwise and reverse.
- Stop at any angles if necessary.
- Extendable stand for storage.
- Capacity: 1500 LB
- Size: L: 1600 mm (extended) / 1140 mm W: 1000 mm H: 1360 mm
- N.W.: 347 Kgs

- 專為維修引擎、變速箱而設計。
- 可更換式的固定座適用於各種引擎、變速箱。
- 鉸鏈式箱門，方便渦輪日常保養。
- 可360°、雙向轉動引擎、變速箱。
- 可固定在任何角度。
- 伸縮腳架，方便收藏儲放。
- 載重量：1500 磅
- 尺寸：長：1600 mm(延伸)/1140 mm  
寬：1000 mm 高：1360 mm
- 淨重：347公斤

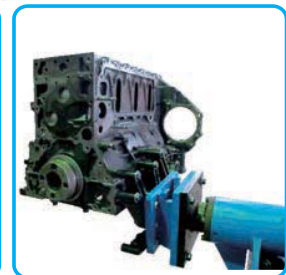
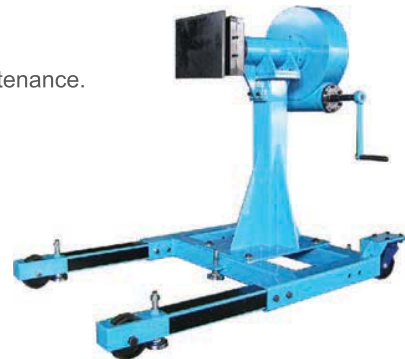

### H.C.B-B1337

### TRUCK K/D RACK - ELECTRICAL PAT. I 380921

電動卡車多功能拆裝架

- The best truck K/D rack for both engine and transmission maintenance.
- Replaceable holding base to fit any kinds of engine and transmission.
- Padlocked turbine case helps technicians check the turbine easily.
- The gear and engine / transmission can be pivoted on 360 degrees both clockwise and reverse.
- Stop at any angles and any time if necessary.
- Driven by 2HP motor. The patented design of H.C.B
- Extendable stand for storage.
- Capacity: 1500 LB
- Specification of power:      ■ Size:
- Power 2HP motor                      L: 1600 mm (extended) / 1140 mm
- Resource Single-phase, 220V      W: 1000 mm
- Control Wire 3 m                      H: 1360 mm
- Power Cord 5 m
- N.W.: 376 Kgs

- 專為維修引擎、變速箱而設計。
- 可更換式的固定座適用於各種引擎、變速箱。
- 鉸鏈式箱門，方便渦輪日常保養。
- 可360°、雙向轉動引擎、變速箱。
- 可固定在任何角度。
- 本公司專利設計，由2HP馬達驅動。
- 伸縮腳架，方便收藏儲放。
- 載重量：1500磅
- 馬達規格：      ■ 尺寸：
- 2HP馬達                      長：1600 mm(延伸) / 1140 mm
- 單向，220V                      寬：1000 mm
- 控制器線長：3 m                      高：1360 mm
- 電源線長：5 m
- 淨重：376公斤

VIDEO

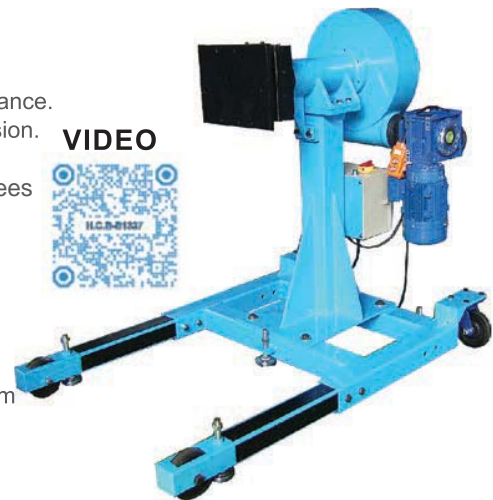



011

HWANG CHERNG BIN  
Specialty Tools Inc.

通用卡車修護工具

General Truck Repair Tool



General Truck  
Repair Tool

### H.C.B-C1337

### TRANSMISSION FIXED BASE

卡車變速箱固定座

- Size : 690 mm x 770 mm x 600 mm
- Application: Most of Japanese trucks.
- 尺寸 : 690 mm x 770 mm x 600 mm
- 適用車種 : 大部份的日系卡車



### H.C.B-D1337

### DIFFERENTIAL FIXED BASE

卡車差速器固定座

- Application: UD WC520 two-way differential.
- 適用車種 : UD WC520雙轉差速器



### H.C.B-E1337

NEW

### CUMINS ENGINE FIXED BASE (EURO 4)

康明斯引擎固定架(四期環保)

- Application: Cumins (Euro 4)
- 適用車種: 康明斯引擎 四期環保



### H.C.B-A1339

### TRUCK KING PIN PRESS (30 TONS) DE. PAT. M459081

大王銷拆卸機 (30噸)

- To turn the handle and adjust angles to push out stubborn king pin and anchor pin.
- Application: Most of trucks and buses.
- To combine with H.C.B-B3036.
- Size: 1120 mm (L) x 520 mm (W) x 910 mm (H)
- Capability: 30 tons
- 轉動手把、調整角度來拉出卡住的大王銷、固定銷。
- 適用車種 : 大部份的卡車、遊覽車
- 搭配H.C.B-B3036使用。
- 尺寸 : 1450 mm (長) x 500 mm (寬) x 1550 mm (高)
- 油壓缸 : 30噸



VIDEO







通用卡車修護工具

General Truck Repair Tool



011

HWANG CHERNG BIN  
Specialty Tools Inc.



## H.C.B.-B1339

## TRUCK KING PIN PRESS (75 TONS) DE. PAT. M459081

大王銷拆卸機 (75噸)

Sleeve set 配件組

VIDEO

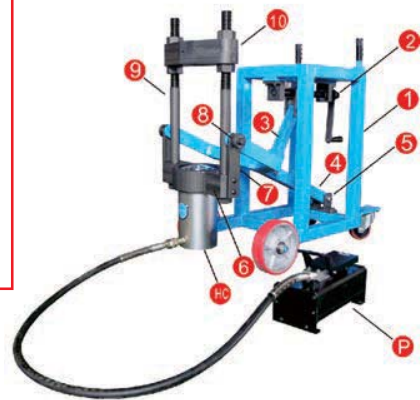

Sleeve set consists of:  
拆裝配件組包含：

Technical Data	
Transport cart size 車架尺寸	L:1120 x W:520 x H:910(mm)
Hydraulic cylinder 油壓缸	75 tons
Stroke 油壓缸行程	140 mm
Clearance between puller bolts 拆卸螺絲間距 (P.C.D)	300 mm
Clearance height 上座移動間距	320mm~430mm
Air Pump 幫浦	H.C.B-B3036(1800c.c)
Cart Lift 車架舉升高度	350mm-580mm
Weight 重量	Approx.172kgs

Description	Qty
11 Support sleeve 支撐座更換套	1
12 Support sleeve 支撐座更換套	1
13 Support sleeve 支撐座更換套	1
14 Mandrel adaptor 頂桿接頭	1
15 Mandrel 頂桿	1
16 Mandrel 頂桿	1
17 Mandrel 頂桿	1
18 Mandrel 頂桿	1
19 Mandrel 頂桿	1
20 Remove Sleeve 拆卸套	1
7-3 Connecting Arm 連接臂	2



### Reason for replacing King Pin bearing:

King Pin bearing will loosen after driving for long-term period and this will cause front wheel alignment problem and it would be dangerous to drivers.

### Description:

This press can assemble and disassemble KING PIN on European trucks and Japanese trucks for replacing bearing or sleeve.

Save time, labor and money!

### Product features:

- Have great mobility
- It can be upwards and downwards (rotatable 180°) depends on position of King pin when assembly or disassembly.
- With 75 tons hydraulic cylinder & B3036 pump (1800 c.c.)
- Application: European trucks & Japanese trucks.

### 使用說明:

此工具是用來拆卸歐系、日系卡車的大王銷，目的是要更換大王銷培林或銅套。省時、省力又省錢。

### 更換原因:

歐系、日系卡車，因長期行駛而造成大王銷培林鬆動，進而影響前輪定位，造成駕駛開車危險，所以要更換大王銷培林。

### 工具特性:

- 此工具易於移動，機動性良好。
- 可旋轉之基座(180度)，隨著各卡車大王銷位置差異可作調整。由下壓出或往上壓出大王銷皆可適用。
- 需配合75噸油壓缸及搭配產品B3036一起使用。
- 適用車種：歐系、日系卡車。

## H.C.B.-A1435

## KENWORTH TRUCK REAR AXLE NUT SOCKET (SW 4", 6 POINTS, Dr. 3/4")

KENWORTH卡車後輪軸螺帽套筒(SW 4", 6角, Dr. 3/4")

- The unique design and profile of the socket make it perfectly match the position and prevent the damage of axle nut.
- The robust socket is manufactured from a piece of material.
- It can be used with torque wrench.
- Size: Dr. 3/4", 6 points, SW 4"
- Application: KENWORTH Truck
- 獨特輪廓設計的套筒使它與螺母吻合，可輕易拆卸而不傷及零件。
- 由一整塊材料切割而成的套筒，使它更為堅固及耐用!
- 可搭配扭力扳手使用!
- 尺寸: Dr. 3/4"，6角, SW 4"
- 適用車種: KENWORTH卡車



KW TRUCK NUT



**H.C.B-C1339**
**TRUCK KING PIN PRESS (75 TONS) DE. PAT. M459081**

大王銷拆卸機(75噸)

- King Pin bearing will loosen after driving for long-term period and this will cause front wheel alignment problem and it would be dangerous to drivers.
- Description:
  1. This press can assemble and disassemble KING PIN on European trucks and Japanese trucks for replacing bearing or sleeve.
  2. Save time , labor and money!
  3. With the revised bar, you can turn it 360° .
- Product features:
  1. Have great mobility
  2. It can be upwards and downwards (rotatable 180°) depends on position of King pin when assembly or disassembly.
  3. With 75 tons hydraulic cylinder & H.C.B-B3036 pump (1800 c.c.)
  4. Application: European trucks & Japanese trucks.

**■ 產品特色:**

在使用過程中，具及高度靈活性  
 此設備之Y型架可依據大王銷位置翻轉，旋轉角度達360°。  
 配有75噸油壓缸與H.C.B-B3036汽動幫浦(1800 c.c.)  
 適用車種: 歐系卡車與日系卡車

**H.C.B-A2050**
**CAST STEEL SWIVEL-BASE VISE (6")**

老虎鉗(6")

**H.C.B-A2050-1**
**CAST STEEL SWIVEL-BASE VISE (8")**

老虎鉗(8")

**H.C.B-A2050-2**
**CAST STEEL SWIVEL-BASE VISE (10")**

老虎鉗(10")

**H.C.B-B2050**
**CAST IRON VISE (6")**

老虎鉗(6")

- 360° swivel base
- Material: High quality cast iron
- 360° 旋轉底座
- 材質：高級鑄鐵

**H.C.B-A2094**
**TWO WAY OIL FILTER WRENCH (60~80 mm)**

二爪正反轉機油芯扳手 (60~80 mm)

**50 / 24.9 / 27.2 / 1.78'**

- The tool is used for removing and installing the oil filter
- Use with Dr. 1/2" or 21 mm wrench.
- Size: range 60-80 mm
- 可用來拆卸和安裝機油芯。
- 可搭配Dr. 1/2"或21 mm扳手使用。
- 尺寸：60-80 mm





通用卡車修護工具

General Truck Repair Tool



011

HWANG CHERNG BIN  
Specialty Tools Inc.



General Truck  
Repair Tool

### H.C.B-B2094

TWO WAY OIL FILTER WRENCH (80~110 mm)

二爪正反轉機油芯扳手 (80~110 mm)

25 / 24 / 25 / 1.6'

- The tool is used for removing and installing truck oil filter . The serrate design makes it set in place.
- Use with Dr. 1/2" or 22 mm wrench.
- Size: range 80-110 mm
- 可用來拆卸和安裝機油芯。鋸齒狀設計，可將工具固定在正確位置。
- 可搭配Dr. 1/2"或22 mm扳手使用。
- 尺寸：80-110 mm



### H.C.B-D2094

TWO WAY OIL FILTER WRENCH (104~150 mm)

二爪正反轉機油芯扳手 (104~150 mm)

- The tool is for removing and reinstalling oil filter.
- Use with Dr. 1/2" or 24 mm wrench.
- Size: range 104~150 mm
- Application: European, Japanese, American cars and FUSO 10.5~17 tons EURO 4.
- 可用來拆卸和安裝機油芯。
- 可搭配Dr. 1/2"或24 mm扳手使用。
- 尺寸：104-150 mm
- 適用車種：歐系、日系、美系車輛及FUSO 四期環保10.5-17噸卡車



### H.C.B-A2121

PORTABLE POWER STATION (FOR SEDAN)

電霸 (一般轎車用)

3 / 28.5 / 29.5 / 0.58'



Battery : 12V/17AH



### H.C.B-B2121

PORTABLE POWER STATION (FOR SEDAN)

電霸 (汽油車, 柴油車用)

3 / 26 / 26.5 / 2.03'

- Don't worry when your car's battery is dead.
- Prevent audio or computer from shutting down when changing the car battery.
- Power supplier for home electric appliances.
- Emergency power supply.
- Easy and quick charge.
- Portable, rechargeable, cordless, easy to carry along in vehicles or boats.
- Powerful enough to start engine.
- No need other vehicle or booster cables.
- Safe and sealed battery won't be leak or spill.
- Polarity protection device if clamps connected to battery poles in reverse. And prevent clamps from sparking if the two clamps touched together.

- 當車輛電瓶沒電時，毋需擔心。
- 可避免在更換電瓶時，發生音響或電腦當機。
- 可使用家用電源來充電。
- 緊急的電源供應器。
- 充電簡單、快速。
- 手提、可重覆充電、無線，易於攜帶在車或船上。
- 強效電力，可啟動引擎。
- 不需要其他車輛或電纜。
- 安全、密封式電池，不用擔心溢漏。
- 電極保護裝置可避免接錯電或兩個夾子互相接觸引發的短路。





011

HWANG CHERNG BIN  
Specialty Tools Inc.

通用卡車修護工具

General Truck Repair Tool



General Truck  
Repair Tool

## H.C.B-C2121

## PORTABLE POWER STATION ( 230V/50Hz)

電霸 (230V/50HZ)

2 / 18.5 / 19 / 1.6'

- LED Operation Function:  
The power station voltage level is indicated by the LED's:  
Green >12.8V  
Yellow 12.2-12.7V  
Red <12V
- Low Voltage Warning Buzz warning for low battery and naturally discharge/ unload the voltage down to 7V ± 0.5V.

Battery LED indicators



- LED指示功能：電霸的電量可由LED的燈色來表示。  
綠 > 12.8V  
黃 12.2-12.7V  
紅 < 12V
- 低電量、或電量不足7V ± 0.5V時，會響起警告聲。

## H.C.B-D2121

## PORTABLE POWER STATION (FOR VEHICLE)

電霸(電力士)

6 / 23.5 / 24 / 1.11'



- It's the lightest in the market, the weight only 3.3 kg , easy operation and store.
- Powerful enough to start engine of under 3500 c.c.vehicle
- It can supply power alone , don't need another vehicle
- The battery charger is designed automatic disconnection power supply so battery life can be prolonged
- It also can supply for lots of equipment of vehicle (ex. mobile phone , intercom of vehicle, vacuum cleaner)
- 淨重3公斤，是市售最輕的電霸。便於操作和存放。
- 強效的電力，足以發動3500c.c.以下的車輛引擎。
- 可單獨供電，不需藉助其他的車輛。
- 自動斷電設計，可延長電霸的壽命。
- 也可以做為車上其他設備的電源。(例如：手機、對講機和吸塵器)

## H.C.B-B2294

NEW

## LED WORK LIGHT

LED工作燈

Characters:

- This light has powerful magnet and hook which can rotate 360 degree freely and attach or hang on any place.
- This light is with cooling function which can extend the life-span of LEDs, prevents the LEDs from light fades, and ensures the quality.

特色:

- 裝有強力磁鐵與掛勾，可360度任意旋轉吸附或吊掛在任何位置上。
- 具散熱功能，可確保LED壽命，可使LED無法光衰與確保產品品質

應用範圍:

- 汽車工作燈、汽車日型燈、汽車車底燈、汽卡車室內外燈、卡車日型燈、卡車車底燈、室內、室外、登山露營、釣魚、廚櫃燈、緊急照明燈具、層板燈







通用卡車修護工具

General Truck Repair Tool



011

HWANG CHERNG BIN  
Specialty Tools Inc.



General Truck  
Repair Tool

## H.C.B-C2294

**NEW**

### LED POWER PACK LIGHT

#### LED行動電源工作燈

- The mobile power can be removed to be used as an independent mobile power. It can support power to mobile phone or PAD.
- The body is with strong magnet.
- The slim body designed can be used in narrow place.
- The power with safety device of excessive charged or excessive discharged.
- The lamp have red glitter function, it can used as a warning lamp.

#### Specification:

Light color: White / Red warning lamp.

Input voltage: 5V/1A (Micro USB)

Output voltage: 5V/1A (USB)

Capacity battery: 2600 mAh

Rated capacity: 5V/1560 mAh/7.8Wh

Length/ Weight/ Height: 24 mm/24 mm/300 mm

Material: Circuit boards, aluminum, iron, lithium battery, plastic



#### 特色:

- 行動電源可以拆下，做為獨立的行動電源使用，可供手機或平板電腦等行動裝置充電
- 細長式設計可深入狹窄位置照明
- 設有電池過充/過放電安全保護裝置
- 具紅燈閃爍功能，可當警示燈使用

#### 應用範圍:

- 汽車修護工作燈、戶外休閒、登山露營、釣魚、緊急照明等場所、警示燈、加油棒

## H.C.B-C2195

**NEW**

### ANGLE ADJUSTABLE 30PCS LED WORKING LIGHT AC/DC RECHARGEABLE BATTERY

#### LED工作燈(附磁鐵)



#### ■ Specification:

- A. LED quantity: 30pcs of LED with top light LEDx4 or 3W LEDx1 or U.Vx1
- B. LI-ION rechargeable battery: 3.7V 2200mAh.
- C. Charger input: AC100 ~ 240V 50/60Hz /DC12V~24V
- D. Power output: 5.0V 1000mAh.
- E. Charger time: 3.5 ~ 4.0 hours.
- F. Active time: 4~5 hours

#### ■規格表

- A. LED數量:30PCS
- B. 鋰電池: 3.7V, 2200mAh
- C. 輸入電壓: AC100~240V, 50/60Hz/  
DC12V~24V
- D. 輸出: 5.0V 1000mAh
- E. 充電時間:3個半小時到4小時
- F. 可使用時間: 4~5小時

**H.C.B-A2061**
**HEIGHTENED MANUAL HYDRAULIC PRESS (15 TONS)**

加高型手動油壓床 (15噸)

- Application: Using for wide range of mechanical parts, like bends deforms combined for reformation or shaft bearing, gear, pressed in or extruded.
- It is a very useful tool for vehicle or industry mechanical parts maintenance.
- Feature: High precision hydraulic press for industry.
- It is designed with double oil-cycle system.
- Press head assembly is movable to right and left sides.
- Press head and worktable are adjustable up and down for pressure process.
- A 600kg/cm<sup>2</sup> precision pressure gauge is included.
- N W · 160 KGS G.W.: 190 KGS

- 適用範圍：大範圍的機械加工。
- 例如：培林、齒輪加工成型。
- 車輛、工業零件維修的好工具。
- 高精密度的油壓。
- 雙油壓循環系統。
- 壓頭可向左、右轉動。
- 壓頭和工作檯都可以調整高低。
- 配備有精密的油壓表。(600公斤/公分<sup>2</sup>)
- 淨重：160公斤，毛重：190公斤

**H.C.B-A2197**
**HEAVY DUTY OIL FILTER CHAIN WRENCH (350 mm)**

鏈條式機油濾芯扳手 (350 mm)

**24 / 19.2 / 20.2 / 2'**

- Applicable for all type of oil filter.
- Flexible handle for narrow space using.
- Size available:  $\varnothing$  60 mm-105 mm.
- Length of chain: 350 mm.
- 適用於各種類型的機油芯。
- 彈性把手，方便在狹小空間中操作。
- 適用尺寸： $\varnothing$  60 mm-105 mm
- 鏈條長度：350 mm

**H.C.B-B2197**
**HEAVY DUTY OIL FILTER CHAIN WRENCH (520 mm)**

鏈條式機油濾芯扳手 (520 mm)

**24 / 22.6 / 23.6 / 1.9'**

- Applicable for all type of oil filter.
- Flexible handle for narrow space using.
- Size available:  $\varnothing$  60 mm-160 mm.
- Length of chain: 520 mm.
- 適用於各種類型的機油芯。
- 彈性把手，方便在狹小空間中操作。
- 適用尺寸： $\varnothing$  60 mm-160 mm
- 鏈條長度：520 mm





通用卡車修護工具

General Truck Repair Tool



011

HWANG CHERNG BIN  
Specialty Tools Inc.



## H.C.B-A2128

## AIR HOSE REEL (10 METERS)

捲式風管 (10米)

4 / 21 / 25 / 4.27'

- 規格：  
PU風管可承受300 psi (20 bar)  
ABS外殼可防止撞擊  
防撞 / 防鏽基座  
組裝容易 (只需螺絲起子即可組裝)  
適用於商業、工業工作坊、維修廠和機械店  
180° 轉動的捲軸，可提供廣大工作範圍。  
也可以用45°、90° 和135° 角固定

■ Specification:

PU air hose is up to 300 psi (20 bar).  
ABS resin material, against impact.  
High impact / corrosion resistant base.  
Easy install (Reel mounts only requires screw driver for assembly.)  
Ideal for use in commercial / industrial workspaces, automotive garages and machine shops.  
Reel swivels 180° to cover a wide work area or can be installed at 45°, 90°, 135° fixed angle.

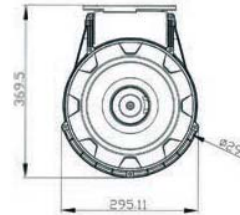
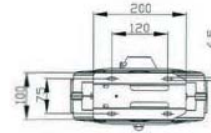

Model	Name	Specifications	Max Pressure
H.C.B-A2128	Air hose reel (10 meters)	Φ8 X Φ12 X 10M Φ5/16Φ X Φ15/32 X33FT	300 psi

## H.C.B-B2128

## CORD REEL

捲式三插座 4 / 21 / 25 / 4.27'

## H.C.B-C2128

## CORD REEL+110V WORK LIGHT

捲式三插座+日光燈 (110V)

4 / 22.5 / 26 / 4.27'



H.C.B-B2128

H.C.B-C2128

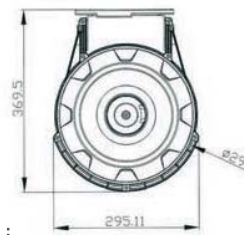
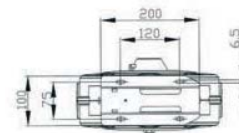

■ Specification:

Plug can reach nearly outlet 3.3 FT.  
ABS resin material against impact.  
High impact / corrosion resistant base.  
JIS(Japanese Industrial Standard) standard copper material.  
Easy to install, lead wire with plug cap, plugs into nearest receptacle.  
Three outlets for use by three electric tools / appliances simultaneously.  
Easy installation-(Reel mounts only requires screw driver for assembly).  
Ideal for use in commercial / industrial workspaces, automotive garages and machine shops.  
Reel swivels 180° to cover a wide work area or can be installed at 45°, 90°, 135° fixed angle.

■ 規格：

風管可拉長至接近3.3呎  
ABS外殼可防止撞擊  
防撞 / 防鏽基座  
符合JIS規格的銅材製造  
電線和插座蓋安裝容易  
三個插座，可供應三項電器使用  
組裝容易 (只需螺絲起子即可組裝)  
適用於商業、工業工作坊、維修廠和機械店  
180° 轉動的捲軸，可提供廣大工作範圍。  
也可以用45°、90°和135°角固定

Model	Name	Specification	Max Voltage	AMP
H.C.B-B2128	Cord reel	2.0 mm <sup>2</sup> X 3C X 10m 14AWG X 3C X33FT	100~120V	12A
H.C.B-C2128	Cord reel+110V work light	2.0 mm <sup>2</sup> X 3C X 10m 14AWG X 3C X33FT	100~120V	12A





**H.C.B-D2128**
**WATER HOSE REEL (8 METERS)**

水管捲揚器 (8米)

**4 / 22.8 / 26.3 / 4.27'**
**SPECIFICATIONS**

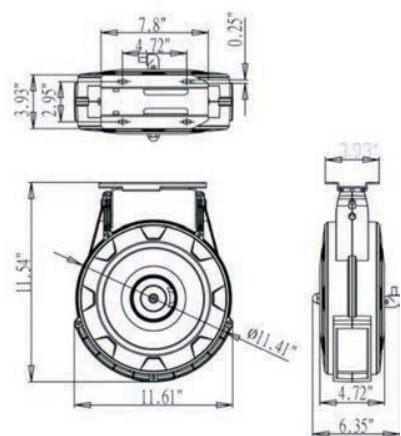
- ABS resin case, against impact
- Easy installation on the wall or the ceiling
- High impact and corrosion resistant base
- PVC water hose can bear up to 150 psi (10 bar)
- Suitable for commercial workspaces, industrial workspaces, automotive garages, and machine shops
- Free rotation within 180°, and can be installed at 45°, 90°, and 135° fixed angle
- Metal spray gun, heat and cold resistant



MODEL	NAME	SPECIFICATIONS	MAX PRESSURE
H.C.B-D2128	Water Hose Reel	φ 7.5 mm x φ 13 mm x φ 8 M φ 19/64" x φ 33/64" x φ 26 ft	150 psi

規格：

- ABS外殼可防止撞擊
- 易於安裝於牆上或屋頂上
- 防撞 / 防鏽基座
- PVC水管可耐受150 psi (10 bar)
- 適用於商業、工業工作坊、維修廠和機械店
- 180° 轉動的捲軸，可提供廣大工作範圍。
- 也可以用45°、90°和135°角固定
- 金屬噴槍，耐熱又耐寒

**H.C.B-A1412**
**TRUCK RADIATOR PRESSURE TEST KIT(9 PCS)**

卡車水箱測漏組(9 PCS)

- Measuring range 10-15 psi
- Check on pressure loss through gauge
- Possibility of testing locking caps
- Pressure test on the cooling system
- 測試範圍：10-15 psi
- 透過壓力錶來檢測水箱各管路是否有漏水
- 符合各種車種的水箱蓋
- 適用於卡車水箱

1	Pressure Testing Pump with Gauge
2	Connecting
3	DEUTZ ENGINE (1015) MB-Sprinter (-> 2006), - (Vito-2006)
4	MAN-L 2000(1993-2000), -TGA(2000-), DAF-CF(2000-).
5	IVECO-LKW-Daily 2000 C-Serie, Renault-Kerax(1999-),-Magnum(1990-2003),-Midlum(2000-),-Premium(1997-)
6	MB-Actros(1997-), -Atego(1998-), -Axor(2001-), -ECO 8401, LKW 1728, MAN-F90(1987-1996), -F2000(1995-2003), -E2000(2000-), TGA/L/M/S(2005), IVECO-EURO-Star(1993-2001), -EUROTech(1993-2001), EuroTruck, Euro trakker(2002-), -Strahls(2002-), -EUROCARGO(1991-), Euro Trakker Cursor(2002-), Euro Trakker Cursor 13(2001-), DAF-LF55(2001-) Volvo-FM
7	DAF-XF 95(2002-2006), -XF 105(2005-), ERF-EC RANGE(1996-2003),
8	Volvo -FH 12
9	Scania-4 SERIES(1995-2004), -93, -94(1996-2004), -113, -114(1996-2004), -124(1996-2004), -125, -144(1996-2002), -164(1999-2004)





通用卡車修護工具

General Truck Repair Tool



011

HWANG CHERNG BIN  
Specialty Tools Inc.



## H.C.B-A3005

## 10 TONS TWO SPEEDS DYNAMIC POWER KIT

10 噸雙段油壓鉸金組

- Quick "snap together" design for fast and easy assembly and disassembly.
  - Flexible hydraulic hose with spring guards at both ends.
  - Rugged & welding construction features its hand pump base is made by forging for resisting of oil leakage under collision & denting.
  - Components are also made by forging with the best rigidity and strength to ensure never broken during operation with high safety.
  - Each components are connected through female connector for easy operation.
- 快速接頭式設計，可迅速、簡便地組裝、拆解本工具組。
  - 彈性油壓管雙頭都附有保護彈簧。
  - 油壓缸以焊接方式和鍛造的底座連結，加強承載力。也可防止溢漏和塌陷。
  - 鍛造的零組件，可確保操作時的安全性。
  - 每個零組件都以母接頭連結，方便操作。



## H.C.B-A6001

## HYDRAULIC ELEVATOR CART (300 KGS)

油壓升降推車 (300 公斤)

Model 編號	Capacity 載重	Max Height 最大高度	Min Height 最小高度
H.C.B-A6001	300KGS(135.9LBS)	882mm	267mm

Table Size 標面尺寸	Net Weight 淨重	Handle 把手	Wheel 輪子
800mmx500mm	71.2KGS	Fix type	5.4 inch



## H.C.B-A1497

## ALUM-A-STACK HYDRAULIC RAM KIT

卡車堆疊式油壓組

- Convenient kit allows you to select your ram length.
- 10 tons ram include 1" (2.5 cm), 2"(5 cm) and 3" (7.5 cm) extensions.
- Extensions can be used individually or joined
- Ships in carrying case.
- Weight : 4.3 kg
- Retracted height- 3.5" (9 cm)
- Stroke length- 1.5" (3.8 cm)
- 此工具可換接頭，加長，輕巧，使用便順手，省時又省力





011

HWANG CHERNG BIN  
Specialty Tools Inc.

通用卡車修護工具

General Truck Repair Tool



General Truck  
Repair Tool

### H.C.B-A1481

VOLVO/ HINO REMOVAL TOOL FOR  
OIL FILTER (Dr. 1/2") (100-110 mm)

VOLVO/HINO 機油芯/油水分離器濾芯扳手 (Dr. 1/2") (100-110 mm)

### H.C.B-B1481

FUSO (10.5-17) TONS REMOVAL TOOL FOR  
OIL FILTER (Dr. 1/2") (110-125 mm)

FUSO (10.5-17) 噸機油濾芯扳手 (Dr. 1/2") (110-125 mm)

### H.C.B-C1481

MAN/SCANIA/DAF REMOVAL TOOL FOR AIR  
DRYER FILTER (Dr. 1/2") (125-140 mm)

MAN/SCANIA/DAF 四向閥乾燥濾芯 (Dr. 1/2") (125-140 mm)

### H.C.B-D1481

SCANIA REMOVAL TOOL FOR FUEL FILTER  
(Dr. 1/2") (70-80 mm)

SCANIA 柴油濾芯扳手 (Dr. 1/2") (70-80 mm)

### H.C.B-E1481

TRUCK REMOVAL TOOL FOR FUEL FILTER/OIL FILTER  
(80-90 mm)

卡車柴油/機油濾芯扳手(80-90 mm)

### H.C.B-F1481

EUROPEAN/JAPANESE TRUCK REMOVAL TOOL FOR  
FUEL FILTER/OIL FILTER (90-100 mm)

歐/日系卡車柴油/機油濾芯扳手(90-100 mm)

- Drain the engine oil into suitable container and clean around the oil filter housing. Remove the filters, using filter tool A1481.
- OEM number:9996672
- 旋開油水分離器下部的放水閥放掉燃油。拔掉預熱插頭，再用濾清器扳手拆掉濾清器。
- 原廠號碼:9996672



H.C.B-C1481



H.C.B-F1481

編號ITEM NO.	尺寸SIZE(mm)	適用車種Application
A1481	100-110mm	VOLVO /HINO 6.5,7.5,8 (tons)機油濾芯 VOLVO/ HINO 6.5,7.5,8 (tons)OIL FILTER RENAULT (450) 機油濾芯 RENAULT (450) OIL FILTER SCANIA機油濾芯 SCANIA OIL FILTER
B1481	110-125 mm	FUSO 10.5-17(tons)機油濾芯 FUSO 10.5-17(tons) OIL FILTER
C1481	125-140 mm	MAN/SCANIA/DAF 四向閥乾燥濾芯 MAN/SCANIA/DAF Air Dryer Filter
D1481	70-80 mm	SCANIA柴油濾芯 SCANIA FUEL FILTER
E1481	80-90mm	TRUCK
F1481	90-100mm	FUSO (320) Oil Filter機油濾芯 FUSO (320) 機油濾芯 SCANIA (113) Oil Filter機油濾芯 SCANIA (113) 機油濾芯 SCANIA (114) Fuel Filter柴油濾芯 SCANIA (114) 柴油濾芯 SCANIA (SD) Transmission Filter變速箱濾芯 SCANIA (SD) 變速箱濾芯





通用卡車修護工具

General Truck Repair Tool



011

HWANG CHERNG BIN  
Specialty Tools Inc.



**H.C.B-A1502**

**20 TON AIR/HYDRAULIC FLOOR JACK - LOW PROFILE**

20 TON 氣動油壓千斤頂(超低型)



**INTENDED USE:**

Heavy duty truck, agricultural and heavy construction equipment. Ideal for loaded truck and trailer roadside service calls.

**Features**

- Long handle with 36-1/2" reach helps in positioning jack under vehicles with low overhang.
- May be stored in a vertical position.
- Hand grip also works as a stand to store the jack in a vertical position.
- Compact design fits easily between tandem wheels.
- Parkerized coating on pump piston, extension screw and extension adapters and chrome coated ram offer protection against rust.
- Removable extension screw is used with the two 4" extension adapters (included) for added height when necessary.
- Self-retracting ram eliminates manual lowering of the jack.
- 5 1/4" diameter high impact composite wheels make maneuverability easy.
- Fast efficient air pump reduces lifting time and has a built-in relief mechanism which prevents the jack from being used beyond its maximum capacity.
- Convenient push button air valve connected to an in-line filter prohibits contamination from entering the air/hydraulic system.

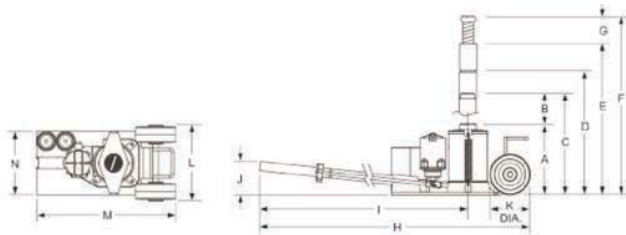

MODEL NUMBER	CAPACITY	PSI RANGE	A	B	C	D	E	F	G	H	I	J	K	L	M	N	SHIPPING WEIGHT (Lbs.)
A1502	20 TON	100-130	8.625"	4"	12.75"	16.75"	20.75"	22.75"	2.75"	53"	36.5"	6.25"	5.25"	9.25"	17.25"	7.75"	63

Low lift Height	High Lift Height	Stroke	Screw Extension	Base Size	P.S.I. Range	Shipping Weight
8.625	22.75	4"	2.75"	9.25" x 17.25"	100-130	63 lbs

General Truck Repair Tool



General Truck Repair Tool

**H.C.B-B1502** **20 TON AIR HYDRAULIC TRUCK JACK-LOW TYPE**

20 TON 氣動油壓千斤頂(超低型)

- Professional use in repairing heavy duty truck, agricultural and heavy construction equipment.
- Ideal for loaded truck and trailer roadside service.
- Compact low profile design for maximum access, fit easily and safely between wheels of a tandem axle vehicle.
- "T" handle allows jack operation at any handle position.
- Handle locking lever secures handle in either vertical, horizontal or 45 degree position.
- Self-retracting ram eliminates manual lowering of jack.
- Quick rated capacities life using air actuated operation.
- Automatic by-pass mechanism protects user and hydraulic cylinder from over pumping danger.
- Rust in hibitive coating on ram and extension screw.
- Extension screw gives added height when necessary.



Model	Capacity (Ton)	Stroke (mm)	Min. Height (mm)	Max. Height (mm)	Ext. Bar(A)mm	Ext. Bar(B)mm	Ext. Bar(C) mm	L x W x H (mm)	Weight (kgs)
B1502	20	90	190	280	15	40	60	570x140x1100	29

**H.C.B-C1502** **50 TON AIR/HYDRAULIC JACK**

50 TON 氣動/油壓千斤頂

- Low profile design for most of industrial applications.
- Forging base as the strongest construction to catch the needs in industry market.
- Housing welding onto the forged base makes to be free of leakage problem as well.
- Telescopic design of C1502 reaches the extra needed during
- Operating to save time and labor cost much.
- The equipped with two large Dia. Rubber wheels provide the greatest convenience and mobility you need.
- Air / Hydraulic design make you free pumping handle also with the most efficiency and time saving.





通用卡車修護工具

General Truck Repair Tool



011

HWANG CHERNG BIN  
Specialty Tools Inc.



## H.C.B-A1538

### EXTRA LONG HEXAGON IMPACT WHEEL NUTS SOCKET (DR. 3/4" ,24/27/30/32/33/36 mm,L:400 mm)

氣動長套筒(DR. 3/4" , 24/27/30/32/33/36 MM,L: 400 mm)

- Phosphate finish
- Chrome molybdenum
- Use for remover wheel nuts.
- 材質: 鉻鉬鋼
- 此工具用於拆卸車輪螺母



Parts No.	Size	L(mm)	D1/D2(mm)
A1538-24	24	400	18/38.8
A1538-27	27	400	20/42.5
A1538-30	30	400	22/46.3
A1538-32	32	400	23/48.8
A1538-33	33	400	23/49.8
A1538-36	36	400	26/53.8

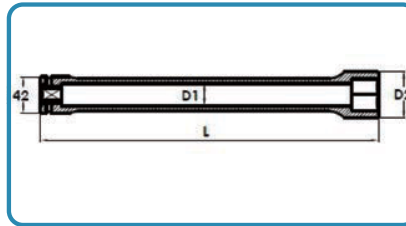

## H.C.B-A1560

### SCANIA 113 (320) TRUCK FRONT WHEEL AXLE BEARING PULLER

SCANIA 113(320)卡車前輪軸培林拔卸器

- This tool has two accessories of bearing block. When using different accessory, it can use on SCANIA 113 (320) trucks. It can save your time and labor when you remove the bearing from the front shaft axle.
- 此工具有兩種培林套座配件，可依照不同需求，使用在歐系車上，使用此工具，讓您在拔除培林時，更省時、省力。



## H.C.B-B1560

### TRUCK FRONT WHEEL AXLE BEARING PULLER (JAPANESE TRUCK)

卡車前輪軸培林拔卸器(日系車種)

- This tool has three accessories of bearing block. When using different accessory, it can use on Japanese trucks. It can save your time and labor when you remove the bearing from the front shaft axle.
- 此工具有三種培林套座配件，可依照不同需求，使用在日系車上，使用此工具，讓您在拔除培林時，更省時、省力。



VIDEO







011

HWANG CHERNG BIN  
Specialty Tools Inc.

通用卡車修護工具

General Truck Repair Tool



General Truck  
Repair Tool

### H.C.B-C1560

### TRUCK FRONT WHEEL AXLE BEARING PULLER TOOL (SCANIA/JAPANESE TRUCK)

卡車前輪培林拆卸器 (SCANIA/日系車種)

- This tool has five accessories of bearing block. When using different accessory, it can use on European and Japanese trucks. It can save your time and labor when you remove the bearing from the front shaft axle.
- 此工具有五種培林套座配件，可依照不同需求，使用在歐系與日系車上，使用此工具，讓您在拔除培林時，更省時、省力。



編號	車系	培林編號	適用車種
5	歐系	T2EE060	SCAINA 13(320)小軸
6		BT1-0554A (32312)	SCAINA 113(320)大軸
7	日系	32313JR	HINO15 ton以上 ISUZU大15 ton以上 UD 520 380
8		ET-CR-1355 ET-CR-1364	FUSO 15-35 ton 320 350
9		ET-CR-1555	FUSO 330 355
10 (選購配件)		3031-OJR	HINO 8.8~11 ton
11 (選購配件)		55KW02	FUSO 11 ton

### H.C.B-D1560

### TRUCK REAR WHEEL AXLE BEARING PULLER (JAPANESE TRUCK)

卡車後輪軸培林拆卸器 (日系車種)

- This tool is used for the extraction of the flank bearing of rear wheel axle of Japanese truck.
- Application: HINO, UD, ISUZU, FUSO (Over 17 tons)
- 說明:此工具用來拔除日系卡車後輪軸內側培林
- 適用車種: HINO, UD, ISUZU, FUSO 17噸以上卡車



VIDEO



H.C.B-E1560

NEW

SCANIA (113/114), MAN (410/414) TRUCK DIFFERENTIAL BEARING EXTRACTOR

SCANIA (113/114), MAN (410/414) 卡車差速器培林拆卸器

- Instruction: Normally, the removal of bearing is done by cutting, but it'll cause the damage of main shaft. Using this tool kit can makes the removal of bearing done quickly, safely, and prevents the bearing from damage.
- Applications: SCANIA (113/114), MAN (410/414)
- 說明: 傳統使用切割的方式拔除培林, 易損壞到主軸。使用此工具在拔除差速器的培林, 能快速、安全, 並保持培林不受損壞。
- 適用車種: SCANIA (113/114)(R770/R780), MAN (410/414)

VIDEO



Differential gear main shaft bearing



Bearing OEM No.: 543 562

H.C.B-A2258

TOE JACK

L 型油壓千斤頂

- Heat treated & chrome plated hydraulic rod provide longer seal life and optimum performance.
- Internal safety valve prevents toe jack being used behind its rated capacity.
- Housing welding onto the forged base makes to be free of leakage problem.
- Removable handle saves the handle force during operation.
- High strength Toe-Lift in tight clearances.
- Swivel sockets for easy operation.
- Use the safe dependable toe jacks and speed rollers to safely lift and move a heavy load in a low clearance situation.
- Super low height (the lowest in the industry) toe jacks, ease operation under the most difficult situations.
- These are the best choice for lifting heavy machinery and cargo, especially when installing industrial machinery.
- Relocating shipyard equipment, or during bridge and plant construction.

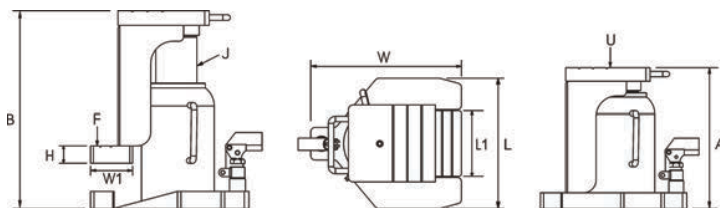

Item	TOP CAP.	TOP-LIFT CAP.	TOE-LIFT STROKE	MIN.	MAX.	PISTON ROD DIA.	BASE	HEIGHT	TOP-LIFT	WEIGHT
	U(Tons)	F(Tons)		HEIGHT	HEIGHT		DIMENSIONS			
			(mm)	A(mm)	B(mm)	J(mm)	LxW(mm)			
A2258-025	2.5	1.2	70	194	294	19	140 X 190	19	65 X 50	6.5
A2258-040	4	2	80	204	314	25	150 X 200	19	65 X 50	8.2
A2258-060	6	3	80	212	322	36	160 X 217	19	65 X 50	10
A2258-100	10	5	100	258	388	40	189 X 242	22	75 X 55	16.9
A2258-160	16	8	100	275	406	52	211 X 256	25	90 X 55	24.9
A2258-200	20	10	90	303	443	56	228 X 274	25	100 X 60	33
A2258-300	30	15	80	322	469	70	259 X 305	32	110 X 60	52
A2258-500	50	25	80	333	481	90	299 X 347	38	150 X 60	81

**H.C.B-A2273**
**TRUCK CLUTCH AND FLYWHEEL JACK-LOW CLEARANCE**

卡車離合器/飛輪千斤頂

- To remove, install and transport (in the lowered position) both 14" & 15-1/2" heavy duty clutches and flywheel.
- Clutch removal and installation becomes a one-man job.
- Adjustment bolt on saddle aligns clutch.
- Spline shaft rotates 360 degrees, turns left and right for clutch and engine alignment. 2" and 1-3/4" spline shafts included.
- Conveniently located release valve and 360 degree rotating pump handle allow jack to be operated in any work position.
- 用來拆卸和安裝和運輸 (在較低的位置) · 這兩個14"及15-1/2"重型離合器和飛輪。
- 離合器的拆卸和安裝只需要一個人工作即可。
- 在調整螺栓對齊離合器。
- 軸旋轉360度 · 轉左、右離合器和發動機對齊。2"和1-3/4"軸包含在內。
- 便利釋放閥和360度旋轉幫浦手柄使千斤頂在任何工位進行操作。

**H.C.B-A2280**
**UNIVERSAL JOINT (Dr. 1")**

1"萬向轉接頭

- Drop-forged steel universal joint.
- Suitable for use on all types of air impact tool.
- Chrome Molybdenum steel with phosphate finish for added corrosion resistance.
- Spring-ball socket retainer and drilled head to accept retaining pin.
- 落鍛萬向轉接頭。
- 適用於所有氣動工具。
- 鉻鉬鋼 · 用磷酸鹽光潔度以增加耐腐蝕性。

**H.C.B-A2281**
**Dr. 3/4" IMPACT SOCKET KIT (17 PCS)**  
 (19/21/22/24/27/30/32/33/34/35/36/38/40/41/46/50/55 mm)

 Dr. 3/4" 氣動套筒組(17 PCS)  
 (19/21/22/24/27/30/32/33/34/35/36/38/40/41/46/50/55 mm)

- Material Surface Finish: CR-MO, Black phosphate
- Size:  
19/21/22/24/27/30/32/33/34/35/36/38/40/41/46/50/55 mm
- 表面處理: CR-MO
- 尺寸:  
19/21/22/24/27/30/32/33/34/35/36/38/40/41/46/50/55 mm







通用卡車修護工具

General Truck Repair Tool



011

HWANG CHERNG BIN  
Specialty Tools Inc.



## H.C.B-A2282

## TRUCK BRAKE SPOONS (2 PCS)

卡車剎車調整扳手(2 PCS)

- Full length: 16/18\*200 mm, 18\*200 mm
- Designed to adjust brakes on most cars and light trucks.
- Universal angle design for most cars.

- 全長: 16/18\*200 mm, 18\*200 mm
- 此工具設計用來調整一般車及輕型卡車剎車
- 萬用角度設計可用於大部分的車種



## H.C.B-C2297

**NEW**

## DIESEL/PETROL FUEL SYRINGE (1.5 L)

柴/汽油真空抽取注射器 (1.5 升)

- 1.5 liters
- Designed for both petrol and diesel vehicles, to retrieve excess fuel from fuel lines before maintenance.
- Eliminates the risk of fuel spills and damage to pipes, if clamped.
- Connectors for PSA/Vauxhall/Opel vehicles and two universal connectors for older cars.

- Prevents spillage
- Adaptor Universal

- 容量: 1.5 升
- 此注射器適用於汽柴油車種。於維修前，可將油管內多餘的油抽出。
- 此注射器具特殊設計可防油料溢出且不會損傷油管。
- 配有PSA/Vauxhall/Opel 車種的接頭及兩種廣用接頭可適用於舊式車種。
- 廣用型轉接頭



## H.C.B-A2299

**NEW**

## 3 FUNCTION TIRE PRESSURE GAUGE(FOR TRUCK)

三用胎壓量錶(卡車)

- The professional choice of dial pressure gauge for quick, clear and accurate readings.
- 此工具為專業壓力表，可以快速、清晰的測出胎壓



**H.C.B-A2300**
**NEW**
**FLEXIBLE CROW'S FOOT SOCKET WRENCH KIT (12 PCS)**

搖頭鴨掌扳手組 (12 PCS)

- 3/8" square drive rotatable head wrenches
- Sizes: 8, 9, 10, 11, 12, 13, 14, 15, 16, 17, 18 & 19 mm
- Rotatable head which can rotate 230 degrees
- Traditional flare nut wrench with crowfoot function.
- Used with F-bar, H-bar, T-bar, speed-handle
- A rotatable crowfoot wrench can be used in hard-to-reach areas with the limit of 110 degrees
- Suitable for all hydraulic, fuel, oil brake, A/C, O2 sensor and air line work



- Dr. 3/8" 的活動扳手
- 尺寸: 8, 9, 10, 11, 12, 13, 14, 15, 16, 17, 18 & 19 mm
- 旋轉角度可達230度
- 結合傳統的錐型扳手及鴨掌扳手的功能
- 結合F型,H型,T型的搖頭鴨掌扳手
- 使用搖頭鴨掌扳手時, 可使用在一般扳手難以使用的地方, 其中角度可達110度
- 適用於所有的油壓、氣油、剎車油、冷氣、氧氣感應器和航空作業



**H.C.B-A2301**
**NEW**
**75° BOX END & FLEXIBLE GEAR RATCHET WRENCH WITH GO-THROUGH SOCKET KIT (17 PCS)**

穿透式套筒組 (17 PCS)

- Specification:
- 1PCS - 20 mm 75° Box end & flexible gear ratchet wrench with go-through socket wrench handle
- 1PCS - 20 mm x 75 mm (L) Go-through extension bar
- 12PCS - Go-through sockets: 8, 9, 10, 11, 12, 13, 14, 15, 16, 17, 18 & 19 mm
- 1PCS - 20 mm x 1/4" Socket adaptor
- 1PCS - 20 mm x 3/8" Socket adaptor
- 1PCS - 20 mm x 1/2" Socket adaptor

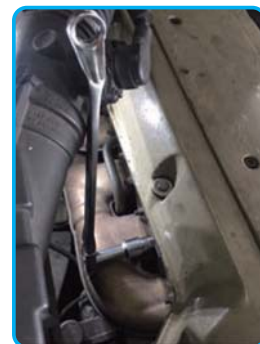

- 規格
- 1PCS - 20 mm 尾端具有75度穿透式扳手的可轉動式棘輪扳手。
- 1PCS - 20 mm x 75 mm (L) 穿透式延長桿
- 12PCS - 穿透式套筒: 8, 9, 10, 11, 12, 13, 14, 15, 16, 17, 18 & 19 mm
- 1PCS - 20 mm x 1/4" 套筒接頭
- 1PCS - 20 mm x 3/8" 套筒接頭
- 1PCS - 20 mm x 1/2" 套筒接頭





通用卡車修護工具

General Truck Repair Tool



011

HWANG CHERNG BIN  
Specialty Tools Inc.



## H.C.B-A2302

**NEW**

## DOUBLE FLEXIBLE RATCHET FLARE NUT WRENCH (10 x 12 / 13 x 14 / 15 x 17 mm) (3 PCS)

雙搖頭開口油管扳手(10 x 12 / 13 x 14 / 15 x 17 mm) (3 PCS)



- This product is upgraded version of a traditional long pipe wrench which becomes a ratchet pipe wrench that can be used in the brake line, and the small space such as small-angle ABS, EBD, EBC, ESP, etc. In active safety technology.
  - The head of this wrench can rotate 180 degrees.
  - Color marking buckles, red is forward, black is reversal.
  - Car: This size is a common size, which is suitable for various types of vehicles.
  - The size of brake systems: 8/10/11/12; The fuel lines with the size: 13/14/15/17
  - Mid-size species, large vehicles will become larger.
- 此產品有別於一般傳統的長的扳手，新型的棘輪扳手可以使在於煞車線與空間較小的地方。例如角度較小的ABS、EBD、EBC、ESP等主動安全系統
  - 扳手前端可180度旋轉
  - 使用顏色進行辨識，紅色為順時針旋轉，黑色為逆時針旋轉
  - 煞車系統的尺寸為8/10/11/12; 氣油管線的尺寸為13/14/15/17
  - 可適用於中型與大型車種



## H.C.B-A2306

**NEW**

## DR. 3/4" TORQUE WRENCH (200-1000 N.M)

DR. 3/4" 扭力扳手 (200-1000牛頓米)



- Industrial application.
  - Wide range of choice.
  - Tolerance of torque  $\pm 3\%$ .
  - Easy torque-adjusting design brings energy-saving benefit.
  - Applied to both clockwise and counterclockwise directions.
  - Quality meets DIN ISO 6789 & ASME B107.300-2010.
- 可應用在工業範圍
  - 可選擇的範圍寬廣
  - 扭力誤差值:  $\pm 3\%$
  - 簡易好操作的設計為你節省時間
  - 可順時針使用也可逆時針使用
  - 品質符合DIN ISO 6789 & ASME B107.300-2010.





011

HWANG CHERNG BIN  
Specialty Tools Inc.

通用卡車修護工具

General Truck Repair Tool



General Truck  
Repair Tool

## H.C.B-A2307

NEW

### RATCHET EXHAUST PIPE CUTTER

排氣管切管器

- Universal application pipe cutter designed for where access is restricted.
- Ratchet mechanism allows cutting without having to rotate the tool completely around the tubing.
- Suitable for the toughest materials including stainless steel exhaust pipes.
- Contents : 1" 7/32→2" 9/16", 31-65 mm, thickness ≤ 3 mm
- 通用型的切管設計
- 棘輪式的切管設計讓切割時不用繞著管線旋轉即可輕鬆切管
- 適用在難以切割的材質，包括不銹鋼排氣管



## H.C.B-A2309

NEW

### 3L TRUCK/ TRAILER WHEEL AXLE OIL DRAIN

3L卡車/拖車輪軸油盤

- Contents:  
Capacity: 3 L (107 oz)  
Weight: 380 – 400 g  
Dimension of product: 316 (L) × 246 (D) × 156 (H) mm
- Features & Benefits:  
■ Ideal for using during truck & trailer wheel repair
- It has features like easy pour evacuation mouth & ergonomic handles with storage capability for hub nuts
- Used to catch oil from wheel hubs after removing cap
- 規格  
容量: 3升 (107盎司)  
Weight: 380 – 400 g  
尺寸: 316 (長度) × 246 (深度) × 156 (高度) mm
- 此為卡車及拖車輪胎維修的理想工具。
- 具有可以輕鬆傾倒排油的開口設計及符合人體工學且具收納輪殼螺帽設計的把手。
- 在移除輪圈蓋後，此油盤可以用來接收從輪殼流下來的油。



## H.C.B-A2310

NEW

### OIL DRAIN PAN

油盤

Features & Benefits:

- This Oil Drain Pan includes easy grip, large carrying handles and integral spout for pouring waste oil or fluids into a recycling container.
- The anti-splash lip prevents spillage. Ideal for draining antifreeze or oil.

※Not suitable for spray gun cleaner

特色 & 優點:

- 此油盤擁有方便、好拿取的大提把和方便傾倒廢油、廢液的集中型漏斗嘴。
- 漏斗嘴有防潑濺設計，可避免液體溢出，是用來收集防凍劑或廢油的理想容器。

※請勿使用噴槍清洗

Contents:

Item no.	Capacity	Weight	Dimension of product
A2310-035	3.5 L	284 g	410 (L) × 330 (D) × 100 (H) mm
A2310-080	8 L	566 g	502 (L) × 400 (D) × 132 (H) mm
A2310-160	16 L	952 g	582 (L) × 472 (D) × 156 (H) mm





SINCE 1990

HWANG CHERNG BIN  
Specialty Tools Inc.



# 氣動工具

AIR TOOL







011

HWANG CHERNG BIN  
Specialty Tools Inc.

氣動工具

Air Power Tools



## H.C.B-A2005

### 1/2" AIR IMPACT WRENCH

1/2" 氣動扳手(下排式)

- Specification / 規格 :  
 Square drive (方榫)-----1/2" (12.7 mm)  
 Free speed (無載轉速)-----6000 rpm  
 Max torque (最大扭力)-----420 ft-lbs (570 Nm) / 570 (牛頓·米)  
 Air inlet (進氣口)-----1/4" NPT (6.35 mm)  
 Weight (重量)-----6 lbs (2.7 kgs)  
 Overall length (總長)-----7.4" (188 mm)



## H.C.B-A2005-1

### 1/2" AIR IMPACT WRENCH (WITH 10 PCS SOCKET)

1/2" 氣動扳手(下排式, 含套筒)

- Specification of air ratchet wrench / 氣動扳手規格 :  
 Square drive (方榫)-----1/2" (12.7 mm)  
 Free speed (無載轉速)-----6000 rpm  
 Max torque (最大扭力)-----420 ft-lbs (570 Nm) / 570 (牛頓·米)  
 Air inlet (進氣口)-----1/4" NPT (6.35 mm)  
 Weight (重量)-----6 lbs (2.7 kgs)  
 Overall length (總長)-----7.4" (188 mm)
- Specification of socket / 套筒尺寸 :  
 1: 27 mm    6: 17 mm  
 2: 24 mm    7: 14 mm  
 3: 22 mm    8: 13 mm  
 4: 21 mm    9: 12 mm  
 5: 19 mm    10: 10 mm
- N.W. / 淨重 : 4.22 kgs



## H.C.B-B2025

### 3/8" AIR MINI RATCHET WRENCH

3分氣動棘輪扳手

- Specification / 規格 :  
 Free Speed (轉速) ----- 240 RPM  
 Max. Torque (最大扭力) -- 18呎-磅 (ft-lbs)  
 Net Weight (淨重) ----- 0.6 kg  
 Overall Length (全長) ---- 178 mm  
 Air Inlet (進氣口規格) -----1/4"  
 Hose Size (風管規格) -----3/8"







### H.C.B-A2034

### 1/4" 90° AIR STUBBY AIR RATCHET WRENCH

1/4" 90° 氣動扳手

- Specification / 規格 :
  - Square drive (方榫)-----1/4"
  - Free speed (無載轉速)-----240 rpm
  - Max torque (最大扭力)-----18 ft-lbs
  - Air inlet (進氣口)-----1/4" NPT
  - Air pressure bar (空壓)-----90 psi
  - Air consumption (耗氣量)---- 3 CFM
  - Weight (重量)-----1.1 lbs (0.55 kgs)
  - Overall length (總長)-----6-5/16"



### H.C.B-A2046

### 1/2" 90° STUBBY AIR RATCHET WRENCH

1/2" 90° 氣動扳手

- Specification / 規格 :
  - Square drive (方榫)----- 1/2"
  - Free speed (無載轉速)-----150 rpm
  - Max torque (最大扭力)-----60 ft-lbs
  - Air inlet (進氣口)-----1/4" NPT
  - Weight (重量)-----2.86 lbs (1.3 kgs)
  - Overall length (總長)-----10" (254 mm)



### H.C.B-A2047

### AIR DIE GRINDER

氣動刻模機



### H.C.B-A2048

### 16 PCS AIR DIE GRINDER KIT

氣動刻模機組 (16 PCS)





Air Power Tools

**H.C.B-A2139**
**1/2" MINI IMPACT WRENCH**

1/2" 輕型氣動扳手

## ■ Specification / 規格：

- Square drive (方榫) -----1/2"
- Bolt size (螺栓能力) ----- 14 mm
- Free speed (無載轉速) -----12500 rpm
- Max torque (最大扭力) -----300 ft-lbs
- Overall length (總長) ----- 145 mm
- Air inlet (進氣口) ----- 1/4" NPT
- Hose (氣管) -----3/8"
- Weight (重量) -----1.5 kgs

Item	SQ.	Bolt Size	Speed	Torque	Length
H.C.B-A2139	1/2"	14mm	12500	300ft/lb	145mm

Item	Inlet	Hose	CFM	L/Min	Weight
H.C.B-A2139	1/4"	3/8"	3	85	1.50kg

**H.C.B-A2173**
**1/2" 90° AIR RATCHET WRENCH**

1/2" 90° 氣動棘輪扳手

## ■ Specification / 規格：

- Square drive (方榫) -----1/2"
- Free speed (無載轉速) -----160 rpm
- Max torque (最大扭力) -----55 ft-lbs (7.6 kg·m)
- Air inlet (進氣口) -----1/4" NPT
- Air consumption (耗氣量) --- 3 CFM (L/min)
- Overall length (總長) -----9-3/8" (238 mm)
- Weight (重量) -----2.52 lbs (1.14 kgs)

**H.C.B-A2200**
**3/4" IMPACT WRENCH**

3/4" 氣動扳手

## ■ Specification / 規格：

- Square drive (方榫) -----3/4" (19 mm)
- Free speed (無載轉速) -----5000 rpm
- Max torque (最大扭力) ----- 1250 ft-lbs (1695 Nm) / 1695 牛頓·米
- Bolt Capacity (螺栓能力) ----- 1-1/4" (32 mm)
- Net weight (淨重) ----- 9.6 lbs (4.3 kgs)
- Overall length (總長) -----8.5" (217 mm)
- Avg. Air consumption (平均耗氣量) --- 3 CFM (L/min)
- Air inlet (進氣口) ----- 3/8" NPT
- Air pressure bar (空壓) ----- 90 psi (6.3 kg/cm<sup>2</sup>)
- Sound level (音壓) -----96 dBA

**VIDEO**

**H.C.B-B2200**
**NEW**
**3/4" ALUMINUM HOUSING IMPACT WRENCH**

3/4" 鋁合金氣動扳手

## ■ Specification:

- Free speed(轉速) -----5,800 rpm
- Max.torque @ 90 psi(最大扭力)-----1,750 ft-lb/ 2373 nm
- Net weight(淨重) -----13.50 lbs (6.10kgs)
- Overall length(全長)----- 228 mm (9.0 inch)
- Air inlet(進氣孔規格) ----- 3/8 inch
- Air hose id(風管規格) -----1/2 inch
- Average.Air consumption (耗氣量) -----227 l/min
- Lpa (聲壓)-----105 db (a)
- Work pressure (工作壓力) -----90 psi





## H.C.B-A2285

### 1/2" MINI COMPOSITE IMPACT WRENCH (JAMBO HAMMER)

4分塑膠手柄迷你單環捶打式衝擊扳手

- Specification / 規格 :
  - Free Speed (轉速) ----- 9,500 RPM
  - Max. Torque (最大扭力) -- 500呎-磅 (ft-lbs), 678 Nm
  - Net Weight (淨重) ----- 1.15 kg
  - Overall Length (全長) ---- 112 mm
  - Air Inlet (進氣口規格) ----- 1/4"
  - Hose Size (風管規格) ----- 3/8"



## H.C.B-A2286

### 1/2" COMPOSITE IMPACT WRENCH (TWIN HAMMER)

4分塑膠手柄雙環捶打式衝擊扳手

- Specification / 規格 :
  - Free Speed (轉速) ----- 7,300 RPM
  - Max. Torque (最大扭力) -- 800呎-磅 (ft-lbs), 1,085 Nm
  - Net Weight (淨重) ----- 2.0 kg
  - Overall Length (全長) ---- 175 mm
  - Air Inlet (進氣口規格) ----- 1/4"
  - Hose Size (風管規格) ----- 3/8"



## H.C.B-B2286

### 3/8" COMPOSITE IMPACT WRENCH (TWIN HAMMER) 475 NM

3分塑膠手柄雙環捶打式衝擊扳手(扭力475牛頓米)

- Specification / 規格 :
  - Free Speed (轉速) ----- 10,500 RPM
  - Max. Torque (最大扭力) -- 450呎-磅 (ft-lbs), 610 Nm
  - Net Weight (淨重) ----- 1.29 kg
  - Overall Length (全長) ---- 150 mm
  - Air Inlet (進氣口規格) ----- 1/4"
  - Hose Size (風管規格) ----- 3/8"



## H.C.B-A2287

### 3/4" COMPOSITE IMPACT WRENCH (TWIN HAMMER)

6分塑膠手柄雙環捶打式衝擊扳手

- Specification / 規格 :
  - Free Speed (轉速) ----- 7,300 RPM
  - Max. Torque (最大扭力) -- 1,400呎-磅 (ft-lbs), 1,898 Nm
  - Net Weight (淨重) ----- 3.3 kg
  - Overall Length (全長) ---- 202 mm
  - Air Inlet (進氣口規格) ----- 3/8"
  - Hose Size (風管規格) ----- 1/2"







**H.C.B-A3036**
**AIR HYDRAULIC PUMP (1600 c.c.) (Dr.3/8" ADAPTOR)**

氣動幫浦 (1600 c.c.) (3/8"接頭)

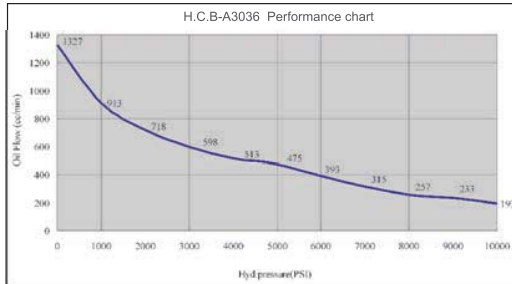
- Application: 10~30 tons ■ 適用範圍: 10~30噸
- 接頭尺寸: 3/8" NPT x 1.5M x 3/8" NPT



Sound level test	80 dba/m
N.W.	8.32 KGS
G.W.	8.5 KGS
CUFT	0.8'
Oil reservoir capacity	1600 c.c.
Hyd. pressure (PSI)	0 1000 2000 3000 4000 5000 6000 7000 8000 9000 10000
Oil flow (c.c./min)	1327 913 718 598 513 475 393 315 257 233 193

**H.C.B-B3036**
**AIR HYDRAULIC PUMP (1800 c.c.)**

氣動幫浦 (1800 c.c.)

- Application: 10~30 tons ■ 適用範圍: 10~30噸



Hyd. pressure (PSI)	0 1000 2000 3000 4000 5000 6000 7000 8000 9000 10000						
Oil flow (c.c./min)	1170 970 850 700 600 515 440 370 315 250 195						
Model Number	Oil Capacity (c.c.)	Pressure Rating (psi)	Air Pressure Range (kg/cm <sup>2</sup> )	Dimensions L*W*H(mm)	Sound Level Test (dba/m)	N.W. (Kgs)	G.W. (Kgs)
H.C.B-B3036	1800	10000	7~10	310*144*208.5	80	10.2	10.7

**H.C.B-C3036**
**DOUBLE HOSE AIR HYDRAULIC PUMP (3800 c.c.)**

雙管幫浦 (3800 c.c.)

- Oil reservoir capacity: 3800 c.c. ■ 儲油量: 3800 c.c.

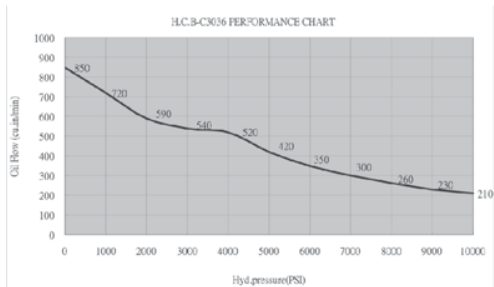

Pressure (psi)	0 1000 2000 3000 4000 5000 6000 7000 8000 9000 10000							
Oil Flow (c.c./min)	850 720 590 540 520 420 350 300 260 230 210							
Item no.	Oil Capacity (c.c.)	Pressure Rating (psi)	Air Pressure Range (kg/cm <sup>2</sup> )	Dimensions L*W*H(mm)	Sound Level Test (dba/m)	N.W. (Kgs)	G.W. (Kgs)	CUFT
H.C.B-C3036	3800	10000	7~10	470*147*210	80	11.6	12.6	1

**H.C.B-D3036**
**AIR / HYDRAULIC PUMP (7600 c.c.)**

氣動 / 油壓幫浦 (7600 c.c.)

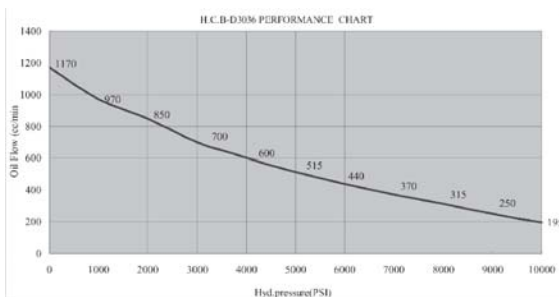

inflow 1/4"-18NPT      outflow 3/8"-18NPT



Pressure (psi)	0 1000 2000 3000 4000 5000 6000 7000 8000 9000 10000							
Oil Flow (c.c./min)	1170 970 850 700 600 515 440 370 315 250 195							
Item no.	Oil Capacity (c.c.)	Pressure Rating (psi)	Air Pressure Range (kg/cm <sup>2</sup> )	Dimensions L*W*H(mm)	Sound Level Test (dba/m)	N.W. (Kgs)	G.W. (Kgs)	CUFT
H.C.B-D3036	7600	10000	7~10	352*269*250	80	22	23	1



### H.C.B-E3036

### AIR / HYDRAULIC FOOT PUMP (2,000 c.c.)

氣動/油壓幫浦(2000 c.c.)



**Intended use:**

For automotive / truck, industrial & construction jobs.  
The added convenience of an air motor reduces pumping time and effort to activate cylinders.

**Features**

- Designed to utilize exhaust air to help power the pump, requiring only 80 p.s.i. air pressure to develop 10,000 p.s.i. hydraulic pressure.
- Air exhaust muffler for quieter operation.
- Air and oil inlet filters for reduced risk of damage from contamination.
- Designed with durable light weight, corrosion resistant plastics.
- Foot pedal provides hands free pumping and release of load.
- Designed to be used with a single-acting cylinder.
- Internal pressure relief valve for overload protection.
- Equipped with a more durable aluminum reservoir.
- Comes with two different size poppit valves that can be quickly and easily installed. Poppit valves reduce the return flow of oil back to the pump's reservoir providing a safer controlled lowering of load.

MODEL NUMBER	HYDRAULIC PRESSURE RATING (P.S.I.)	USABLE OIL CAP. (Cu. In.)	OUTPUT FLOW RATE (Cu. In. Per Min.)		AIR PRESSURE RANGE (P.S.I.)	AIR CONSUMPTION (scfm)	VALVE FUNCTION	SOUND LEVEL (dBA)	THREAD CONNECTIONS		DIMENSIONS (Inches)			WEIGHT (Lbs.)
			No Load	Load					AIR (NPT)	HYDRAULIC (NPT)	Length	Width	Height	
E3036	2,000	122	80.5	12.8	40-170	24	Advance / Hold / Retract	85	.25"-18	.375"-18	12.5	5.75	8	22

### H.C.B-F3036

**NEW**

### AIR/HYDRAULIC PUMP (WITHOUT HOSE) 6.2-6.8 BAR AIR PRESSURE / PUMP230-245 BAR

氣動/油壓幫浦(不含管)



**INTENDED USE:**

- For automotive, truck, industrial & construction jobs.  
The added convenience of an air motor reduces pumping time and effort to activate cylinders.

**Features:**

- Designed with durable light weight, corrosion resistant plastics.
- Equipped with a more durable aluminum reservoir.

**應用範圍:**

- 可使用在車上·卡車·工業或建築上  
氣動的馬達可加快幫浦作動的時間·使用上更有效率

**特色:**

- 使用重量輕·抗腐蝕的塑膠設計
- 配有更耐用的鋁製儲油區



011

HWANG CHERNG BIN  
Specialty Tools Inc.

氣動工具

Air Power Tools



Air Power Tools

## H.C.B-A2269

### 1" SQ DR. HEAVY DUTY IMPACT WRENCH

1" 氣動扳手

■ Specification:

- Drive Size-----1"Sq
- Free Speed----- 3000 rpm
- Working Max Torque@5sec---- 3390 Nm (2500 ft-lb)
- Overall Length ----- 436mm (17.2 inch)
- Air Inlet-----1/2 inch
- Air Hose ID -----3/4 inch
- Average. Air Consumption-----411 L/min
- Net Weight-----34.84 lb (15.8 KGS)



## H.C.B-A2270

### 1" SQ DR. EXTRA HEAVY DUTY IMPACT WRENCH, LONG ANVIL

1" 長軸氣動扳手

■ Specification:

- Drive Size-----1"Sq
- Free Speed----- 3000 rpm
- Working Max Torque@5sec---- 3390 Nm (2500 ft-lb)
- Overall Length ----- 634mm (25 inch)
- Air Inlet-----1/2 inch
- Air Hose ID -----3/4 inch
- Average. Air Consumption-----411 L/min
- Net Weight-----37.04 lb (16.8 KGS)



VIDEO

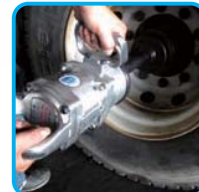







011

HWANG CHERNG BIN  
Specialty Tools Inc.

一般修護工具修護設備

General Repair Equipment



General Repair Equipment

## H.C.B-A1073

## 3-SHELF SERVICE CART (STAINLESS)

三層不銹鋼工具車

- Thickness: 1.5 mm
- Size: 1050 x 400 x 780 mm
- The open up tool cart to place repair tools.
- 厚度 : 1.5 mm
- 尺寸 : 1050 x 400 x 780 mm
- 開放式的工具車



## H.C.B-C1076

## 11 DRAWER ROLLER CABINET

11抽工具車

- Product Dimension:  
OVERALL : 660 mm (W) x 307 mm (D) x 374 mm (H)  
3 DRAWERS : 170 mm (W) x 275 mm (D) x 50 mm (H)  
2 DRAWERS : 569 mm (W) x 275 mm (D) x 50 mm (H)  
1 DRAWER : 569 mm (W) x 275 mm (D) x 75 mm (H)  
N.W. : 25.4 KGS G.W. : 28.4 KGS CUFT : 3.97'
- Top - : 660 mm (W) x 307 mm (D) x 251 mm (H)  
2 DRAWERS : 569 mm (W) x 275 mm (D) x 50 mm (H)  
1 DRAWER : 569 mm (W) x 275 mm (D) x 75 mm (H)  
N.W. : 13 KGS G.W. : 15.5 KGS CUFT : 2.7'
- Bottom - : 670 mm (W) x 460 mm (D) x 812 mm (H)  
OVERALL WITH 5" CASTERS :  
670 mm (W) x 460 mm (D) x 960 mm (H)  
5 DRAWERS : 576 mm (W) x 380 mm (D) x 75 mm (H)  
2 DRAWERS : 576 mm (W) x 380 mm (D) x 154 mm (H)  
N.W. : 64 KGS G.W.:72 KGS CUFT : 12.24'







一般修護工具修護設備

General Repair Equipment



011

HWANG CHERNG BIN  
Specialty Tools Inc.



## H.C.B-A1135-R

## THE COMPACT TOOLBOX TROLLEY (RED)

美式工具車

- OVERALL : 780 mm (W) x 520 mm (D) x 890 mm (H)
- OVERALL WITH 4" CASTERS :  
780 mm (W) x 520 mm (D) x 1020 mm (H)
- 2 DRAWERS : 298 mm (W) x 445 mm (D) x 81 mm (H)
- 1 DRAWER : 628 mm (W) x 445 mm (D) x 81 mm (H)
- 1 DRAWER : 628 mm (W) x 445 mm (D) x 127 mm (H)
- (1) BALL BEARING SLIDE
- (2) 4"x11/4" CASTERS ( 2 SWIVEL + 2 SWIVEL W/BRAKE)



## H.C.B-A1541

## DIGITAL CALIPER

極速卡尺

- Measuring Range:  
0-6"/150 mm, 0-8"/200 mm, 0-12"/300 mm
- Resolution: 0.0005"/0.01 mm
- Accuracy:  
6"/150 mm:±0.001"/±0.02 mm, 12"/150 mm:±0.0015"/±0.04 mm
- 量測範圍 :  
0-6"/150 mm, 0-8"/200 mm, 0-12"/300 mm
- 解析度 : 0.0005"/0.01 mm
- 準確度 :  
6"/150 mm:±0.001"/±0.02 mm, 12"/150 mm:±0.0015"/±0.04 mm



## H.C.B-A2001

## 3-SHELF SERVICE CART

3層工具車

1 / 21.5 / 23.5 / 4.3'

- For garage, office, warehouse service.
- Two or three sturdy 2" deep trays with red enamel paint.
- 4 large 3" swivel casters and two with brakes device.
- Easy assembly and use.
- It is coming with 1 piece of tools holder.
- Capacity: 150 KGS
- Specification: W750 mm X D440 mm X H960 mm
- 適用於修車廠、辦公室和倉庫。
- 3層紅色烤漆2吋深的托盤。
- 4個3吋腳輪，其中2個附有煞車。
- 方便組裝與使用。
- 配備有工具架。
- 載重：150公斤
- 尺寸：750mm(寬) x 440mm(深) x 960mm(高)



(not include tools)



■ Delivery without tools





011

HWANG CHERNG BIN  
Specialty Tools Inc.

一般修護工具修護設備

General Repair Equipment



General Repair Equipment

## H.C.B-A2010

## FOUR-SHELF CART

工具車 (4層開放式附間隔塊)

- The open up tool cart to place repair tools.
- Specification:  
W550 mm X D480 mm X H900 mm
- 開放式的工具車
- 尺寸：550 mm(寬) x 480 mm(深) x 900 mm(高)



## H.C.B-A2011

## TOOL BOX, 6 DRAWERS (MODEL 300)

6抽工具車 (300型)

- The drawers are equipped with ball bearings to increase the carrying capacity.
- The drawers are equipped with ball bearings which make it convenient to take the drawers out
- Specification: W560 mm X D460 mm X H910 mm
- 配備滾珠培林抽屜的鐵櫃，可提高耐重量。
- 滾珠培林式的抽屜，方便將整個抽屜取出。
- 尺寸：560 mm(寬) x 460 mm(深) x 910 mm(高)





一般修護工具修護設備

General Repair Equipment



011

HWANG CHERNG BIN  
Specialty Tools Inc.



H.C.B-A2060

TOOL BOX, 7 DRAWERS ROLLER  
CART (BALL BEARING SLIDE)

H.C.B-B2060

WALL CABINET (W: 660 mm x D: 305 mm x H 600 mm)

H.C.B-C2060

TOP TRAY

H.C.B-D2060

( 18" ) SIDE PANEL



**H.C.B-A2060**  
TOOL BOX, 7 DRAWERS ROLLER  
CART (BALL BEARING SLIDE)  
7抽工具車

- Size (WxDxH): 26.3"x 18" x 32"  
(670x460x813 mm)
- 尺寸: 670 mm(寬) x 460 mm(深)  
x 813 mm(高)

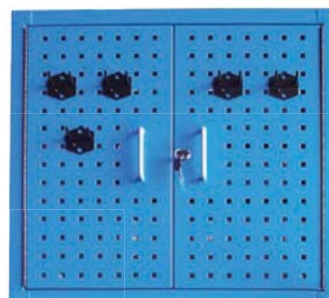
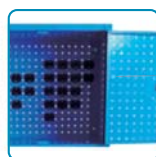

**H.C.B-B2060**  
WALL CABINET  
工具壁櫃

- Size: W: 660 mm x D: 305 mm x H 600 mm
- 尺寸: 寬: 660 mm x 深: 305 mm x 高: 600 mm



**H.C.B-D2060**  
(18") SIDE PANEL  
(18") 側板



**H.C.B-C2060**  
TOP TRAY  
上方膠盤

- Turn the top of your A2060 series roll cabinet into a work/storage bench with one of these heavy duty tray tops. Also protects the top of your roll cabinet. Features include: sturdy handles, a large tray area, screwdriver slots, front & side storage wells.
- 此膠盤放置壁櫃的上方，可保護壁櫃上方避免撞擊，並多出可利用空間。
- 特點：有堅固的手柄與大托盤，前方與側邊有凹槽可以擺放個人平常使用的小工具，使工具不易滑落。

- A2060系列工具車方便收納，其特點包括：堅固的手柄，一個大托盤區，螺絲刀槽，壁櫃可以吊掛工具及側邊可以吊掛擦手紙。



011

HWANG CHERNG BIN  
Specialty Tools Inc.

一般修護工具修護設備

General Repair Equipment



General Repair Equipment

## H.C.B-E2060

## 14 DRAWER ROLLER TOOL CABINETS

### 14抽滾輪工具櫃

- This sturdy tool storage cabinet consists of heavy duty ball bearing slides on all its drawers for smooth drawing.
- Features include key-locking drawers and 14,600 cu. in. storage.
- This tool storage cabinet includes four casters to easily move your tools around the shop making it the ideal tool storage cabinet for any garage or shop!

- 此工具車有偌大的儲存工具的抽屜，您可以依照自己所常用的工具來擺設
- 4個輪子讓你可輕鬆移動此工具車。
- 是你在車庫間的好幫手。
- 抽屜可上鎖，避免抽屜因搖晃而散落。



## H.C.B-F2060

**NEW**

## 3 DRAWER DOUBLE SIDED TOOL TROLLEY

### 3抽雙開工具車

- This trolley is equipped with the laptop panel which can place the laptop on and helps do diagnosis service or software tuning.
- Double sided design makes it more convenient to take out the tools.
- Dimensions:  
Overall: 765 mm (W) x 490 mm (D) x 948 mm (H)  
Overall plus the 4" casters:  
765 mm (W) x 490 mm (D) x 1050 mm (H)  
1 drawer: 576 mm (W) x 415 mm (D) x 75 mm (H)  
2 drawers: 576 mm (W) x 415 mm (D) x 154 mm (H)



- 此工具車上配有筆記型電腦座，可放置筆電以便於進行車輛系統診斷或車輛軟體調整。
- 雙開設計，可從任一邊拿取工具，讓使用上更為方便。
- 規格：  
工具車尺寸：765 mm (長) x 490 mm (寬) x 948 mm (高)  
工具車加上4" 腳輪之尺寸：  
765 mm (長) x 490 mm (寬) x 1050 mm (高)  
抽屜一尺寸：576 mm (長) x 415 mm (寬) x 75 mm (高)  
抽屜二尺寸：576 mm (長) x 415 mm (寬) x 154 mm (高)





一般修護工具修護設備

General Repair Equipment



011

HWANG CHERNG BIN  
Specialty Tools Inc.



General Repair Equipment

### H.C.B-A1051-1

PUNCHED BOARD (885 mm x 870 mm)

洞洞板 (3尺×3尺)

- The board is designed for hanging up the tools.
- Specification: 885 mm x 870 mm
- NW: 11 KGS GW: 12.3 KGS
- 特別設計來吊掛工具
- 規格：885 mm x 870 mm
- 淨重：11公斤 毛重：12.3公斤



- Delivery without tools

### H.C.B-A1051-2

PUNCHED BOARD (L1800 mm x W865 mm x H20 mm)

洞洞板 (長1800 mm x 寬865 mm x 高20 mm)

- The board is designed for hanging up the tools.
- Specification: L1800 mm x W865 mm x H20 mm
- N.W.: 26 KGS G.W.: 29 KGS
- 特別設計來吊掛工具
- 規格：長1800 mm x 寬865 mm x 高20 mm
- 淨重：26公斤 毛重：29公斤

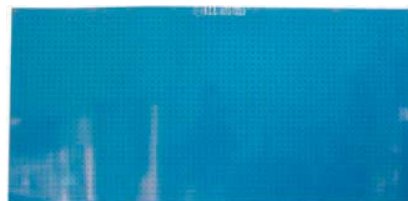

### H.C.B-A1051-3

3" FIXED HOOK

3" 洞洞勾





011

HWANG CHERNG BIN  
Specialty Tools Inc.

一般修護工具修護設備

General Repair Equipment



## H.C.B-A1051-4

PUNCHED BOARD (561 mm x 866 mm x 20 mm)

洞洞板 (561 mm x 866 mm x 20 mm)

- The board is designed for hanging up the tools.
- Specification: L 561 mm x W866 mm x H20 mm
- N.W.: 5.21 KGS
- 特別設計來吊掛工具
- 規格：長561 mm x 寬866 mm x 高20 mm
- 淨重：5.21公斤



General Repair Equipment

**Keep your tools tidy, keep your work tidy.**







一般修護工具修護設備

General Repair Equipment



011

HWANG CHERNG BIN  
Specialty Tools Inc.



## H.C.B-C1051

## TOOL CABINET

### 壁櫃

- Manufactured from heavy steel plate for extra strength and durability.
- Superb quality and 2 lockable door wall cabinet.
- It combines easy access and tool storage with security.
- Dimensions: W: 900 mm D: 215 mm H: 1000 mm
- 厚規格鋼板製造可增加強度與耐久性.
- 具有精湛品質且有上鎖功能的櫥櫃,是保養場技工的最佳儲物櫃!
- 多孔設計可方便拿取與存放.
- 規格: 寬:900 mm 深:215 mm 高:1000 mm



H.C.B-C1051-001

(Not Include tools)

ITEM NO	C1051-002	C1051-003	C1051-004	C1051-005	C1051-006	C1051-007
<b>Description</b>	TOOL HOOK inclined hook end	TOOL HOOK inclined hook end	TOOL HOLDER vertical hook end	TOOL HOLDER double,vertical hook end	TOOL HOLDER double,vertical hook end	TOOL HOOK inclined hook end
<b>PHOTO</b>						
<b>Q'TY</b>	6	5	1	2	3	2
<b>C1051-008</b>	<b>C1051-009</b>	<b>C1051-010</b>	<b>C1051-011</b>	<b>C1051-012</b>	<b>C1051-013</b>	<b>C1051-014</b>
TOOL HOOK for wrench	TOOL HOLDER double,vertical hook end	TOOL HOLDER double,vertical hook end	SPRING CLAMP	Ø4 x 50 L TOOL HOLDER for wrench	Tool holder for screwdrivers	ROUND HOLDER
1	12	1	2	3	1	1
<b>C1051-015</b>	<b>C1051-016</b>	<b>C1051-017</b>	<b>C1051-018</b>	<b>C1051-019</b>	<b>C1051-020</b>	<b>C1051-021</b>
Socket holder	Socket holder	Socket holder	Socket holder	Socket holder	Tool holder for screwdrivers	Tool holder for screwdrivers
1	2	1	1	1	2	3
<b>C1051-022</b>	<b>C1051-023</b>	<b>C1051-024</b>	<b>C1051-025</b>	<b>C1051-026</b>	<b>C1051-027</b>	
Tool holder for toque wrench	Tool holder for screwdrivers	Tool holder	Drill-bit holder With 5 holes	TOOL HOLDER double, vertical hook end	clamp	
2	1	2	1	14	100	





011

HWANG CHERNG BIN  
Specialty Tools Inc.

一般修護工具修護設備

General Repair Equipment



General Repair Equipment

### H.C.B-A2230

### Dr. 3/4" TX-STAR & SPLINE IMPACT BIT SOCKET KIT (6 PCS)

Dr. 3/4" 氣動星形12角凸型套筒組 (6 PCS)

10/18.2/18.7/0.72'

- TX-Star: T70, T80, T90, T100
- ★ Spline: M16, M18
- Length: 61 mm
- Material: CR-MO
- M16 Application:  
Touareg Phaeton from 2003
- M18 Application:  
Touran 2004. Audi A3 from 2004



### H.C.B-B2230

### 3/4" SQ. DRIVE HEXAGON & SPLINE IMPACT BIT SOCKET KIT (9 PCS) (61 mm) (14/17/19/21/22/23/24 mm/M16/M18)

Dr. 3/4" 氣動六角&12角套筒組 (9 PCS) (61 mm) (14/17/19/21/22/23/24 mm/M16/M18)

- Material : CR-MO with special blue finish or manganese phosphate
- Overall Length: 61 mm
- Size:  
Hexagon : 14, 17, 19, 21, 22, 23, 24 mm  
Spline : M16, M18
- Suitable for using with any impact tool.
- 全長: 61 mm
- 尺寸: 六邊形 : 14, 17, 19, 21, 22, 23, 24 mm  
方形 : M16, M18
- 可搭配氣動工具使用



### H.C.B-C2230

### 3/4" SQ. DRIVE HEXAGON & TX-STAR IMPACT BIT SOCKET KIT (9 PCS) (61 mm) (19/21/22/23/24 mm/T70/80/90/100)

Dr. 3/4" 氣動星形12角凸型套筒組 (9 PCS) (61 mm) (19/21/22/23/24 mm/T70/80/90/100)

- Material : CR-MO with special blue finish or manganese phosphate
- Overall Length: 61 mm
- Size:  
Hexagon: 19, 21, 22, 23, 24 mm  
Star: T70, T80, T90, T100
- 全長: 61 mm
- 尺寸: 六邊形 : 19, 21, 22, 23, 24 mm  
星形: T70-T80-T90-T100
- 可搭配氣動工具使用



### H.C.B-A2283

### Dr.1/2" DEEP IMPACT SOCKET KIT (13 PCS) (10/11/12/13/14/16/17/19/21/22/24/27/30 mm)

Dr.1/2" 長型氣動套筒組 (13 PCS) (10/11/12/13/14/16/17/19/21/22/24/27/30 mm)

- Size: 10 mm, 11 mm, 12 mm, 13 mm, 14 mm, 16 mm, 17 mm, 19 mm, 21 mm, 22 mm, 24 mm, 27 mm, 30 mm
- 尺寸: 10 mm, 11 mm, 12 mm, 13 mm, 14 mm, 16 mm, 17 mm, 19 mm, 21 mm, 22 mm, 24 mm, 27 mm, 30 mm





一般修護工具修護設備

General Repair Equipment



011

HWANG CHERNG BIN  
Specialty Tools Inc.



General Repair Equipment

## H.C.B.-B2138

### WORKING TABLE (CABINET)

美式工作桌 (加壁櫃)

- W 1525 x D 700 x H 1520
- 12 mm, block fiberboard
- Tolerate the hammer beating without destroying the surface and the structure.
- Take round angle for preventing from wounded.
- The length is suitable to hang on and take out.



## H.C.B.-B2138-1

### FIXED HOOK

壁櫃掛鉤

ITEM NO.	SIZE (INCH)
B2138-1-A	1"
B2138-1-B	2"
B2138-1-C	4"
B2138-1-D	8"



## H.C.B.-A2316

**NEW**

### MECHANICS CREEPER

臥板

- Made from durable, rust-proof fiberglass.
- Comfortable ergonomic shape.
- Six wheels (hard rubber for smooth operation).
- Convenient tool trays.
- Easy-to-clean surface.
- Dimensions: 104.5x517 mm.

- 耐用、防銹玻璃纖維製成。
- 舒適的人體工學造型。
- 六個輪子 (硬質橡膠讓運作更順利)。
- 工具托盤讓你方便放置物品。
- 易於清潔的表面。
- 尺寸 : 104.5x517 mm





011

HWANG CHERNG BIN  
Specialty Tools Inc.

一般修護工具修護設備

General Repair Equipment



## H.C.B-A6005-5

## TOOL HOLDER (5 SLICES)

工具櫃(五片)



ITEM NO.	Description
A6005-3	<b>3 slices</b>
A6005-4	<b>4 slices</b>
A6005-5	<b>5 slices</b>
A6005-8	<b>8 slices</b>

- Easy to install with the removal, transportation.
- Small size, double hooks, you can hang a variety of tools.
- The plate thickness 1.5 mm, robust, easy to change.
- Customize: Can be made according to customer requirements size with color

- 易於安裝和拆卸, 運輸體積小
- 雙面掛鉤, 可以掛各種工具
- 板子厚度1.5 mm, 堅固結實, 不易變型
- 可根據客戶要求做尺寸和顏色

**H.C.B tool car always sends immediate help to those who have problem repairing their vehicles.**







SINCE 1990

# H.C.B

HWANG CHERNG BIN  
Specialty Tools Inc.

## TRUCK FLYWHEEL TOOLS



**H.C.B-A1618**  
IVECO DUAL GEAR ENGINE  
FLYWHEEL ROTATOR  
(WITH 2 GEARS)



**H.C.B-A1634**  
RENAULT MAGNUM TRUCK  
ENGINE FLYWHEEL  
ROTATOR (Dr. 1/2")



**H.C.B-A1492**  
BENZ & MAN FLYWHEEL  
ROTATING TOOL  
(WITH 2 GEARS)(Dr. 1/2")



**H.C.B-A1493**  
BENZ & MAN FLYWHEEL  
ROTATING TOOL  
(WITH 3 GEARS)(Dr. 1/2")



**H.C.B-A1494**  
MAN FLYWHEEL ROTATING TOOL  
(WITH 1 GEARS)(Dr. 1/2")



**H.C.B-A1175**  
VOLVO (MP7)  
FLYWHEEL TURNING TOOL



**H.C.B-A1244**  
DAF TRUCK FLYWHEEL  
ROTATOR (35 -42 TONS)(EURO 3)



**H.C.B-B1175**  
VOLVO (MP8/MP10)  
FLYWHEEL  
TURNING TOOL



**H.C.B-A1398**  
DAF TRUCK FLYWHEEL  
ROTATOR (35-42 TONS) (EURO 4)



**H.C.B-A1227**  
SCANIA TRUCK CRANK  
ALIGNMENT (Dr. 1/2")

### HWANG CHERNG BIN SPECIALTY TOOLS INC.

Address: No.25-120, Shiyizhi, Longder Village, Shueishang  
Township, Chiayi County, 60859, Taiwan

Tel: 886-5-2600820, 886-5-2603816

Fax: 886-5-2603817, 886-5-2601595

E-mail: service@hcb-autotools.com.tw

hcb@hcb-autotools.com.tw

[www.hcb-autotools.com](http://www.hcb-autotools.com)







# HWANG CHERNG BIN Specialty Tools Inc. National Tools trade show



**FRANKFURT  
AUTOMECHANIKA SHOW**



**ITALY AUTOPROMOTEC  
SHOW**



**FRANCE EQUIP AUTO SHOW**



**TAIWAN AMPA SHOW**



**RUSSIA MIMS SHOW**



**MIDDLE EAST  
AUTOMECHANIKA SHOW**



**USA AAPEX SHOW**



**POZNAN TTM  
AUTOMOTIVE SHOW**



**KOREA KOAA SHOW**



**JAPAN IAAE SHOW**







SINCE 1990

# HWANG CHERNG BIN Specialty Tools Inc.



**PICTURE TAKEN WITH LEBANON  
CLIENT IN 2009 AMPA SHOW**



**PICTURE TAKEN WITH ISRAEL CLIENT  
IN 2013 AUTOPROMOTEC SHOW**



**PICTURE TAKEN WITH CYPRUS  
CLIENT IN 2010 FRANKFURT  
AUTOMECHANIKA SHOW**



**AUSTRALIAN CLIENT VISITED  
H.C.B COMPANY**



**PICTURE TAKEN WITH NEW ZEALAND  
CLIENT IN 2014 AAPEX**



**PICTURE TAKEN WITH GERMANY  
CLIENT IN 2010 FRANKFURT  
AUTOMECHANIKA SHOW**





SINCE 1990

# HWANG CHERNG BIN Specialty Tools Inc.



PICTURE TAKEN WITH AUSTRALIAN CLIENT IN 2015 AMPA SHOW



PICTURE TAKEN WITH INDONESIAN CLIENT IN 2008 AMPA SHOW



PICTURE TAKEN WITH JAPANESE CLIENT IN 2009 AMPA SHOW



PICTURE TAKEN WITH POLAND CLIENT IN 2014 FRANKFURT AUTOMECHANIKA SHOW



PICTURE TAKEN WITH MALAYSIA CLIENT IN 2014 AMPA



PICTURE TAKEN WITH HONG KONG CLIENT IN 2012 AMPA SHOW





**HWANG CHERNG BIN**  
Specialty Tools Inc.

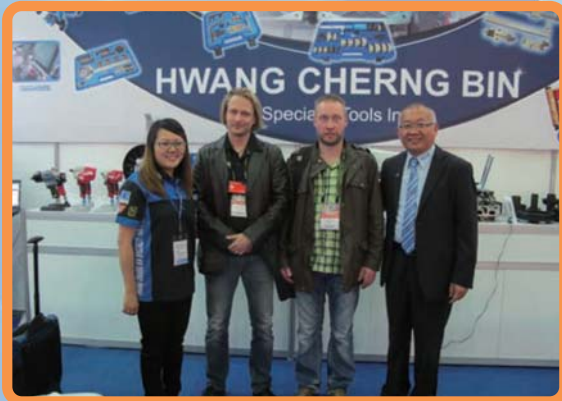

**PICTURE TAKEN WITH FINLAND  
CLIENT IN 2015 AMPA SHOW**



**PICTURE TAKEN WITH IRELAND  
CLIENT IN 2012 AUTOMECHANIKA  
FRANKFURT SHOW**



**PICTURE TAKEN WITH FINLAND  
CLIENT IN 2014 AUTOMECHANIKA  
FRANKFURT SHOW**



**PICTURE TAKEN WITH LITHUANIA  
CLIENT IN 2012 AUTOMECHANIKA  
FRANKFURT SHOW**



**PICTURE TAKEN WITH CHINA CLIENT  
IN 2012 FRANKFURT AUTOMECHANIKA  
SHOW**



**PICTURE TAKEN WITH KOREAN  
CLIENT IN 2013 KOAA SHOW**









H.C.B-A1337



H.C.B-A1339



H.C.B-F1181



H.C.B-A1635



H.C.B-C1391



H.C.B-A2309



H.C.B-A1641



SINCE 1990

No. 25-120, Shiyizhicho, Longder Village,  
Shuishang Township, Chiayi County, 60859, Taiwan  
TEL:886-5-2603816 , 886-5-2600820  
FAX:886-5-2603817 Order FAX:886-5-2601595  
E-mail: hcb@hcb-autotools.com.tw  
service@hcb-autotools.com.tw

[www.hcb-autotools.com](http://www.hcb-autotools.com)

Location:23.43001N,120.38757E

201603

