

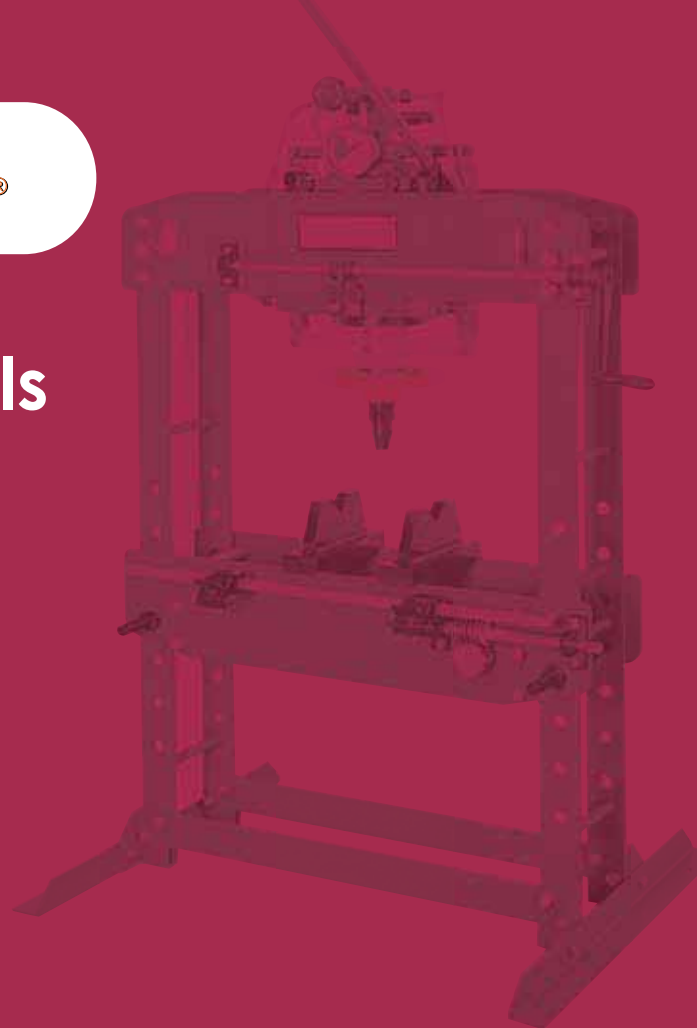

JONNESWAY[®]
PROFESSIONAL TOOLS SERIES

Automotive Repair Tools

- Designed for industrial and construction jobs.
- All metal construction and hand size release knobs make these pumps truly industrial grade tools.
- Rugged construction with simplicity of design provides longer life expectancy.
- Heavy duty design makes them ideal for a wide variety of automotive, truck, industrial and construction work.



CE DIN

ANSI



AB010001
WINDSHIELD INSTALLATION KIT



Specifications :

- A. Rope Insert Tool
Use this tool to insert the rope into rubber gasket.
The handle feeds rope through its stem as you pull it around the gasket.
- B. Assort Tip For Insert Tool :
For inserting locked strip into windshield seal.
Different shaped heads interchange for most types of locking strip.
- C. Curved Hook Tool :
Curved hook tool used for inserting and cleaning rubber gaskets.
- D. Straight hook tool used for inserting and cleaning rubber gaskets.
- E. Cleaning Tool :
Designed for the removal of broken glass for the side runners without removing them.



AB010002
WINDSHIELD REMOVAL KIT



Specifications :

- A. Wire.
Three strong galvanized steel wires are braided to form one wire.
- B. Wire Gripping Handles x2 pcs :
A & B Feed the wire through the hole in the wedge shaft.
Loop it through the hole at the top of the shaft.
Then back into the handle.
Pressing the wedge back into the handle, the wire is hold.
- C. Windshield Removal Tool :
Cuts the butyl adhesive compound around windshield.
- D. Wire Feeder Tool :
Designed for easy and flexible insertion of wire through polyurethane, allowing speedy removal of bonded windshield.
- E. Trim Pad Remover :
Place the tool under the edge of the door upholstery panel and insert it into the fastener as far as possible, then simple pack pry up.
- F. Windshield Molding Release Tool :
Use for removal of Windshield molding.

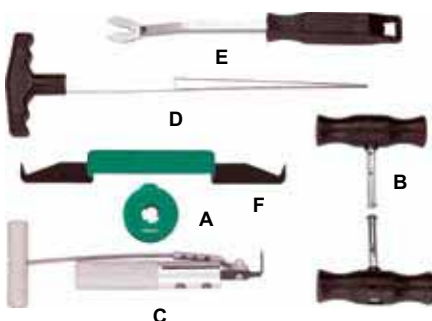

AB010013
WINDSHIELD CUT-OUT WIRE



AB010026S
5 PCS HANDY REMOVER SET



Contents :

- AB010026A : wedge set
- AB010026B : wedge set
- AB010026C : handy remover
- AB010026D : remover wide type
- AB010026E : remover pull type

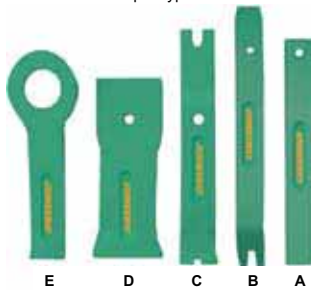

AB020003
SUCTION LIFTER WITH TWO VACUUM CUP



- Lever operated vacuums
- 2 x120mm diameter rubber suction cups
- Lifting action will not damage contact surface
- For use on windscreens glass,tiles,plastic, or other smooth surfaced non-porous materials.



AB030024
IGNITION LOCK & RADIO & HOOK TOOL SET

- Ignition Lock Removal Tool Set
Contains : 2 removal tools for Model W 126 ;
2 removal tools for Models W 124 & 201
- Pair of Hooks
For removing instrument cluster. Applicable :
Models W 107, 116, 123, 124, 126, 140 & 201
- Radio removal tool
To radio removal on 1992 and newer MERCEDES.
Applicable : Models 140, 129, 202 & 210

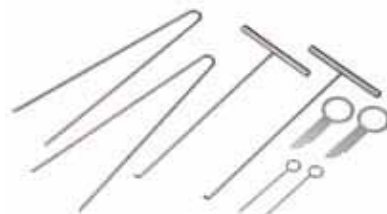

AB030028
CAR DOOR UPHOLSTERY REMOVER

- Removes upholstery clips in seconds.
- This perfectly balanced alloy forged tool is attached with plastic handle, with a bright plated blade.



AB030056
AIR INFLATE FOR UNLOCK DOOR (VEHICLE)



- This inflate design easily and safely to separate the door frame from the vehicle body.

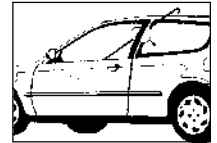

AB030068
BODY PRY BARS

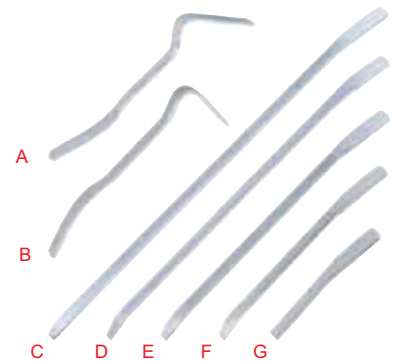

ITEM NO.	LENGTH
AB030068A	380MM
AB030068B	380MM
AB030068C	900MM
AB030068D	750MM
AB030068E	600MM
AB030068F	450MM
AB030068G	240MM

AB030069
BODY WEDGE TOOLS

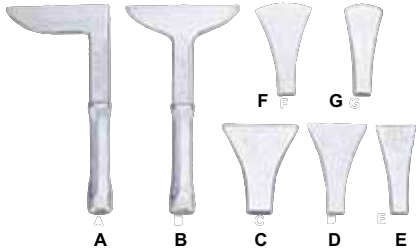

ITEM NO.	WIDTH	LENGTH
AB030069A	125MM	255MM
AB030069B	137MM	255MM
AB030069C	92MM	110MM
AB030069D	70MM	110MM
AB030069E	48MM	110MM
AB030069F	70MM	110MM
AB030069G	48MM	110MM

AE010015A
10 TON HEAVY DUTY COLLISION REPAIR KITS, TWO SPEED PUMP
(DROP FORGED)



ITEM NO.	DESCRIPTION	Q'TY
AE010015A-01	Heavy-duty hydraulic hand pump	1
AE010015A-02	Jack hose, 6 feet	1
AE010015A-03	10 Ton ram with 6" stroke	1
AE010015A-04	1/2 Ton hydraulic spreader ram	1
AE010015A-05	19" Extension tube	1
AE010015A-06	14" Extension tube	1
AE010015A-07	10" Extension tube	1
AE010015A-08	5" Extension tube	1
AE010015A-09	Male connector	1
AE010015A-10	Flat base	1
AE010015A-11	90° "V" base	1
AE010015A-12	Wedge head	1
AE010015A-13	Plunger toe	1
AE010015A-14	Ram toe	1
AE010015A-15	Rubber flex head	1
AE010015A-16	Serrated saddle	1
AE010015A-17	Blow-molded case	1

Features :

- A professional 4 ton body and frame repair tools are your best choice for collision repair, industrial and construction applications where convenience of hydraulic power can be utilized for spreading, clamping, pulling and lifting operations.
- Made of rugged and welded construction, the hand pump base is forged using SS400 material to prevent oil leakage from extreme usage.
- Accessory components are forged for the best in strength and rigidity, ensuring safety standards are met and parts do not break.
- Snap connectors for quick operation.

AE010015
10 TON COLLISION REPAIR KIT
(TWO SPEED PUMP)



ITEM NO.	DESCRIPTION	Q'TY
AE010015-01	Hydraulic Hand Pump	1
AE010010-02	Jack Hose, 5 feet	1
AE010010-03	10 Ton Ram With 6" Stroke	1
AE010010-04	1/2 Ton Hydraulic Spreader Ram	1
AE010010-05	19" Extension Tube	1
AE010010-06	14" Extension Tube	1
AE010010-07	10" Extension Tube	1
AE010010-08	5" Extension Tube	1
AE010010-09	Male Connector	1
AE010010-10	Flat Base	1
AE010010-11	90° "V" Base	1
AE010010-12	Wedge Head	1
AE010010-13	Plunger Toe	1
AE010010-14	Ram Toe	1
AE010010-15	Rubber Flex Head	1
AE010010-16	Serrated Saddle	1
AE010010-17	Blow Molded Case w/Wheels	1

AE010025A
4 TON HEAVY DUTY COLLISION REPAIR KITS, TWO SPEED PUMP (DROP FORGED)



ITEM NO.	DESCRIPTION	Q'TY
AE010025A-01	Heavy-duty hydraulic Hand Pump	1
AE010025A-02	Jack hose, 6 feet	1
AE010025A-03	4 ton ram with 4" Stroke	1
AE010025A-04	1/2 ton hydraulic spreader ram	1
AE010025A-05	16" Extension tube	1
AE010025A-06	12" Extension tube	1
AE010025A-07	8" Extension tube	1
AE010025A-08	4" Extension tube	1
AE010025A-09	Male connector	1
AE010025A-10	Flat base	1
AE010025A-11	90° "V" base	1
AE010025A-12	Wedge head	1
AE010025A-13	Plunger toe	1
AE010025A-14	Ram toe	1
AE010025A-15	Rubber flex head	1
AE010025A-16	Serrated saddle	1
AE010025A-17	Blow molded case with wheels	1

Features :

- A professional 10 ton body and frame repair tools are your best choice for collision repair, industrial and construction applications where convenience of hydraulic power can be utilized for spreading, clamping, pulling and lifting operations.
- Made of rugged and welded construction, the hand pump base is forged using SS400 material to prevent oil leakage from extreme usage.
- Accessory components are forged for the best in strength and rigidity, ensuring safety standards are met and parts do not break.
- Snap connectors for quick operation.

AE070002
TRANSMISSION JACKS



ITEM NO.	CAPACITY (kg)	A (mm)	B (mm)	C (mm)	D (mm)	E (mm)	F (mm)	N.W. (kg)	G.W. (kg)	CUFT
AE070002	600	720	1120	1840	320	1000	690	37.2	40.2	3.0

AE080004
TELESCOPIC TRANSMISSION JACKS
Capacity : 800 KGS

- For use with transmissions and transaxles of passenger cars and light trucks.
- Foot-operated pump for maximum lift with minimum effort and fast contact with load.
- Fully adjustable universal saddle with adjustable corner brackets and safety chain for optimum alignment of transmission bolt patterns.
- Safety overload system protects jack from being used beyond its rated capacity.
- N.W. 68KGS G.W. 71KGS CUFT 3.4'



AE080014
DOOR LIFT
CAPACITY : 250 kg

- Ideally designed for removing and installing various kind doors of vans, passenger cars and trucks.
- Allow easy one-man operation. Help you to save manpower, time and raise efficiency as well as quality work.
- Foot-operated hydraulic jack and lowering pedal allow for easy control of the raise and descent of the load.
- Adjustable mounting bars can hold doors of most sizes : preventing the door from being damaged with rubber pads.
- Four swivel caster wheels and a push handle provide easy maneuvering and the brakes on the two rear swivel caster wheels provide easy positioning.



AE090024
ALUMINUM RACING CAR SERVICE JACK



ITEM NO.	AE090024 (MM)	AE090024 (INCH)
MAX. LOAD CAPACITY	1500 kg	3300 lbs
MIN. SADDLE HEIGHT	87 mm	3-1/2"
MAX. SADDLE HEIGHT	445 mm	17-5/8"
JACK SIZE (LxWxH)	600x310x157	23-3/4"x12-1/4" x6-1/2"
HANDLE LENGTH	1270 mm	50"

PUMP TIMES	0	1	2	3	4	5	6	6-1/2
STROKES	87	155	217	276	331	381	427	445

AE110020
20 TON AIR HYDRAULIC JACK



ITEM NO.	CAPACITY (TON)	A (mm)	B (mm)	C (mm)	D (mm)	E (mm)	F (mm)	G (mm)	HOSE LENGTH (mm)	HANDLE LENGTH (mm)	AUXILIARY HEIGHT (mm)
AE120020	20TON	205	291	377	86	86	490	1155	5'	630	95

Features :

- Low profile design for most of industrial applications.
- Forging base as the strongest construction to catch the needs in industry market.
- Housing welding onto the forged base makes to be free from leakage problem as well.
- Telescopic design of AE110020 reaches the extra height needed during operating to save time and labor cost.
- AE110020 equipped with two large Dia. Rubber wheels provide the greatest convenience and mobility you need.
- Air / Hydraulic design make you free pumping handle also with the most efficiency and time saving.

AE120018
35 TON INDUSTRIAL HYDRAULIC SHOP PRESS

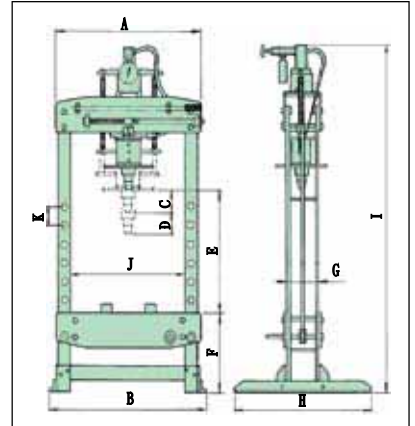

ITEM NO.	A (mm)	B (mm)	C (mm)	D (mm)	E (mm)	F (mm)	G (mm)	H (mm)	I (mm)	J (mm)	K (mm)
AE120018	1000	1080	110	80	530	410	236	850	1730	790	95

Application :

1. Each kind of mechanical part bends and deforms, combined for reformation.
2. Each kind of mechanical part, shaft bearing, etc. is pressed in or extruded in application.

It is a necessary tool for vehicle or mechanical maintenance industry.

Features :

The oil tube is made of high pressure steel tube by Germany and NOK piston ring, through compliance with precision oil path treatment process, making this machine to attain its top property.
Capacity : 35 ton Cylinder bore : 80mm Pressure : 300 Kg/cm²
Length : 1080mm Width : 850mm Height : 1730mm
N.W. : 320kg G.W. : 380kgs CU.FT. : 36'

AE130002

ENGINE CRANES
CAPACITY : 1,000 kg

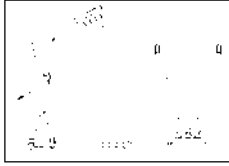

Features :

- Four position telescopic boom with forged steel grab hook.
- Quick foldable legs save shop space and prepare crane for transportation or storage within seconds.
- Four full swivel casters provide easy manoeuvring and positioning.
- 4" dia. front wheels and two rear swivel casters with brake provide positive steering and easy manoeuvring.
- Hand release knob valve for easy and precise control.
- New 5 Ton capacity long stroke ram is designed with swivel handle to provide fast engine removal and replacement from any direction.
- N.W. 91 kg G.W. 106 kg CUFT. 14'

AE140013

ENGINE STANDS
CAPACITY : 600 kg

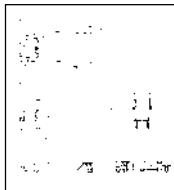

Features :

- Ideal engine stand for car and light truck engine service.
- Four adjustable arms attached make engine mounting fast and easy.
- Gear box allows full rotating service for the mounted unit being removed as the best location, just with turning of the crane. It provides manpower-saving extremely.
- Four swivel all bearing caster wheels provide stability and easy maneuvering.
- To conserve valuable for space, the legs being able to fold into a compact package for storage.

AE140017

**GEAR TYPE UNIVERSAL
K / D RACK**



- The gear type universal K/D rack is designed for engine maintenance only.
- The gear type universal K/D rack can be removed and be replaced with AE140017-3 C-type holder base for transmission maintenance if necessary.
- The gear and engine can be pivoted from 360 degrees during operation. Whenever the gear turning around, the engine will be rotated passively at the same time.
- The K/D rack is time, money, and strength saver.
- The K/D rack can be folded for storage.

AE140017-2

DRAIN PAN



AE150005

**3 TON JACK STANDS W/RUBBER
PADS**



ITEM NO.	CAPACITY (ton)	ADJUSTING HEIGHT (mm)	BASE AREA	Q'TY /CARTON	N.W. (kg)	G.W. (kg)	CUFT
AE150005	3	310-445	190x216mm	1 Pair	7.8	8.5	0.7

AE170001

ENGINE POSITIONER

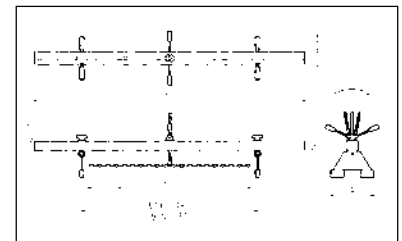

AE170002

TRANSVERSE ENGINE SUPPORT

- Straddling the inner fender walls and acting as a bridge to support engines.
- Adjustable in height and width to bridge various vehicle fender walls and securely hold engine in place.
- Including slider bolt that can be positioned anywhere on the bar for the best weight distribution.
- The supporting plates with flex design can match all kinds angles of the inner fender walls.
- The supporting plates equipped with rubber pads to prevent the auto body from damage.

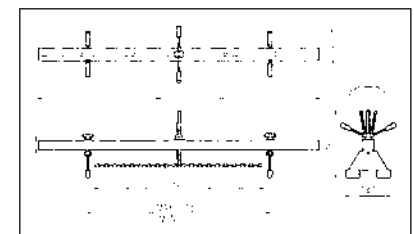
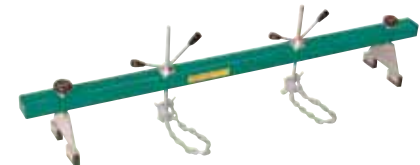

AE170006
UNIVERSAL TRANSVERSE ENGINE SUPPORTS

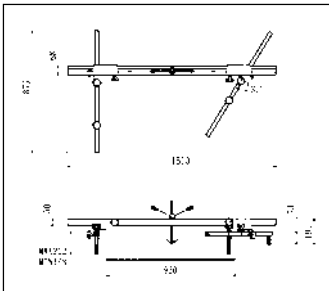

Features :

- Special new design for 4 fixing point to be a bridge to support the engine.
- Especially using one the car that without inner fender.
- Adjustable in height and width to bridge various vehicle fender walls and securely hold engine in place.
- With rubber in the 4 fixing point to prevent slip or damage the vehicle.
- AE170006 equipped with two feet to use on the car with inner fender.
- N.W. 38 kg G.W. 40 kg CUFT. 2.5

AE300061
OIL EXTRACTOR

- Capacity : 6.5 Liters
- For DIY or professional use.
- Simple and easy to operate.
- Suitable for engine oil, gear oil, transmission and brake fluid water.



AE300064
17 PCS RADIATOR PRESSURE TESTER



- Pressure testing kit comprising of adaptors, hand pump and airline regulator assembly.
- Bespoke adaptor are for Audi, BMW, Citroen, Fiat, Ford, (Vauxhall / Opel), Peugeot, Volvo and Volkswagen.
- Universal stationary seat multi-fit adaptors suitable for most vehicles.
- Quickly detects leaks in car radiator or hose system.
- Storage case features identification numbers for all accessories.
- Comprehensive instruction booklet enclosed.

AE300072
AIR OPERATED GREASE PUMP



- Can have capacity 12-22kg original bucket grease or in bulk 30L grease suit for 00# - 2# grease.
- Can have capacity 12-22kg original bucket grease or grease suit for 00# - 2# grease.

Capacity	Air inlet pressure	Pressure Ratio	Fluid output press	Deliver Rate	Hose Length
30L	4-9 KG/CM ²	45 : 1	180-405 kg/cm ²	30c.c./sec	10 ft

AE300095
14PCS RADIATOR PRESSURE TESTER



- Detecting leak of car radiator or tube system precisely, rapidly.
- Offer professional service quality, and easy operation.
- Conform every kind of car radiator's opening diameter & high quality of full-set accessories.
- The main body is Aluminum Alloy material.

AE300099
UNIVERSAL PIPELINE CLEANING AND LEAK CONNECTOR



Thread Adaptor



Flat Adaptor

Contains :

- A : convex cone connector dia. 5-15
- B : convex cone connector dia. 11-20
- C : convex cone connector dia. 16-25
- A1 : cone-shaped rubber washer dia. 6-18
- B1 : cone-shaped rubber washer dia. 13-24
- C1 : cone-shaped rubber washer dia. 18-30
- D,E : special hole connector
- F : concave cone connector dia. 7-13
- G : flat connector dia. 10-18
- H : flat connector dia. 16-24
- I : cleaner connector 7/16*20unf
- J : 90° angle connector
- K,L : special clamp
- M : C-shaped clip, 28mm
- N : C-shaped clip, 40mm
- P : tool-free nut
- Q : fastening bolt, 7/16*20unf
- R : plug connector, 7/16*20unf
- blowing case

AE300102
WASTE OIL STORAGE

Capacity : 24 L / Size : 820x540x200 mm/
Weight : 1.8 kgs



AE300103

16L WASTE OIL STORAGE

Capacity : 16 L / Size : 600x450x180 mm/
• Weight : 1.05 kgs



AE300105

30L WASTE OIL DRAINER



ITEM NO.	AE300105
DIMENSION	500 x 550 x 880~1050 m/m
CAPACITY	30 L
WEIGHT	8.9 kgs
POWER	Manual

- Composite lid and drum with 30L reservoir and drain pan on telescopic post.
- Gravity drain using tap on rear of unit.
- Includes visible 'Full Drum' device.
- Includes large diameter drain pan insert and heavy duty mesh for draining oil filters.
- Made from high density Polyethylene.

AE300106

MANUAL OPERATED GREASE DISPENSER



ITEM NO.	AE300106
Cylinder Material	Aluminium
Capacity	30L
Applied Pressure	Manual Operated
Pressure Ratio	1:1
Flow Capacity	75 cc/cycle
Hose Diameter	1/4" x 10ft
Weight	10.90 kgs

AE300109

MANUAL OPERATED OIL DISPENSER



ITEM NO.	AE300109
Cylinder Material	ALUMINIUM
Capacity	30 L
Applied Pressure	Manual Operated
Pressure Ratio	1 : 1
Flow Capacity	75cc/cycle
Hose Diameter	1/2" x 10ft
Weight	11.30 kgs

AE300118

AIR POWER PARTS WASHER W/TURBO BLOWER GUN

Bucket capacity : 20 Gallons
Solvent capacity : 12 Gallons
Flow rate : 75 Gallons
Maximum speed : 11000 rpm
Range of working pressure : 65-125 psi
Air inlet : 1/4"
Size : 31-7/8" L x 20-7/8" W x 35-3/8" H



ITEM NO.	AE300118
Power Source	AIR COMPRESSOR
Overall Dimension	31-7/8" x 20-7/8" x 35-3/8"
Tank dimension	265x500x730mm (10-5/8"x20-3/4"x29-7/8")
Max. working capacity	12 GALLONS
Min. working capacity	6 GALLONS
Max. tank capacity	20 GALLONS
Pump output thru spigot	250 L/H
Closed height	890mm (35-1/2")
Open height	1344mm (52-9/10")
Net weight	31 kgs
Gross weight	34 kgs

- Self-latching fusible linked cover for safety.
- Magnetic sealless fully enclosed electric pump and / or patent pending pneumatic pump.
- One-piece-formed tank or rugged steel welded tank by EPOXY paint baked finish compatible with most solvent.
- Convenient on / off switch with indicator light.
- Removable work shelf and parts basket.
- Optional turbo-action air agitator creates a continuous scrubbing effect for faster cleaning than conventional dip tanks.

AE300146

BRAKE BLEEDER FOR PROFESSIONALS



- The universal brake fluid bleeder applied on cars and motorcycles
- Automatic refilling design to speed up and simplify the operation
- An extra magnet is equipped for fixing refilling bottle in position
- The universal rubber adapter fits on any bleed screw
- Comes with a vacuum bleeder bleeding hose and a refilling bottle

SPECIFICATIONS :

- Material of Blow Gun : P.O.M.
- Canister Capacity : 0.75 Litre
- Working Temperature : -3 F~120 F
- P.V.C. Hose : 2 M
- Blow Gun Air Inlet : 1/4"
- Noise level : 70~75 dB
- Air consumption : 6.5 CFM
- Working pressure : 75-120 PSI
- Vacuum : -13.5' Hg(-35Cm / Hg)

AE310001

6 WAYS MULTI PURPOSE HYDRAULIC GEAR PULLER



CONTENTS:

- 1pc Hydraulic Ram (SCM415 ϕ 37.7MM x L 160 x 16t)
- 1pc Combination Cross Head (Carbon Steel)
- 3pcs Combination Leg (SCM415 Drop Forged Hardened 42° ~ 45°)
- 6pcs Steel Plate
- 1pc Extension Rod (1" x 1-1/4" Carbon Steel)
- 1pc Extension Rod (1" x 2" Carbon Steel)
- 6pcs Screw Nut & Washer



AE310002
25PCS HYDRAULIC GEAR PULLER



CONTENTS:

- 1pc Hydraulic Ram (SCM415 ϕ 37.7mm x L160 x 16t)
 - 3pcs 4" Leg Hardened 42° ~ 45° (SCM415)
 - 3pcs 6" Leg Hardened 42° ~ 45° (SCM415)
 - 3pcs 8" Leg Hardened 42° ~ 45° (SCM415)
 - 1pc Twin Head
 - 1pc Triple Head
 - 1pc Sent Pop (Carbon Steel)
 - 1pc Extension Rod (1" x 2" Carbon Steel)
 - 1pc Extension Rod (1" x 4" Carbon Steel)
 - 2pcs Main Rod (8" x 1.75p Carbon Steel)
 - 2pcs Extension Rod (8" x 1.75p Carbon Steel)
 - 1pc Beam (Carbon Steel)
 - 1set Bearing Separator & Bolts (SCM415 Drop Forged Hardened 42° ~ 45°) Capacity 75mm-105mm
 - Bolt 5/8" x 18t Capacity 105mm Carbon Steel (SCM21 415 Hardened 42° ~ 45°)
 - 1pc Nut (Ram Part SCM21 415 Hardened 42° ~ 45°)
- FOR AGRICULTURE MACHINE GARAGE AND INDUSTRY USE

AE310004
HYDRAULIC SEPARATOR PULLER SET

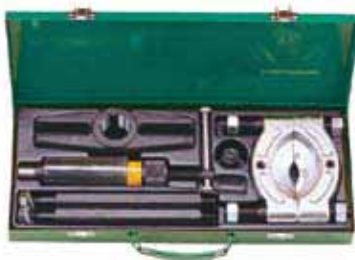

CONTENTS:

- 1pc Hydraulic Ram (SCM415 ϕ 37.7mm x L160 x 16t)
- 1set bearing separator & bolts (SCM415 Drop forged hardened 42° ~ 45° ,capacity 6") (Bolt 5/8"x11ncxL2.16mm ϕ 16mm SCM415)
- 2pcs main rod (hex bar21mmxL7"x5/8"11nc carbon steel)
- 2pcs extension rod (hex bar 21mmxL7"x5/8" 11nc) carbon steel
- 1pc beam, carbon steel
- 1pc adaptor, carbon steel

AE310005
PRESSURE SCREW SEPARATOR PULLER SET

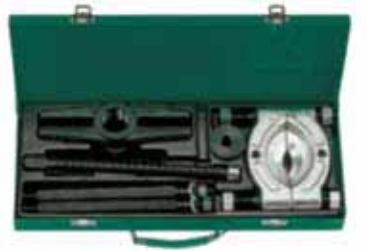

CONTENTS:

- 1pc beam, carbon steel
- 1pc central bolt ϕ 18.65mmxL11.5"x10t
- 1pc nut, carbon steel
- 1set bearing separator & bolts (SCM415 drop forged hardened 42° ~45°, capacity 75-105mm)
- 2pcs main rod (8"x1.75p carbon steel)
- 2pcs extension rod (8"x1.75p, carbon steel)

AE310006
TWO SETS BEARING SEPARATOR ASSEMBLY



CONTENTS:

- 1 set bearing separator & bolts
- 4 pcs main rod (hex bar 17mm x 7/8" x L127mm x 16t)
- 1 pc beam, carbon steel
- 1pc center bolt (9/16" x L 175 x 10t/inch carbon steel)

AE310007
HYDRAULIC SEPARATOR PULLER SET



- 1pc - Hydraulic Ram (SCM415 ϕ 37.7mm x L160 x 16t)
- 1set-Bearing separator & bolts
- 2pcs-Main rod (8"x1.75p carbon steel)
- 2pcs-Extension rod (8"x1.75p carbon steel)
- 1pc-Beam, carbon steel

AE310008
INTERNAL & EXTERNAL PULLER SET



- AE310008-1 T-Bar (S45C Carbon Steel) 5/8 x 18T x L425mm
- AE310008-2 Hammer (S45C Carbon Steel) 53mmxL100mm 1.2kgs
- AE310008-3 Nut
- AE310008-4 Centre Screw
- AE310008-5 Washer
- AE310008-6 Internal Puller Capacity : 15mm-30mm
- AE310008-7 Internal Puller Capacity : 30mm-80mm
- AE310008-8 External Puller Capacity : 15mm-80mm
- AE310008-9 Adapter 31x10
- AE310008-10 Adapter 18x6.5
- AE310008-11 Triple Head
- AE310008-12 Screw

- Size : Small of internal puller 15mm~30mm
Large of internal puller 30mm~80mm
External puller 15mm~80mm
- Locking the nut to open 3-jaws and clip the bearing.
And then use the slide hammer to pull out the bearing.

AE310010
SLIDE HAMMER



- 1pc T Bar (Carbon Steel)
- 1pc Hammer (5Lbs. Cast Iron)
- 1pc Axle Puller (Drop Forged Carbon Steel)
- 1pc Grip Wrench Adapter
- 1pc Nut
- 1pc Two Jaw Head
- 1pc Three Jaw Head
- 3pcs Screw & Nut
- 1pc Attachment
- 3pcs Jaw (Drop Forged Carbon Steel)
- 1pc Tapping Screw
- 1pc Hook

- Increased the coverage with the two axle pullers.
- Works together with other tools is more easy.
- Included 3-Jaw puller and many types of joints.

AE310012
BLIND HOLE BEARING PULLER



- One slide hammer assemble & 4 clamp.
- Attachments for 3/8" to 1/2" (10-14mm), 9/16" to 11/16" (15-19mm), 5/8" to 1" (18-25mm) & 1" to 1-1/4" (25-32mm) I.D. bearings' pulling.
- Open clamps by turning handle clockwise to snug against the bearing for pulling out evenly without damage the parts.

AE310013
UNIVERSAL WHEEL HUB PULLER

SIZE:
90~140mm/3-1/2"~5-1/2"
130~180mm/5-1/8"~7-1/16"



AE310017
3PCS AXLE PULLER

- Axle(Drop Forged)-hardened 42°~45° central hole to screw hole 130mm carbon steel
- T-Bar (5/8"x24"x18t/inch carbon steel)
- Hammer (5Lbs cast iron)



AE310018
WASHER SLIDE HAMMER SET

- Pull with slide hammer with washer in the body.



AE310019
SPOT WELDING SLIDE HAMMER SET

- Directly weld to denting auto body.
- Pull with slide hammer without drilling a hole in the body.



AE310022
PITMAN ARM PULLER



Pitman Arm Puller (SCM 415) Hardened 42°- 43°
Centre Bolt : (S45C Carbon Steel) Hardened 42°- 43°

AE310023
BALL JOINT PULLER

- SCM-4140 Hardened 45°
- Bolt : SCM-4140 Hardened 45°
- Centre Connector : SCM-4140 Hardened 45°

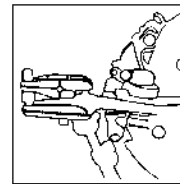
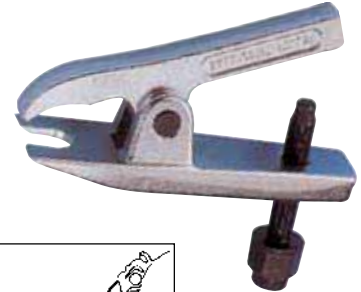

AE310076
UNIVERSAL BALL JOINT PULLER

AE310077
UNIVERSAL BALL JOINT PULLER

- Special steel for removing the ball pivots on steering arms, steering tie rocks, steering knuckles, etc.
- AE310076 - JAWS OPEN : 17mm
- AE310077 - JAWS OPEN : 20mm



AE310076



AE310077

AE310024
BEARING SEPARATOR

- SCM415 Hardened 42° ~ 45°
- Capacity: 1-1/4" - 2-1/4" (30mm x 50mm)
- Bolt ø9.5mm x L 125mm x 3/8" x 24t



50mm

AE310025

BEARING SEPARATOR

- SCM415 Hardened 42° ~ 45°
- Capacity: 2-1/4" - 3-1/2" (50mm x 75mm)
- Bolt ø12.7mm x L 135mm x 1/2" x 20t



75mm

AE310026

BEARING SEPARATOR

- SCM415 Hardened 42° ~ 45°
- Capacity: 3" - 4 - 1/2" (75mm x 105mm)
- Bolt ø16mm x L 165mm x 5/8" x 8t



100 mm

AE310027

BEARING SEPARATOR

- SCM415 Hardened 42° ~ 45°
- Capacity: 4"-6" (105mm x 150mm)
- Bolt ø19mm x L 260mm x 3/4" x 16t



150mm

AE310029-33

2-JAWS CR-V GEAR PULLER



ITEM NO.	SIZE	RANGE (mm)
AE310029	3"	40 - 76
AE310030	4"	50 - 102
AE310031	6"	60 - 152
AE310032	8"	80 - 203
AE310033	12"	120 - 306

AE310034-38

3-JAWS GEAR PULLER



ITEM NO.	SIZE	RANGE (mm)
AE310034	3"	40 - 76
AE310035	4"	50 - 102
AE310036	6"	60 - 152
AE310037	8"	80 - 203
AE310038	12"	120 - 306

AE310048-49

ARMATURE BEARING PULLER



ITEM NO.	DISASSEMBLY OUTWHEEL CAPACITY
AE310048	19-35 mm
AE310049	24-55 mm

AE310062

LONG JAW BEARING PULLER

- Alloy steel hardened 48° ~ 50°
- Jaw Length : 300mm
- Capacity : 10 ~ 50mm



AE310072

DISC BRAKE PISTON SPREADER



AE310073

UNIVERSAL BALL JOINT EXTRACTOR (20MM)

- For splitting track-rod ends, anti-roll bar mountings, ball joints, etc.
- Dimension C is infinitely adjustable so providing a wider application range.



AE310082

BEARING HOLE PULLER KIT

Open clamps by turning handle clockwise to snug against the bearing for pulling out evenly without damage the parts.

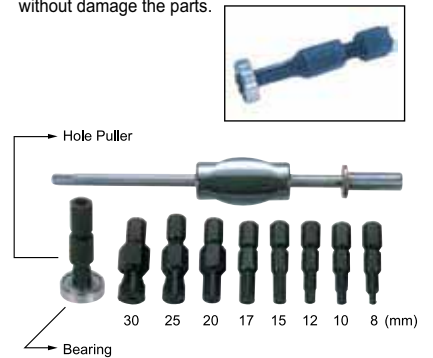

AE310086

LOCKING JAW PULLER SET

- CONTENTS:
- 3PCS-Adjustable reversible jaw 123mm (4-7/8")
 - 3PCS-Adjustable reversible jaw 47mm (1-7/8")
 - 3PCS-Adjustable reversible jaw 32mm (1-1/4")
 - 1PC - Forcing screw
 - 1PC - 2 Way yoke
 - 1PC - 3 Way yoke
 - 1PC - Reversible adjusting nut
 - 3PCS - Screw & nut

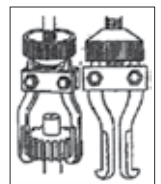

AE310095

4 TON HYDRAULIC PULLER

Features:

- Special package model includes 2/3 jaws puller and 2 jaws puller with attachment in one set.
- Ideal impact package with light PE case for carrying.
- One complete set with two kinds of puller for user's convenience always.

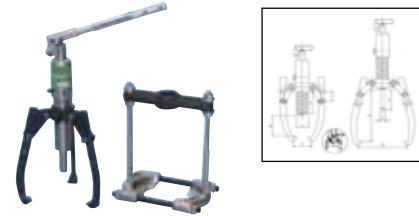

ITEM NO.		AE310095
CAPACITY		4 Ton
REACH (mm)	A	185/250
	B	70
	C	75/55
SPREAD (mm)	D	255/110
	H	60
STROKE (mm)	E	42
	F	22
	G	84
PUMP TIP (mm)	A	11
	B	6
	C	22
	I	32
WEIGHT (kg)		4.5/8.5

AE310110

BALL JOINT EXTRACTOR

SIZE : 23 MM



AE310119

HUB SLIDE HAMMER PULLER (5 HOLES)

- This tool can be used as a regular wheel or hub puller as well as a flange type puller.
- The bolt circle range is from 4-1/2" to 5-1/2"(114-140mm) which covers all major cars and small trucks with flange type axles.
- The four slots in the adapter allow this tool to be used on either 4,5, or 6 bolt or stud designs.
- Has extra heavy 101b. Sliding hammer.



AE310149

4 WAY BALL JOINT REMOVER TOOL

- Heat Treated drop forged steel body & bolt for long rough usage.
- Spread ball joints easily where space prevents use of direct action method.
- Total Length: 165 mm
- Opening Angle: 24 ~ 45 mm
- Jaw Opening: 20mm
- Body Material: SCM440



AE320023~24

HEAVY DUTY COIL SPRING COMPRESSOR

- Drop forged by fully CR-MO and heat treated ensure obtain professional job.
- Can use with air impact wrench.
- The tool is designed for use in limited space under wheel arch.
- Jaw design is fitting to wrap coil claws for safety.



ITEM NO.	MAXIMUM JAW OPENING
AE320023	270mm
AE320024	370mm

AE320003

COIL SPRING COMPRESSOR SET L-300mm



AE320030

SPRING COMPRESSOR FOR MERCEDES BENZ

- Types : 116/123/124/126/129/201/202/140 and 4-Matic includes.
- Advantage : Newly developed automatic 3-point safety interlock and automatic freewheel at end of stroke.



AE320031

BENZ BALL JOINT INSTALLER W123 / 126 / 220

- For pressing ball joint into steering knuckle.
- Application : W123/W126/W220



AE320034

MCPHERSON SPRING DUMPER EXTRACTOR (CHANGEABLE)

- Spring compressors are multi-application tools specifically developed for modern McPherson suspensions, using a range of 3 sets of interchangeable mono block forks.
- Application : BMW, TOYOTA, FORD, MITSUBISHI, VW, AUDI, SAAB, NISSAN, HONDA, ACCORD, SUBARU, VOLVO, OPEL, PORSCHE.



AE320035

SPECIAL VISE FOR SHOCK ABSORBER

- Attaching the pipe vise to the workbench allows repairs to be carried out quickly and cleanly.
- Struts should never be held in a normal workshop vise due to the risk of deforming the strut-tube.



AE320036

HYDRAULIC MCPHERSON SPRING DUMPER COMPRESSOR



- This adjustable mechanical design makes this tool applicable to all lengths of the shock absorbers.
- The metal press plate can be used on the springs which are in high density (smaller clearance).
- With design of adjustable clamp, which can clamp any size of shaking-avoid spring stably to avoid danger when operation.
- Multiple function design apply to all kinds of shaking-avoid spring
- Hooks can be turned 360° and easily take apart shaking-avoid spring.
- Hydraulic design makes the operation quick, safe, and steady.
- 1225mm H x 570mm L x 405mm W



AE330001

CLAMPS

SINGLE DIRECTION OPERATION
CAPACITY : 5 TON



- Bolt size : 16m/m φ x 70L m/m

AE330002

CLAMPS

TWO DIRECTION OPERATION
CAPACITY : 2 TON (CROSS)
5 TON (LONGITUDINAL)



- Bolt size : 16m/m φ x 70L m/m

AE330003

CLAMPS

SINGLE DIRECTION OPERATION
CAPACITY : 3 TON



- Bolt size : 14m/m φ x 120L m/m

AE330004

CLAMPS

SINGLE DIRECTION OPERATION
CAPACITY : 3 TON



- Both side's jaws are different in order to fit the confined room.
- Bolt size : 14m/m φ x 110L m/m

AE330005

CLAMPS

TWO DIRECTION OPERATION
CAPACITY : 2 TON (CROSS)
3 TON (LONGITUDINAL)



- Both side's jaws are different in order to fit the confined room.
- Bolt size : 14m/m φ x 110L m/m

AE330006

CLAMPS

SINGLE DIRECTION OPERATION
CAPACITY : 5 TON



- Special design for operator when they need to powerful pull.
- Bolt size : 20m/m φ x 130L m/m

AE330007

CLAMPS

SINGLE DIRECTION OPERATION
CAPACITY : 2 TON



- The flat design is specilize for the confined room.
- Bolt size : 14m/m φ x 730L m/m

AE330008

CLAMPS

SINGLE DIRECTION OPERATION
CAPACITY : 3 TON (STRAIGHT WAY)
2 TON (CROSS WAY)



- Special mini design is good to use in a narrow and small space.
- Bolt size : 14m/m φ x 45L m/m

AE330009

CLAMPS

SINGLE DIRECTION OPERATION
CAPACITY : 3 TON



- Clipper design to make operators do not need fixed by screws.
- The tool's feature is when operator pull longer and it will tight more.

AE330010

CLAMPS

MULTI-DIRECTION OPERATION
CAPACITY : 5 TON

- The jaw surface can be extended about 3" (75mm)
- Special suitable for internal pulling use



AE330011

CLAMPS

MULTI-DIRECTION OPERATION
CAPACITY : 4 TON

- The jaw surface can be extended about 6" (150mm)
- Special suitable for internal pulling use



AE330012

CLAMPS

MULTI-DIRECTION OPERATION
CAPACITY : 5 TON



- The jaw surface length is 120mm and that is very suitable for thin sheet employed.
- Bolt size : 14m/m φ x 73L m/m

AE330013

CLAMPS

TWO DIRECTION OPERATION
CAPACITY : 3 TON (CROSS)
5 TON (LONGITUDINAL)



- The jaw surface length is 120mm and that is very suitable for thin sheet employed.
- Bolt size : 14m/m φ x 73 L m/m

AE330014

CLAMPS

ALL DIRECTION OPERATION
CAPACITY : 3 TON (CROSS)
5 TON (LONGITUDINAL)
3 TON (MULTI-DIRECTION)



- The jaw surface length is 120mm and that is very suitable for thin sheet employed.
- Bolt size : 14m/m φ x 73 L m/m

AE330015

CLAMPS

TWO DIRECTION OPERATION
CAPACITY : 5 TON



- Bolt size : 14m/m φ x 73 L m/m
- Use the two hooks to pull and fix the car.
- This tool could be clipped to unibody or any other place of the body.
- The puller and hooks are adjustable, it could be charge the range for fitting the place.

AE330024

CHAIN FIXING BASE

- Applicable chain : 5/16", 3/8"
- Include two bolts to fix the stander.

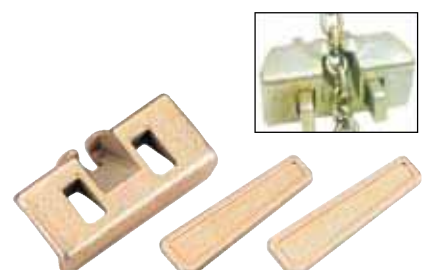

AE330025

DOWN PULLEY ASSEMBLY

- Applicable chain : 5/16", 3/8"
- Include two pins to fix the stander.
- Changing ways with using pulley base.



AE330029

HANDY HOOK

- Pulling after fixing the hook into the indentation.



AE330016

CLAMPS

CAPACITY : 6 TON

- For use as chain shorter or chain connector.
- Use with 5/16" , 3/8" chains.



AE330026

BALL PIVOT BASE

- Applicable chain : 5/16" , 3/8"
- Include two pins to fix the stander.
- Install the model into the indentation to change the way when operator use the tool.

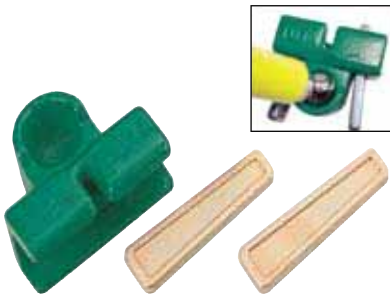

AE330030

UNIBODY CLAMP

- Capacity : 5 ton
- Single-way pull operation.
- When the damage is in the middle of car plate and it is not easy to fix by those clamps.
- This model of tool is using to fix this kind of problems.



AG010030A

6PCS AUTO REPAIR TOOL SET

CONTENTS :

- | | |
|-------------|---|
| AG010030A-2 | 1 PC Double End Hand Dolly. |
| AG010030A-3 | 1 PC Drip Moulding, Spoon. |
| AG010030A-1 | 1 PC Curved Dolly. |
| AG010030A-4 | 1 PC Toe Dolly. |
| M10110 | 1 PC Pick & Finish Hammer. |
| M10401B | 1 PC Light Shrinking Hammer (Flat Face) |



AE330027

MULTI HOLE PULL PLATES

- To lock the screws with plate on the car, in order to pull straight-line.



AE330031

DOUBLE CONNECTOR

- Capacity : 6 ton
- Use with 5/16" or 3/8" chains.
- This tool enables you to use two clamps side by side for more pull.

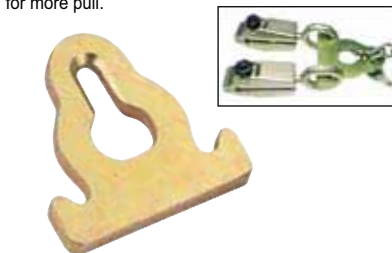

AG010033

TELESCOPING INSPECTION MIRROR

Size : 50 x 92mm



AE330028

DOOR POST PULLER

- Applicable chain : 5/16" , 3/8"
- Fixed on the car to pull side long-line.



AE330032

HANDY LINK

- Capacity : 6 ton
- For use as chain shorter, chain connector or double hooks.
- Use with 5/16" , 3/8" chains.

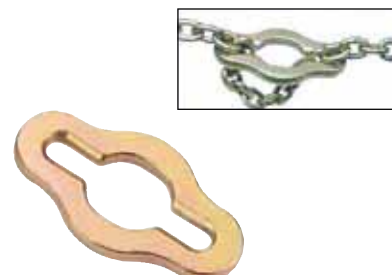

AG010034

MAGNETIC PICK-UP TOOL

Heavy duty pocket.

Capacity : 3.5 Lbs.

L : 580 mm.



AG010101

14" PUSH & FOLDABLE CROSS-HANDLE SOCKET WRENCH

- Mat Finish
- Socket Size : 17, 19, 21, 23 mm (11/16", 3/4", 13/16", 7/8")



AG010109

2PCS NUT SPLITTER SET

- Chrome Vanadium Steel
- SIZE : 1/2"-5/8" (12mm-16mm)
- 5/8"-7/8" (16mm-22mm)



AG010138

1/2" IMPACT DRIVER W/36MM 13BITS

- The new grip can keep your hands away from potential danger while striking.



AG010140

MULTI - DOLLY (WIDTH:37MM)

- Auto body repairing D.I.Y & sheet metal working.
- Student crafts working.
- Personal working studio.
- Made from carbon steel by hot forging & precision.
- Heat - treatment.



AG020019

4 TON HAND POWER PULLER

- Capacity : 4 TON (800lbs) All type with switch.
- Handle Metal Thickness : 5.0mm (Chrome Plated).
- Body Metal Thickness : 6.0mm (Chrome Plated).
- Double Gear & Double Pawl (Both in Durable Solid Steel).
- Cable : Dia. 6mm x 10 ft with 3 Hooks.



AN010009A

SUMP PLUG KEY (MM)

- Size : 15, 14, 13, 12, 11, 10, 17-14mm
- Length : 150mm



AN010012A

AUTOMATIC TRANSMISSION CLUTCH SPRING COMPRESSOR (IMPROVEMENT)

- For removing and installing the transmission rear clutch piston snap ring...
- Adjustable, for most models of American cars and light trucks.
- NW : 3.2 kgs GW : 3.4 kgs



AN010030A

WHEEL WEIGHT BALANCE PLIERS



AN010045

BALL JOINT SEPARATOR

- Placed between ball joint and steering knuckle and give a few sharp blows with a hammer.
- Forged and heat treated 5/16" Opening Length : 12".

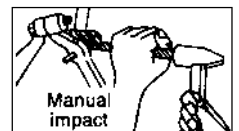

AN010048

UNIVERSAL STRUT SPRING COMPRESSOR

- This tool fits a wide range of struts without the inconvenience of special adapter shoes.
- Tool compresses springs of 4" to 8" OD with wire diameters of 7/16" to 11/16".
- Works both by hand or impact wrench.
- The jaws of the compressor are held in place by safety locking pins.
- Use most of spring compressor quickly and easily on the bench or on the vehicle.



AN010054A

3PCS COMPOSITE HOSE PINCH TOOL SET

- Special-radius jaws design will not damage internal hose lining.
- Lightweight, non-conductive, bright color 3 sizes for different application.



AN010064

OVERHEAD VALVE SPRING COMPRESSOR

- For use on a wide range of OHV, OHC and CVH engines not suitable for use on engines with deep seated valves.
- Allow valve springs and valve stem oil seals to be replaced with the cylinder head.
- Feature a reversible jaw/adaptor and automatic cam-action locking to a pre-determined setting.



AN010070

REAR DISC BRAKE CALIPER TOOL

- For rotating pistons back into the caliper to provide clearance for new pads.
 - Includes 5 adapters for use in both 2 and 4 wheel rear disc brake assemblies most of cars.
 - Tool may be used "ON" or "OFF" the car.
- A real time saver that makes this tough job easy helps prevent damage to the piston and boot.
- Contents use including:
Most HONDA, MAZDA, DODGE, MITSUBISHI, SUBARU, TOYOTA, FORD & GM etc.



AN010072

EXTERNAL & INTERNAL RESTORER FILES

- Restore tool for renewing damaged thread on any diameter bolt, stud, axle or shaft file both right and left hand threads.
- Design for in hide & narrow area usage.
- Description pitch sizes
- Metric file 0.80 , 1.00 , 1.25 , 1.50 , 1.75 , 2.00 , 3.00

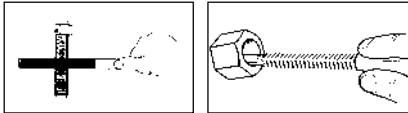

AN010072A/B/C

EXTERNAL THREAD RESTORING FILES

- Restore tool for renewing damaged thread on any diameter bolt, stud, axle or shaft file both right and left hand threads.



ITEM NO.	DESCRIPTION	PITCH SIZES
AN010072A	Metric file	0.75 1.00, 1.25, 1.50, 1.75, 2.00, 2.50, 3.0mm
AN010072B	SAE file	11, 12, 13, 14, 16, 18, 20, 24
AN010072C	SAE file	9, 10, 12, 16, 20, 27, 28, 32

AN010085A

SNAP IN TIRE VALVE INSTALLER

- Steel constructed tool with deep threaded head for positive sealing of all snap-in type passenger car tire valve stems.
- Rubber cover design to protect the rim.
- 3 position settled Patented.



AN010091A

INNER TIE ROD TOOL

- These tools are specially designed for the inner tie rods that are inaccessible to adjust.
- The long socket can be easily used with seven open-jaw drivers, size 1-3/16", 1-1/4", 1-5/16", 1-7/16" & 14mm, 17mm, 33.6mm, to most application.
- The inner tie rod can be easily removed and installed by slipping the long socket over tie rod end and connecting it to the open-jaw driver.



AN010092

MULTI-PURPOSE INNER TIE ROD TOOL

- The master tie rod tools easily replaces inner tie rod ends without removing the rack & pinion.
- Capacity : 33-42mm Patented.



AN010106A

EXHAUST AND TAILPIPE CUTTER

- Use tool to cut pipes 3/4" to 3" (19 to 76mm) in diameter.
- Fifteen blades effectively cut pipe so only 1/4 turn is needed for a complete cut.
- Patented, serviceable tool works in hard-to-reach areas.
- It will not cut double-wall pipes.
- Keep well oiled, and do not for use on stainless steel.



AN010111

UNIVERSAL SHOCK ABSORBER TOOL

- For removing & installing shock nuts.
- Two stem sockets to fit most all shock stems.
- The nut socket is double-ended to fit most shock nuts.

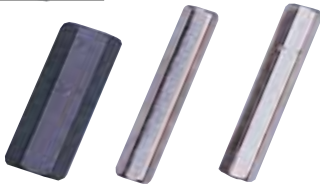
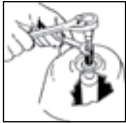

AN010160

8PCS MANUAL BRAKE GAUGE SET



- Designed for accurate measurement of how much brake lining is left without guess work.
- Most state agencies require that the users be notified of how much brake lining is left in order to suggest that the lining should be replaced.
- Technician must refer to the OEM manufacturer specifications to determine if the lining is worn below minimum specifications.
- Size including : RED - 2MM(0.0787") 3MM(0.1181")
YELLOW- 4MM(0.1575") 5MM(0.1969") 6MM(0.2363")
GREEN-8MM(0.3160") 10MM(0.3937") 12MM(0.4724)

AN040042

45° FLARING, DOUBLE FLARING & CUTTING TOOL SET

Includes heavy duty tube cutter, standard 45° flaring tool and double flaring adapters set in custom carrying case.

Heavy duty tube cutter for 1/8" to 1-1/8" tubing; standard 45° flaring tool flares 7 sizes : 3/16", 1/4", 5/16", 3/8", 7/16", 1/2" and 5/8" O.D. tubing; five double flaring adapters cover 3/16", 1/4", 5/16", 3/8" and 1/2" O.D.



AN040043

45° FLARING, DOUBLE FLARING & CUTTING TOOL SET

Includes heavy duty tube cutter, standard 45° flaring tool and double flaring adapters set in custom carrying case.

Metric flaring, double flaring & cutting tool set flares seven metric sizes: 4mm, 6mm, 8mm, 10mm, 12mm, 15mm and 16mm O.D. tubing. Five double flaring adapters cover 4.75mm, 5mm, 6mm, 8mm and 10mm tubing.



AN040056

BPW TRUCK SOCKET TOOL (REAR WHEEL)

- The rear axles cover extractor socket
- Size : 120mm, octagon.
- Applicable : BPW-16T



JONNESWAY Malaysia, Singapore & Brunei distributors training course in R&D and logistic center 2009 at Taichung, Taiwan.



JONNESWAY Malaysia Distributor holding the 2009 National Institute of Occupational Safety & Health Seminar at Johor Bahru.

